

AIR HANDLING UNITS CCM Range

Air flows 0.3 to 9 m³/s

Very compact design

Short delivery option: CCM Flash

Casing design to 'EN 1886' standards

Class: B - 2 - T3 - TB2 - F9

Eurovent certified

Hospital Specification options to CO4 and HTM2025



Introduction

Ozonair Hydronic's air handling units are synonymous with good design and quality and is the result of 40 years of progressive development.

Attractive design

The CCM unit has an attractively designed outside casing based on the self supporting panel concept. The outer skin is painted in 2 colours, green (RAL5018) and grey (RAL 7024). An especially textured finish enhances the appearance.

Accessibility

Every section requiring access is fitted either with a quick opening panel or hinged door.

Flat pack

The CCM unit can be supplied either fully assembled (modular sections), or in 'flat pack' for site assembly by our Site Service Team..

Stability

The CCM unit is supported on uniquely designed feet, and has good mechanical rigidity allowing easy site handling and installation. The 90mm gap under the unit allows good air movement and assists in the fitting of water traps from the drain sections.

Support

This technical catalogue enables initial selections to be made, ie. size, capacity, overall dimensions, weights etc. To quickly obtain a detailed and accurate computer selection, contact our sales office.

Index

	Page
<i>Introduction and index</i>	2
<i>General information</i>	3
<i>Quick selection</i>	4
<i>Technical information</i>	5 - 7
<i>Sound levels</i>	8
<i>Energy recovery systems</i>	9
<i>Unit length calculations</i>	10
<i>Component lengths</i>	11 - 15
<i>Vertical CCM units - from CCM20 to CCM170</i>	16 - 17
<i>Vertical AHU arrangements</i>	18
<i>Dimensions - Air intake & Fan discharge</i>	19
<i>Dimensions - Connections</i>	20 - 22
<i>External air handling units</i>	23
<i>Typical AHU arrangements</i>	24 - 25
<i>Weights (casings and motors)</i>	26
<i>Weights (all other components)</i>	27

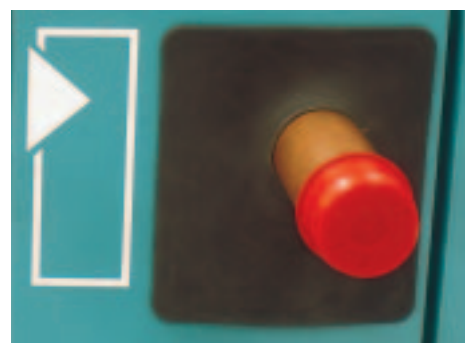
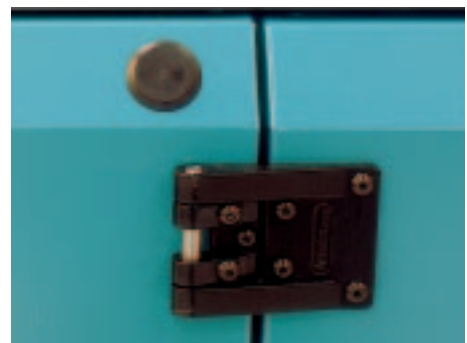
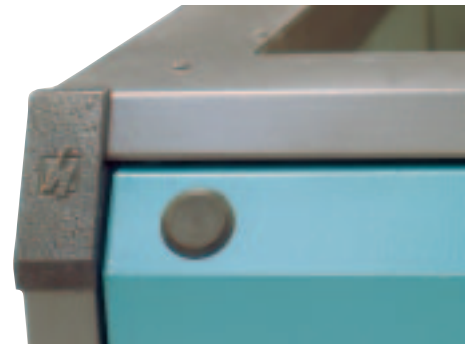

CCM range

General information

Unique design

The numerous components are designed to give a smooth and attractive appearance. The filters, for example, are on slides with front clamping of the filter bank. Air tightness efficiencies of up to 95% OPA (EU9) are achieved. Pressure tapping points are provided.

Compact

By optimising the performance of each section of the CCM unit, the overall length and size can be kept to a minimum.

Clean (Inside and outside)

The smooth standard 50mm thick double skin design of the CCM unit not only provides a neat external appearance, but also provides a very smooth inside finish keeping internal air resistance low.

Air Velocity

Eliminators with face velocities of up to 4.5 m/s are available together with an internal drain tray correctly shaped to ensure good drainage is provided. This forms part of the attention to detail throughout the CCM range of units.

Functional

With a very large choice of components (mixing devices, filters, coils etc) the CCM unit also benefits from a wide selection of fan sizes and speeds assuring good external static pressure development, low absorbed fan power and low sound levels.



Casing construction

- Double skinned panels, 50mm thick
 - The outer skin is painted in 2 colours with textured finish.
 - The inner skin is smooth and galvanised without painting.
 - Optional: stainless steel or alternative colour finishes.
 - The insulation is mineral wool 40 kg/m³ (M0).
 - Optional: Polystyrene or Polyurethane insulation.
- Based on EN 1886 standards, the following apply:
 - Casing air leakage is class B
 - Casing strength is class 2 or class 2 A depending upon fan selection
 - Casing thermal insulation is class T3
 - Thermal bridges: TB2
 - Filter assembly leakage: F9

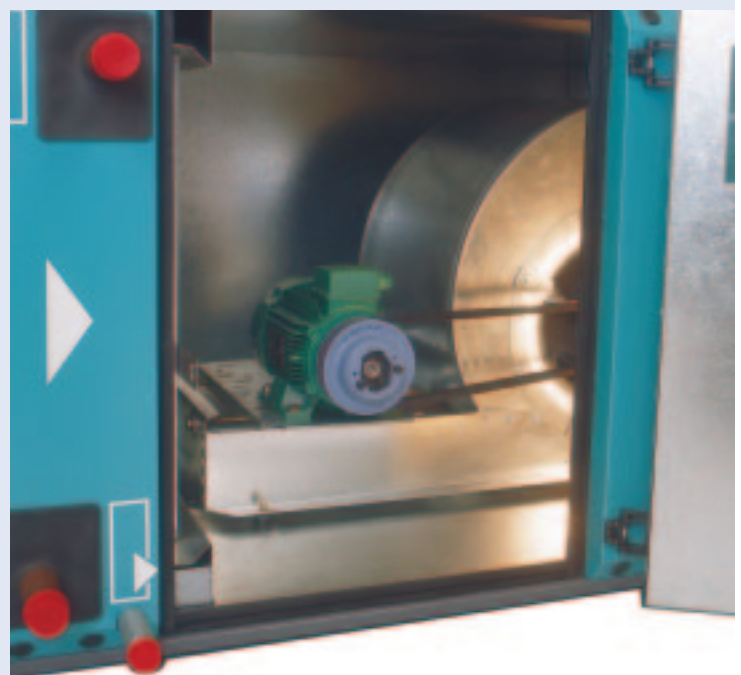

Quick selection

Each size is represented by a horizontal bar with various air velocities based on normal coil areas. Appropriate air velocity is, above all, determined by the sensible heat / total heat ratio. Selected air velocity will generally fall between 2 m/s and 4.5 m/s.

Cooling applications

Horizontal AHU's

- Without eliminator up to 2.8 m/s
- With steel eliminator M0 up to 3.25 m/s
- With high velocity eliminator M1 up to 4.5 m/s (check fan curves)

Vertical AHU's* (upwards airflows except CCM 210-255)

- Without eliminator up to 3.0 m/s
- Eliminators are not available

Heating applications

- All AHU's up to 4.5 m/s (check fan curves)

* Vertical arrangements are not available in CCM 210, 255 and 315 sizes

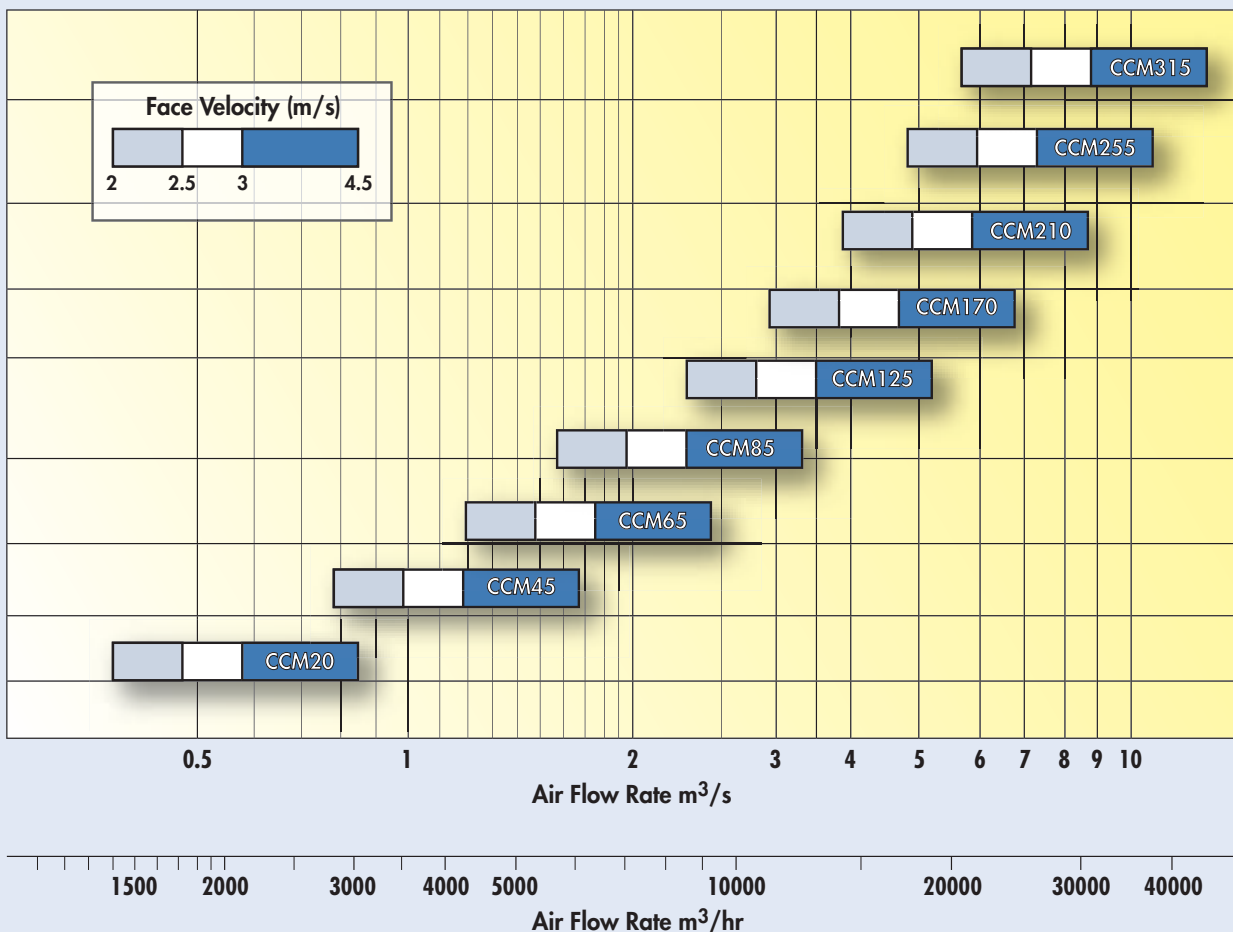
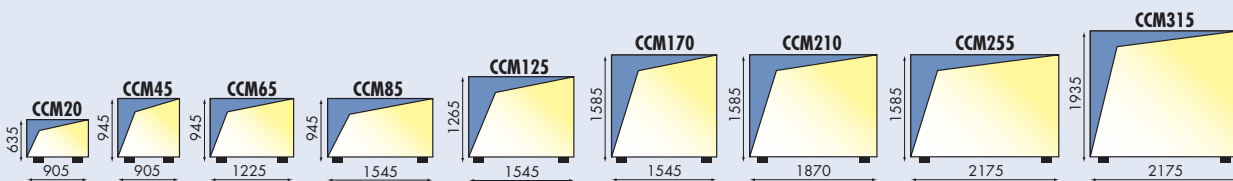

Air intake and mixing box

Various arrangements are available:

- Intake or anti-frost damper
- 2 way mixing section
- Single air intake section
- 3 way mixing section

Each air intake section includes one connection with provision for a flexible connection type M0.

Dampers mounted inside the unit are of the opposed blade type and can be,

- either CDO aerodynamic profile type
- or CDE low leakage construction

They are fitted with a nylon seal.

Dampers mounted outside the unit have blades mounted in ball bearings.

Dampers are provided with an external shaft (for manual operation or motorised drive).

Filters

Various types of filters and mountings are available, depending upon specifications and required efficiency.

• PREFILTER

- 2 versions with slide rails for side withdrawal if prefilter is the full cross section of AHU
 - G2: Flat filters made of galvanised steel wire mesh, efficiency 65% GRAVIMETRIC (EU2), fire classification M0
 - G4: Flat filters, with pleated synthetic media, efficiency 95% GRAVIMETRIC (EU4), fire classification M1
- 2 versions of same type of filters but of universal size, mounted in rails with clamping device (side withdrawal).
- 1 version with front removal, through access casing.
 - Prefilter section with flat filters mounted together with bag filters.
 For this option, frames and access for front removal will be necessary.

• MAIN FILTER

Normally, the main filtration is done with opacimetric filters, long bag filters (OP), short bag filters (OC) or rigid bag filters (OD)

A unique system of support rails has been designed, which allow side withdrawal of filters whilst maintaining air tightness on the filter bank.

For frame mounted filters it is necessary to use an access section.

Filter efficiencies are : F6: 65% OPA (EU6) F7: 85% OPA (EU7) F8/F9: 95% OPA (EU9)

All filter fire classified : M3

• FINAL FILTERS

- Generally located, downstream of the fan assembly this level of filtration is achieved by ABSOLUTE FILTERS : Media is of fibreglass material, of rigid cartridge type and disposable, classification M1
Various efficiencies are available. The most generally used are: H10 : 95 % DOP (EU10) or H13 : 99.99 % DOP (EU 13)
- Front removal through access casing.
When using this type of filter, high efficiency prefiltration section and balancing damper are highly advisable, as well as selection of a backward curved fan.
Pressure tappings are provided on any filter type. Manometers with inclined tubes are available on request.

FILTER CLASS		Gravimetric efficiency %		Opacimetric efficiency %		% DOP	
G1	(EU 1)	$A_m \leq 65$					
G2	(EU 2)	$65 \leq$	$A_m \leq 80$				
G3	(EU 3)	$80 \leq$	$A_m \leq 90$				
G4	(EU 4)	$90 \leq$	A_m				
F5	(EU 5)			$40 \leq$	$E_m < 60$		
F6	(EU 6)			$60 \leq$	$E_m < 80$		
F7	(EU 7)			$80 \leq$	$E_m < 90$		
F8	(EU 8)			$90 \leq$	$E_m < 95$		
F9	(EU 9)			$95 \leq$	E_m		
H10	(EU 10)					95	$\leq \% < 99.9$
H11	(EU 11)					99.9	$\leq \eta \% < 99.97$
H12	(EU 12)					99.97	$\leq \eta \% < 99.99$
H13	(EU 13)					99.99	$\leq \eta \% < 99.999$
H14	(EU 14)					99.999	$\leq \eta \%$

• Heating and cooling coils 1/2" Ø tube (5/8" Ø tube optional)

The Ozonair Hydronic coils are usually manufactured with copper tubes and aluminium fins with copper headers. Depending upon requirements,, fin spaces can be 2.1mm, 2.5mm or 3.2mm, and coils equipped with 1, 2, 3, 4, 6 or 8 rows. All coils included in CCM AHU's are easily removable and mounted on slide rails.

A shaped drain tray under the cooling coil ensures good drainage.

Two different models of droplet eliminators can be mounted after cooling coil modules when air velocities are above 2.8 m/s.

- One is suitable up to 3.5 m/s (metallic wire mesh) M0
- The other is suitable up to 4.5 m/s (high velocity eliminator) M1

Coils can either be of hot or cold water type (or glycol water) or with direct expansion, (DX).

Alternative steel/aluminium, copper/copper, copper/copper electrotinned, copper/polyurethane coated alu, copper-nickel and stainless steel tube are available.

Testing pressure: 20 bar for an operating pressure of 8 bar maximum.

• Electric heater batteries

Electric heater batteries consist of a sheet steel galvanized framework to which are fixed the elements, with a box protecting the connection terminals. The heating elements are of straight stainless steel tubes with spiral stainless steel fins.

As standard, the electric heater battery is supplied unwired, with the number of elements in multiples of 3 for connection to 230 V or 400 V - 3 phases supply.

Where possible, especially for high capacity applications, electric heater batteries should be located on fan discharge. Thermal protection M0 should be provided before or after the battery if necessary.

Electric heater batteries are supplied with a manual reset safety thermostat (110°C).

If the AHU is used with a variable air volume system, please check that the air velocity over the electrical elements is not lower than 2 m/s. Fan and electric heater battery must be turned ON and OFF together with temporising relay.

• Humidification systems

Evaporating humidifier

The wet deck type humidifier is equipped with an evaporating system including a drain pan, a water-pump (except CCM 20 and CCM 45, direct connection water) and a spray header.

In this cell humidification system, evaporating pads are kept constantly wet through the circulating water flow .

This ensures an optimum exchange, where the air absorbs progressively evaporated on the surface of the medium.

Three humidification levels can be obtained : 60% - 80% - 90%.

Each humidifier has a maximum humidification capacity, which is represented by the maximum water weight which can be evaporated for each volume of 1 kg of dry air.

This maximum capacity, is :

- 6g/kg of dry air for the HR 60
- 8g/kg of dry air for the HR 80
- 8 to 10g/kg of dry air for the HR 90

Media is of fibre glass material and, therefore non-flammable type class M1. It offers excellent solidity and anti-corrosion characteristics.

Each module is equipped with a stainless steel frame.

The water quantity required and used by such type of humidifier is very low. It is the evaporated water quantity plus the collection pan deconcentration water,

Optional, this section can be equipped with an hinged door with porthole and inside lighting (24 V) wired to external switch.

• Fan assembly

Each AHU can be supplied with 2 possible selections of backward and forward curved fans. Choice is made depending on efficiency, absorbed power and noise level.



CCM	Forward Curved		Backward Curved	
	Nominal	Maximum	Nominal	Maximum
20	A 200	A 225	R 200	R 225
45	A 250	A 280	R 250	R 280
65	A 315	A 355	R 315	R 355
85	A 355	A 400	R 355	R 400
125	A 450	A 500	R 450	R 500
170	A 500	A 560	R 500	R 560
210	A 560	A 630	R 560	R 630
255	A 630	A 710	R 630	R 710
315	A 710	A 800	R 710	R 800

• Fan assembly (continued)

Consists of a double inlet centrifugal forward or backward curved fan depending upon specification plus motor and drive mounted on a steel chassis.

The assembly is isolated from casing by anti-vibration pads and flexible connection class M0 as standard.

Transmission is by means of V-belts and iron or aluminium pulleys, depending on capacity. Optional V-belt guard enabling speed measurement can be provided.

Motor is mounted on slide rails to allow adjustment of belt tension. Motor class can vary to meet requirements (min class. F), Various ventilation systems can be combined : variable air flow - variable fan speed - 2-speed, etc...

Fan type can be selected in order to comply with the specification. Backward curved fan can be equipped with manual or automatic inlet guide vanes(except for CCM 20 and CCM 45).

Optional, a plug fan with direct drive and variable frequency drive.

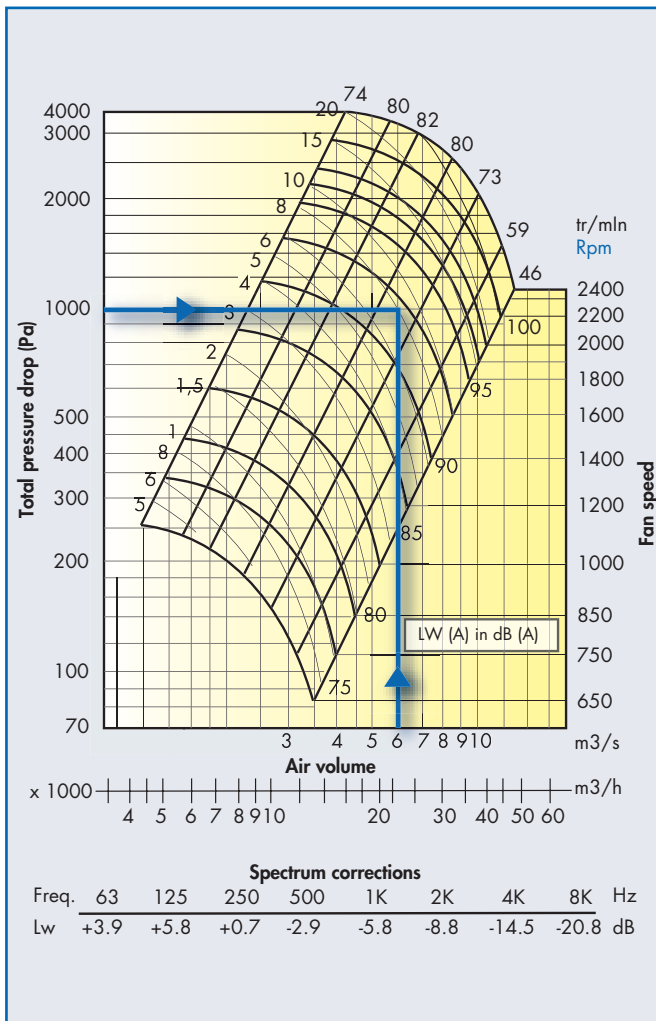

• Attenuators

The attenuators can be mounted on both sides of fan (air inlet and air outlet). They include splitters of various sizes. Each splitter is 200 mm thick and air ways are about 100 mm wide.

The splitters are made of mineral wool, class M0, with a glass fibre reinforced top layer to prevent fibres from breaking away.

Frequency (Hz)	63	125	250	500	1K	2K	4K	8K
600 attenuator	- 4	- 11	- 15	- 20	- 24	- 26	-22	-15
900 attenuator	- 5	- 12	- 17	- 25	30	- 32	-28	-20
1200 attenuator	- 6	- 13	- 20	- 30	- 36	- 38	-34	-25
1500 attenuator	- 7	- 15	- 24	- 35	- 42	- 45	-40	-30

• Sound levels

SOUND LEVEL EXAMPLE

Plan view

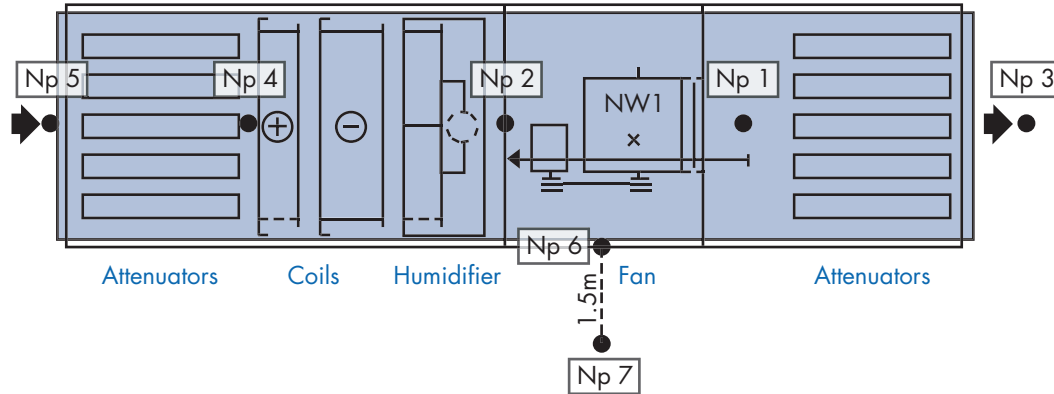

Example : CCM 170 with backward curved fan size 560:

Q = 6 m³/s Total pressure = 1000 Pa N = 1570 Rpm

From the fan diagram : Overall sound power level of fan assembly : 90 dBA and the fan sound spectrum in dB :

Frequency (Hz)	63	125	250	500	1K	2K	4K	8K
Nw (dB)	90	90	90	90	90	90	90	90
	+4	+6	+1	-3	-6	-9	-14	-21
	94	96	91	87	84	81	76	69

We can consider that the soundpower is equally divided between intake and discharge sides

$$90 \text{ dBA} \longrightarrow \begin{cases} 87 \text{ dBA on discharge side} \\ 87 \text{ dBA on intake side.} \end{cases}$$

Furthermore, the sound pressure level at 1m can be calculated by subtracting 7 dB from the sound power level, on intake as well as on discharge side.. So to obtain the following spectrum at 1 and 2:

Frequency (Hz)	63	125	250	500	1K	2K	4K	8K
NP1 & NP2 (dB)	94	96	91	87	84	81	76	69
	-3	-3	-3	-3	-3	-3	-3	-3
	-7	-7	-7	-7	-7	-7	-7	-7
	84	86	81	77	74	71	66	59

If the unit has 1200mm long attenuators, the spectrum will be modified as follows:

Frequency (Hz)	63	125	250	500	1K	2K	4K	8K
NP3 (dB)	84	86	81	77	74	71	66	59
	-6	-13	-20	-30	-36	-38	-34	-25
	78	73	61	47	38	33	32	24

This spectrum squares to an average overall sound pressure level of 60 dBA Np3 = 60 dBA.

On intake side, the sound pressure attenuation achieved by components (coils and humidifier) should also be taken in account, giving : Np4 = Np2 - 5 dBA

And the resulting sound pressure level Np5 = Np3 - 5dBA. Np5 = 55 dBA.

In a plant room, attenuation through sandwich-type panel of CCM unit is approximately 20 dB.

Therefore, Np6 = 80 - 20 = 60 dBA and Np7 at 1.50m distance from casing = 54 dBA (at 3m distance from casing, Np8 = 54 - 6 = 48 dBA).

• **Energy recovery systems (Eurovent Certification not available)**

Various standard systems are available to recover the major part of the energy available in leaving air :

- 3-way mixing section
- Water / glycol run around coils
- Plate Recuperators Horizontal or Vertical, with or without by-pass
- Heat pipe exchanger Horizontal or Vertical, with or without by-pass on exchanger or 3 way by-pass section
- Thermal wheel (Please contact our sales department for more information)

Plate recuperators

Always monobloc, it can be provided with a prefilter on fresh air and return air. An antifrost electric heater battery can be installed in front of recuperator. Access panels are an option.

• **Heat pipe**

Always monobloc, it can be provided with a prefilter on fresh air.
A discharge section must be selected depending on AHU configuration.
A choice between 4 and 6 rows available.

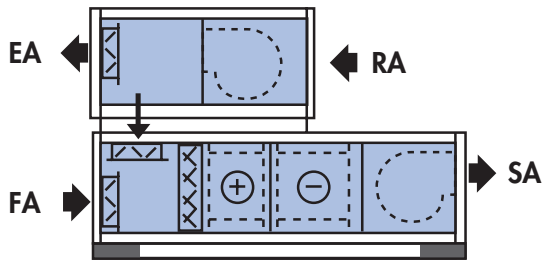

Double stacked unit with 3 way mixing box

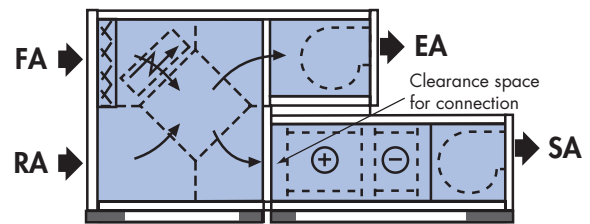

Air handling unit with plate recuperator

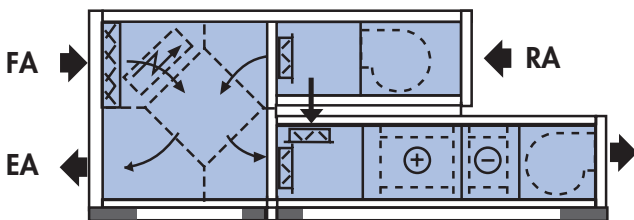

Air handling unit with plate recuperator and 3 way by-pass section

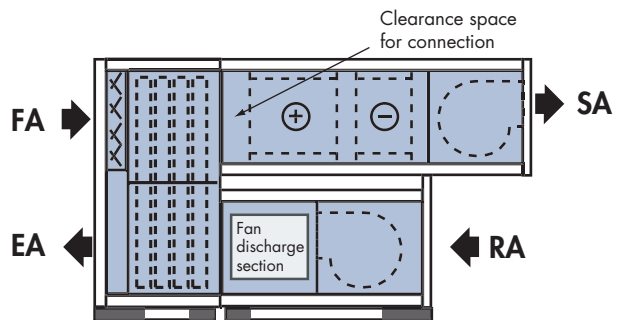

Unit with heat pipe without by-pass

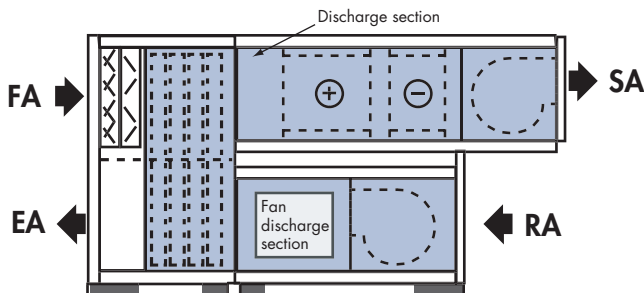

Unit with heat pipe and by-pass

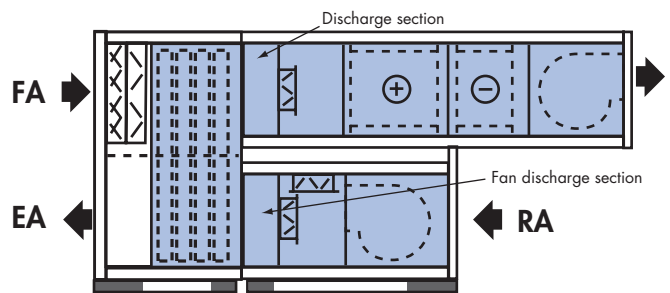

Air handling unit with heat pipe, by-pass and 3 way mixing section

Airflow Codes:

FA - Fresh Air SA- Supply Air RA- Return Air EA- Exhaust Air

Generally, the unit is divided into the least possible number of sections, whose dimensions can still permit road transportation. On request, the unit can be divided into a larger number of sections to meet site erection requirements (extra cost).

Total unit length determination procedure

To obtain theoretical total unit length add component dimensions given on pages 11 to 15.

To obtain the actual total unit length add 80mm of manufacturing constant and twice 32 mm for end frames and for any number of sections in which the unit is to be manufactured.

Example: CCM65 - Arrangement L6 (see page 15)

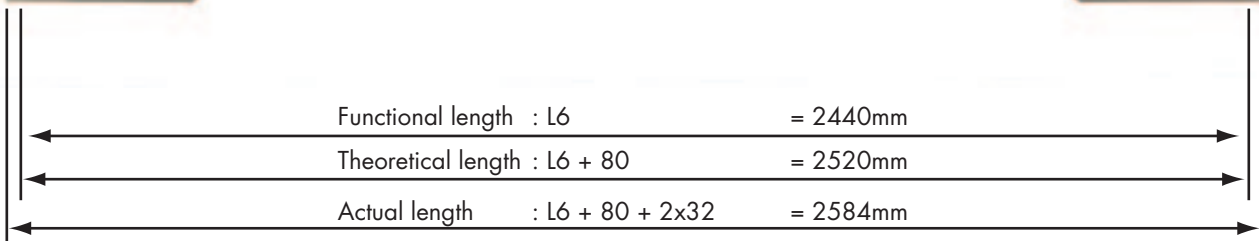

Section Code	Description	Section length
110	Mixing Section	320 mm
20	Filter EU4 95% Gravi.	120 mm
231	Short bag filter 85% EU7	440 mm
404	Heating coil 1 to 4 rows	200 mm
444	Cooling coil 3 to 4 rows	280 mm
604	Fan section (max size)	1080 mm

The maximum length of a single unit is 2680 mm.

As the functional length of 2440 mm is lower, the unit would be supplied as standard in 1 part (monobloc).

The theoretical length is 2520 mm, to obtain the actual length, add $2 \times 32 = 2584$ mm.

CCM range

Component lengths

Section Type	Code	Symbol	Description	CCM									
				20	45	65	85	125	170	210	255	315	
Intake	0800		Fresh air intake hood for air intake or lateral mixing section	mm L =	410	590	590	590	850	1050	1050	1050	1250
	0820		Fresh air intake hood for standard mixing section	L =	160	300	300	300	500	600	600	600	600
	1000 1001		Anti frost damper Internal fire or balancing damper	L =	185	185	185	185	185	185	185	185	185
Mixing	1100 to 1170		2-dampers mixing section or single air intake section.		200	320	320	320	440	560	560	560	720
	1550 to 1590		2 dampers mixing section with lateral side damper		320	320	440	560	560	560	680	800	1080
	1101 to 1171		2 dampers mixing section Single air intake section (Ext. damper)		240	400	400	400	560	720	720	720	720
	1511 to 1591		2 dampers mixing section with lateral side damper (Ext. damper)		440	440	600	760	760	760	920	920	1080
	1200 1260		3-way mixing section		480	720	720	720	960	1200	1200	1200	1480
	1210 1220 1230		Diagonal 3-way mixing section		680	680	920	1160	1160	1160	1400	1600	2000
	1300 1320		Double deck 3 dampers mixing section		200	320	320	320	440	560	560	560	720
			The same with upstream discharge section		280	480	480	480	680	880	880	880	720
				A1 =	1180	1800	1800	1800	2440	3080	3080	3080	3780
	1310 1330		Side by side 3-way mixing section		320	320	440	560	560	560	680	800	1080
		The same with upstream discharge section		480	480	680	880	880	880	1040	1200	1080	
			B1 =	1820	1820	2460	3100	3100	3100	3750	4360	4435	









Note: The shaded lengths are not used for AHU length determination.

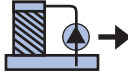
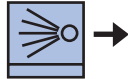

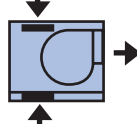
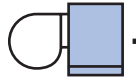
Section Type	Code	Symbol	Description	CCM									
				20	45	65	85	125	170	210	255	315	
Filters	2000 2020 2040 2050		All types of prefilter - full section or universal dimensions L < 50mm	120	120	120	120	120	120	120	120	120	120
	2030		Full section - Dual prefilters L = 20 + 50mm	120	120	120	120	120	120	120	120	120	120
	2200		Pleated type filters L max = 95mm	200	200	200	200	200	200	200	200	200	200
	2310 2312		Short bag filters L max = 380mm	440	440	440	440	440	440	440	440	440	440
	2210		Long bag filters L max = 635mm	720	720	720	720	720	720	720	720	720	720
	2510		Absolute filters L max = 292mm	320	320	320	320	320	320	320	320	320	320
	2520		Activated carbon filter L max = 410mm	440	440	440	440	440	440	440	440	440	440
	2700		Sand filters L =	75	75	75	75	75	75	75	75	75	75
Access	2100 2101		Access section	560	560	560	560	560	560	560	560	560	560
Heating	4020 4040 4060 4080		Heater battery 12.7mm / 1/2" tubes	1 or 2 rows 3 or 4 rows 6 rows 8 rows	200 240 280	200 240 280	200 240 280	200 240 280	200 240 280	200 240 280	200 240 280	200 240 280	280
	4210		Electric heater battery - 1 row	P max kW	15.6 240	31.2 240	48 240	66 240	99 240	132 240	168 240	192 240	240
	4220		Electric heater battery - 2 rows	P max kW	31.2 320	62.4 320	96 320	132 320	198 320	264 320	336 320	384 320	480
	4440 4460 4480		Cooling coil with metallic eliminator	3 or 4 rows 6 rows 8 rows	280 320 360	280 320 360	280 320 360	280 320 360	280 320 360	280 320 360	280 320 360	280 320 360	360
4441 4461 4481		Cooling coil with high velocity eliminator	3 or 4 rows 6 rows 8 rows	320 360 400	320 360 400	320 360 400	320 360 400	320 360 400	320 360 400	320 360 400	320 360 400	480	

* For CCM315, eliminator with blades

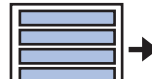
CCM range

Component lengths

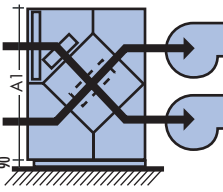
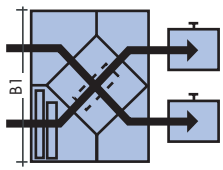
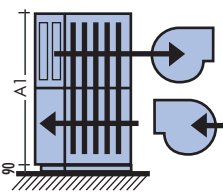
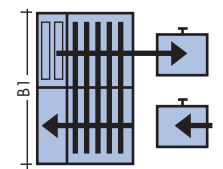
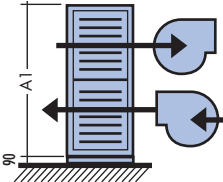
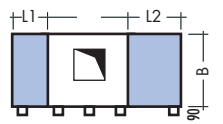
Section Type	Code	Symbol	Description	CCM									
				20	45	65	85	125	170	210	255	315	
Humidification	5100 5200 5300		h: 60%	440	440	440	440	440	440	440	440	440	440
			h: 80%	520	520	520	520	520	520	520	520	520	520
			h: 90%	640	640	640	640	640	640	640	640	640	640
	5810 5820		without access	560	560	560	560	560	560	560	560	560	560
with access			1280	1280	1280	1280	1280	1280	1280	1280	1280	1280	
Fan section	6000 6100 6200 6300		Forward or Backward curved fan	Fan Type	200	250	315	355	450	500	560	630	710
				Motor kW	1.8	3	5.5	5.5	11	15	15	18.5	30
				Motor Type	90L	100L	132S	132S	160M	160L	160L	180L	200
	6040 6340 6070 6170		Nominal size		720	840	1000	1080	1320	1400	1520	1680	1920
			Forward or Backward curved fan	Fan Type	225	280	355	400	500	560	630	710	800
				Motor kW	2.2	4	5.5	7.5	15	15	18.5	22	37
		Maximum size		760	920	1080	1160	1400	1520	1680	1840	2120	
Expansion	2410		Expansion box without access		320	320	400	480	480	480	560	560	560
	2100 2101		Expansion box with access		560	560	560	560	560	560	560	560	560
Air discharge	0830		Discharge hood	L =	250	300	360	400	490	550	720	790	800
	6700 6710		Direct discharge plenum without grille		200	320	320	320	440	560	560	560	720
	6701 6711 6741		Direct discharge plenum with double deflection grille		200	400	400	400	680	880	880	880	
Attenuators	6910 6920 6930 6940		Inlet sound attenuators with 200mm thick splitters	length = 600	760	760	760	760	760	760	760	760	760
				length = 900	1040	1040	1040	1040	1040	1040	1040	1040	1040
				length = 1200	1360	1360	1360	1360	1360	1360	1360	1360	1360
				length = 1500	1640	1640	1640	1640	1640	1640	1640	1640	1640
	6911 6921 6931 6941		Outlet sound attenuators with 200mm thick splitters	length = 600	1000	1000	1080	1160	1160	1160	1240	1320	1320
				length = 900	1320	1320	1400	1480	1480	1480	1560	1640	1640
				length = 1200	1600	1600	1680	1760	1760	1760	1840	1920	1920
				length = 1500	1920	1920	2000	2080	2080	2080	2160	2240	2240

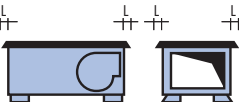
Section Type	Code	Symbol	Description	CCM										
				20	45	65	85	125	170	210	255	315		
Heat recovery	7000		Vertical plate heat recuperator with filter casing and defrost heater optional	without by-pass	560	840	840	1000	1200	1560	1560	1560	1960	
	7010			with by-pass	560	1000	1000	1000	1560	1640	1640	1640	2320	
	A1 =			1180	1800	1800	1800	2440	3080	3080	3080	3780		
	7100		Horizontal plate heat recuperator with filter casing and defrost heater optional	without by-pass	840	840	1200	1560	1560	1640				
	7110			with by-pass	1200	1200	1920	2280	2280	2280				
	B1 =			1820	1820	2460	3100	3100	3100					
	8000		Vertical heat pipe exchanger with filter casing 6 rows maximum	without by-pass	600	600	600	600	600	600	600	600	600	
	8010			with by-pass	760	760	760	760	760	760	760	760	760	
	A1 =			1180	1800	1800	1800	2440	3080	3080	3080	3780		
	8100		Horizontal heat pipe exchanger with filter casing 6 rows maximum	without by-pass	600	600	600	600	600	600	600	600	600	
	8110			with by-pass	760	760	760	760	760	760	760	760	760	
	B1 =			1820	1820	2460	3100	3100	3100	3750	4360	4360		
	8200		Thermal wheel for double deck units		400	400	400	400	400	400	400	400		
					A1 =	1180	1800	1800	1800	2440	3080	3080	3080	
	8500		External control box	L1 =	355	355	355	355	355	355	355	355	355	
8501	L2 =			730	730	730	730	730	730	730	730	730		
9000		Flexible connections		70	70	70	70	70	70	70	70	70		
9100		Anti frost probe drawer		80	80	80	80	80	80	80	80	80		
9200		Roof overhang		L =	70	70	70	70	70	70	70	70		

CCM range

Component lengths

Section Type	Code	Symbol	Description	CCM								
				20	45	65	85	125	170	210	255	315
Discharge	2120		Discharge section for double deck unit	320	400	520	560	680	760	880	960	1040
	65		Empty section. Minimum length	160	160	160	160	160	160	160	160	160

Preselection of common arrangements

Code	Arrangements	CCM										
		20	45	65	85	125	170	210	255	315		
L1		Actual length	L1 = mm	984	1104	1264	1344	1584	1664	1784	1944	2184
		Weight	P1 = Kg	99	132	179	220	311	371	471	580	700
L2		L2 = mm	L2 = mm	1504	1624	1784	1864	2104	2184	2304	2464	2744
		P2 = Kg	P2 = Kg	186	265	345	436	593	740	887	1046	1325
L3		L3 = mm	L3 = mm	1304	1424	1584	1664	1904	1984	2104	2264	2464
		P3 = Kg	P3 = Kg	157	220	291	321	510	629	754	907	1130
L4		L4 = mm	L4 = mm	2224	2344	2504	2584	2904	2984	3104	3264	3624
		P4 = Kg	P4 = Kg	234	319	414	534	784	938	1125	1323	1655
L5		L5 = mm	L5 = mm	1704	1944	2101	2184	2544	2744	2864	3024	3544
		P5 = Kg	P5 = Kg	212	307	396	500	704	874	1142	1341	1670
L6		L6 = mm	L6 = mm	2424	2664	2824	2984	3344	3544	3664	3824	4344
		P6 = Kg	P6 = Kg	259	361	470	644	877	1067	1297	1524	1880
L7		L7 = mm	L7 = mm	3504	3984	4304	4464	5264	5664	5824	6144	7184
		P7 = Kg	P7 = Kg	368	521	682	858	1243	1513	1918	2162	2825
L8		L8 = mm	L8 = mm	3784	4024	4184	4264	4624	4824	4944	5104	5704
		P8 = Kg	P8 = Kg	365	489	623	786	1035	1248	1510	1790	2285

EU4: Prefilter 95% AG
2R: 2 row heating coil

EU7: Long bag filter 85% AO
δR: 6 row cooling coil

EU9: Long bag filter 95% AO
Nominal fan size - 300 Pa external

Vertical CCM units - from CCM20 to CCM170

All the arrangements of vertical or 'L' shaped units are available. See length determination below.
 Only the prefilter, which is not included in the general casing, is an additional section of 115mm.
 Discharge plenum is included in the general casing. For vertical AHU, cooling coil cannot exceed 6 rows.



- Maximum face velocity on cooling coil: 3 m/s.
 Droplet eliminator is not available for vertical units

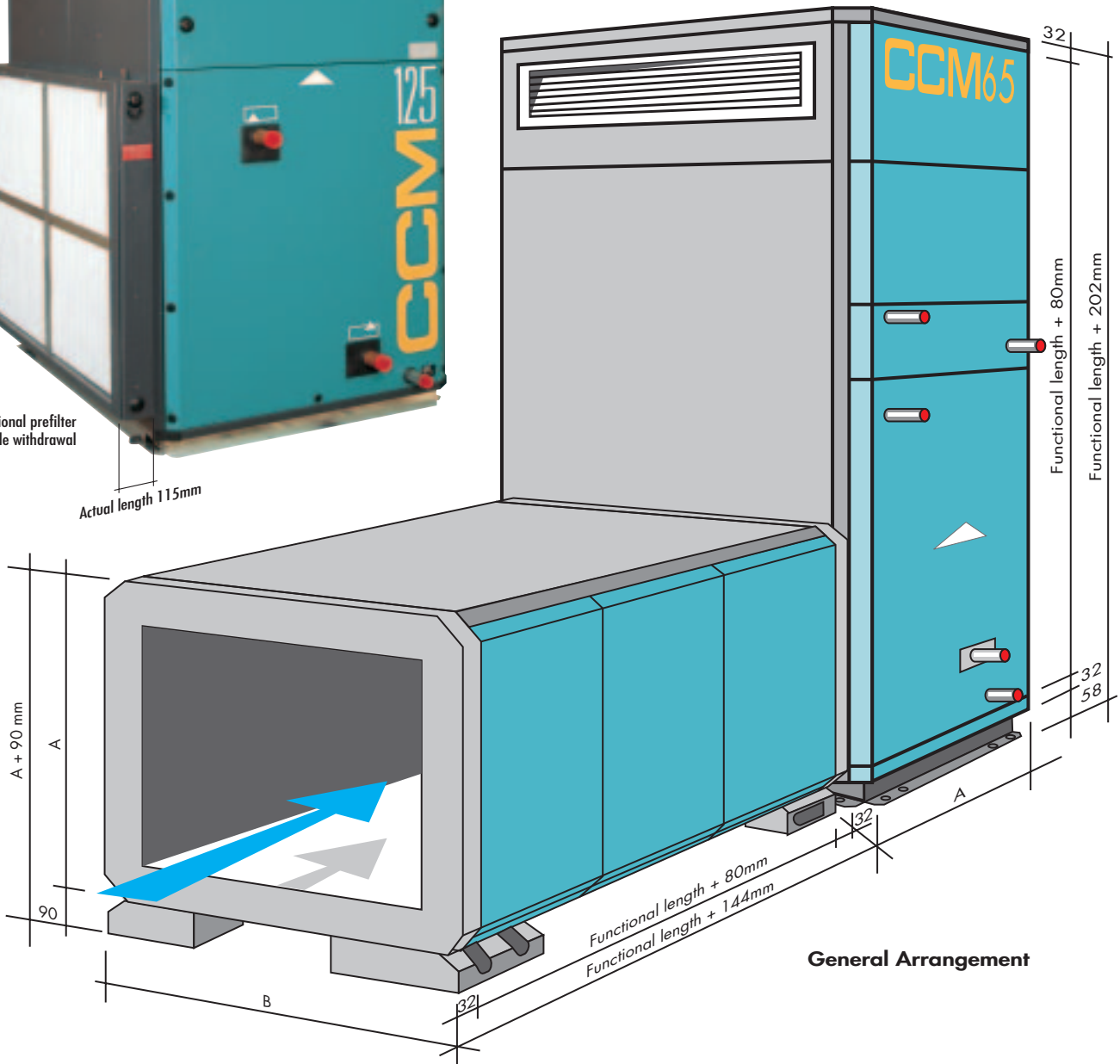

CCM range

Vertical CCM units - from CCM20 to CCM170

Vertical CCM sizes

Find in the table below, the height of the cooling section depending on air flow entering direction and heater battery location. Find the AHU height adding the different functional lengths as for a horizontal AHU.

Section lengths

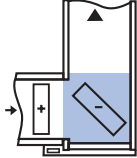
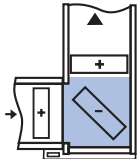
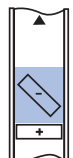
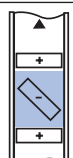
Section Type	Code	Symbol	Description	CCM					
				20	45	65	85	125	315
Cooling	4446		Horizontal air intake with duct or fan on discharge	470	760	760	760	1120	1400
	4447		Horizontal air intake with coil or filter on discharge	560	840	840	840	1160	1400
	4448		Vertical air intake with duct or fan on discharge	600	920	920	920	1320	1680
	4449		Vertical air intake with coil or filter on discharge	680	1000	1000	1000	1360	1680

Vertical AHU is on a chassis of 58mm, the actual length correspond to the functional length + 80 + (2 X 32) + 58 mm.

Example

For vertical arrangement CCM65:

Prefilter	120 mm
2 row heating coil	200 mm
6 row cooling coil	920 mm
Nominal fan	1000 mm
Functional length	2240 mm
Theoretical length	$2240 + 80 = 2320$ mm
Actual length	$2320 + 32 + 32 + 58 = 2442$ mm

- Vertical arrangements are not available in CCM210, 255 & 315 sizes

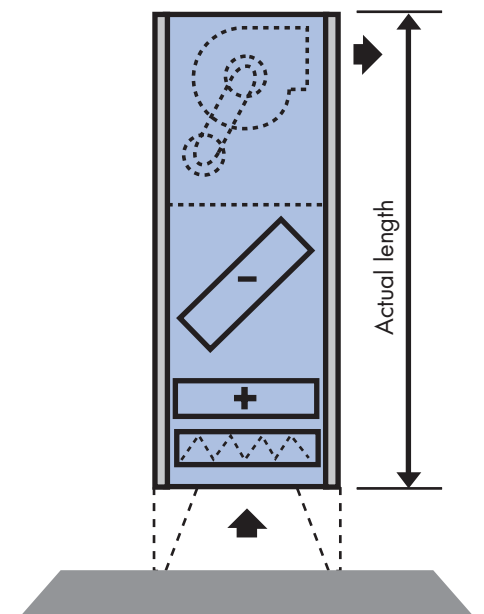

HVA Horizontal air intake

Left hand side access

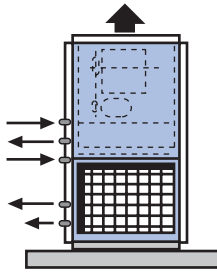

Right hand side access

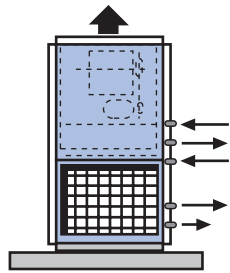

Rising vertical air flow

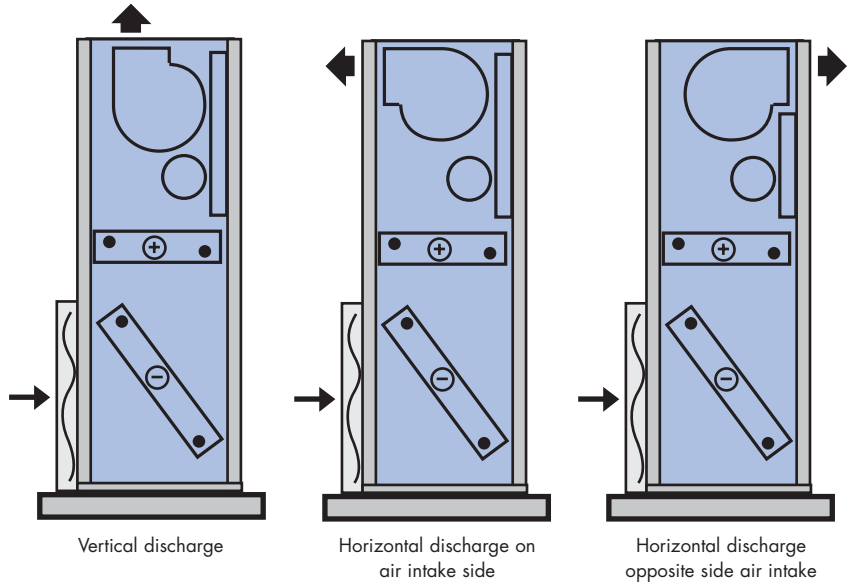

VVA Vertical air intake

Left hand side access

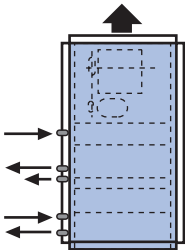

Right hand side access

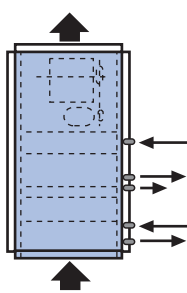

Rising vertical air flow

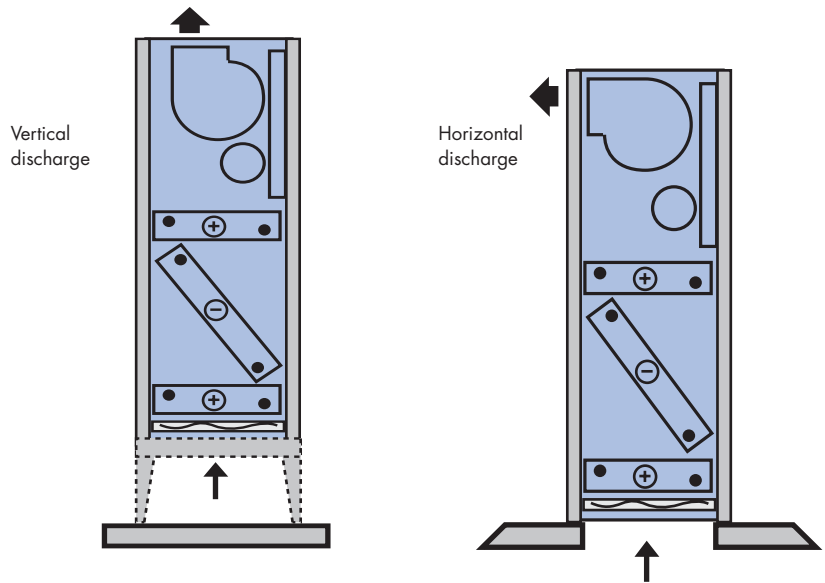

VVI Vertical air intake

Left or right hand side access

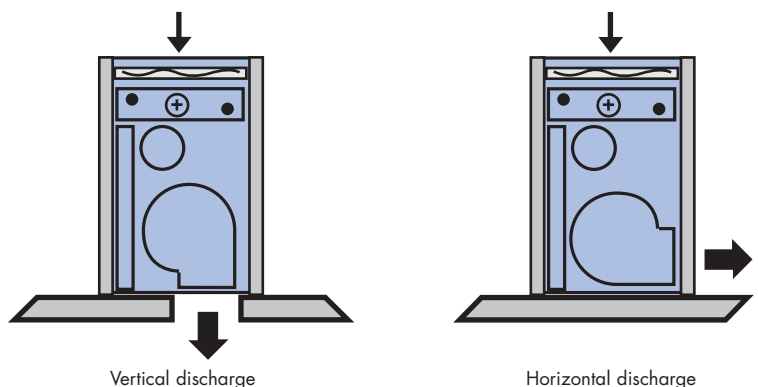

Note: Cooling coils are not available with this arrangement.

Dimensions - Air intake & Fan discharge

Air intake



CCM	A	B	A1	B1	C	D	E	F	G	H	I
20	545	905	1180	1810	345	675	100	3	235	2	187.5
45	855	905	1800	1810	675	675	90	3	235	3	235
65	855	1225	1800	2460	675	995	90	4	256.2	3	235
85	855	1545	1800	3100	675	1315	90	5	269	3	235
125	1175	1545	2440	3100	1005	1315	85	5	269	4	253.7
170	1495	1545	3080	3100	1335	1315	80	5	269	5	273
210	1495	1870	3080	3750	1335	1640	80	7	238.5	5	273
255	1495	2175	3080	4360	1335	1945	80	9	219.5	5	273
315	1845	2175	3780	4360	1665	1945	90	9	219.5	7	242.1

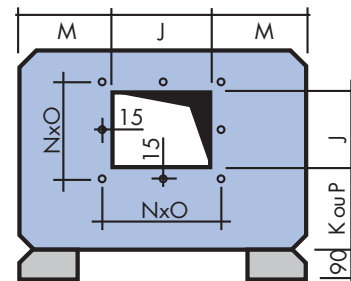
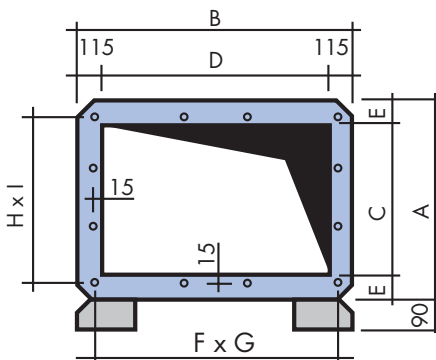

Holes for self tapping screws Ø6.3 mm for duct connection

Fan discharge

Nominal Fan

CCM	Type	J	K	M	N	O	P
20	200	305	159	300	2	167.5	80
45	250	371	183	267	2	200.5	80
65	315	453	219	386	3	161	80
85	355	502	239	521.5	3	177.3	80
125	450	618	309	463.5	3	216	80
170	500	687	331	429	5	143.4	80
210	560	764	368	553	5	158.8	90
255	630	850	414	662.5	5	176	90
315	710	947	570	614	5	195.4	180

Maximum Fan

CCM	Type	J	K	M	N	O	P
20	225	337	128	284	2	183.5	80
45	280	410	245	247.5	2	220	80
65	355	502	239	361.5	3	177.3	80
85	400	556	219	494.3	3	195.3	80
125	500	687	331	429	5	143.4	80
170	560	764	357	390.5	5	158.8	80
210	630	850	420	510	5	176	90
255	710	947	452	614	5	195	90
315	800	1056	627	544.5	7	155.1	180

Various discharge orientations

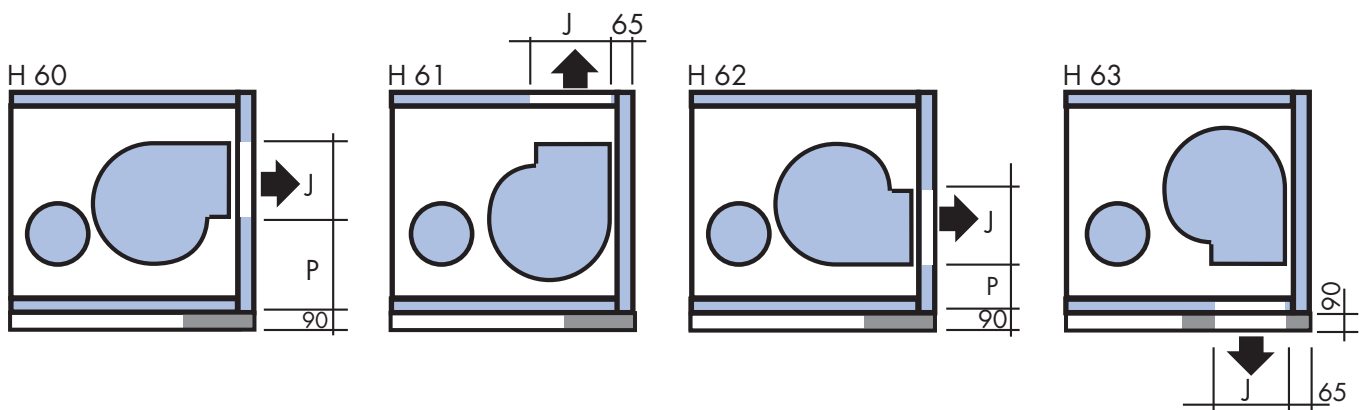

Note: These modules are always of the same length, with any orientation. **WARNING:** This length is valid for the motor sizes indicated on page 13 only.

Single air intake with internal damper

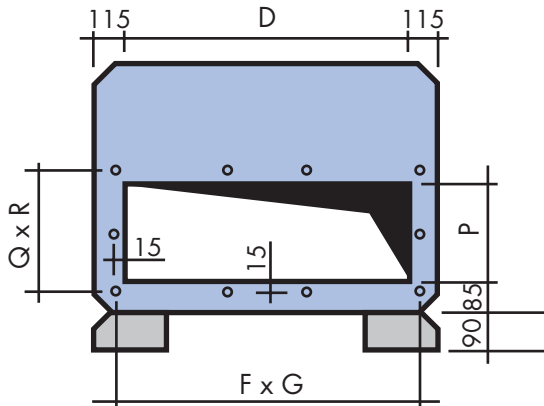

CCM	A1	D	F	G	P	Q	R	S
20	1180	675	3	235	160	1	190	180
45	1800	675	3	235	285	1	315	345
65	1800	995	4	256	285	1	315	345
85	1800	1315	5	269	285	1	315	345
125	2440	1315	5	269	405	2	217.5	510
170	3080	1315	5	269	525	2	277.5	675
210	3080	1640	7	238.5	525	2	277.5	675
255	3080	1945	9	219.5	525	2	277.5	675
315	3780	1945	9	219.5	675	3	235	675

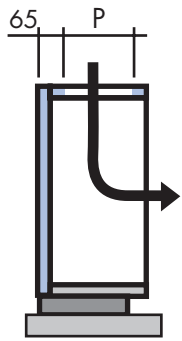

PUS

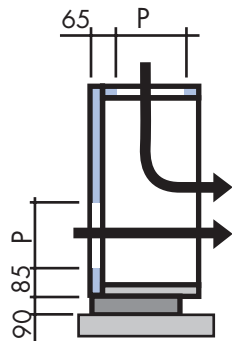

CM2 HS

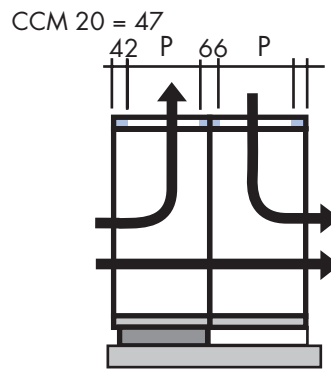

CM3 STD

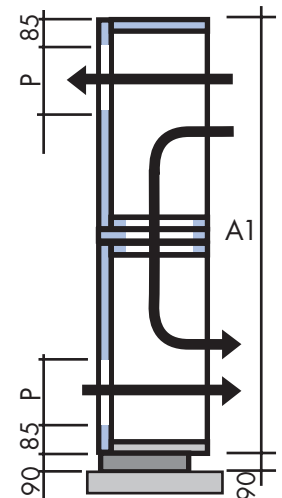

CM3 SUP

Single air intake within fan section, without damper, or with external damper

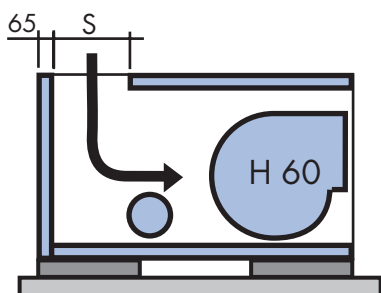

PUS and fan

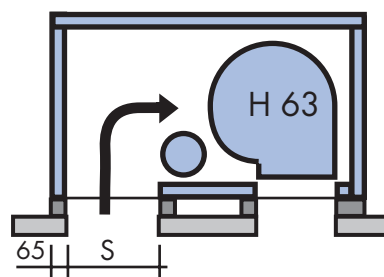

PUI and fan

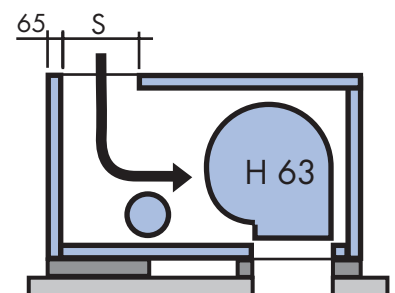

PUS and fan

Single lateral air intake / Lateral 2 way mixing section / Diagonal 3 way mixing section
- internal dampers

CCM 20 to 255

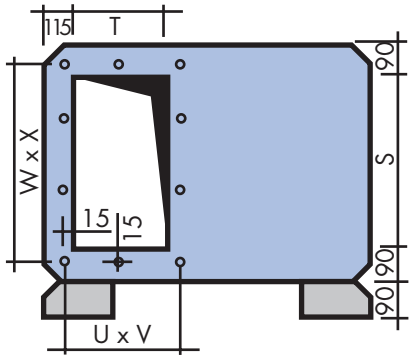

CCM 315

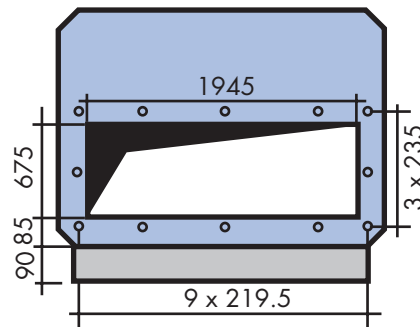

CCM 20 to 315

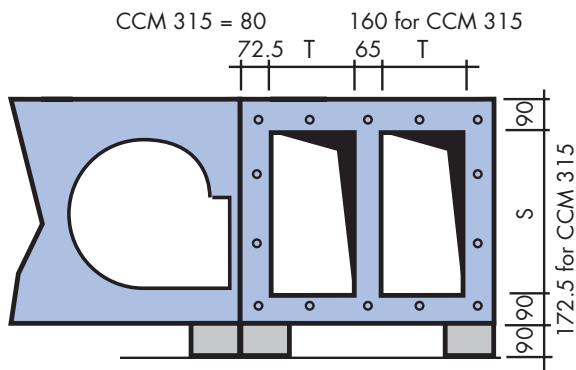
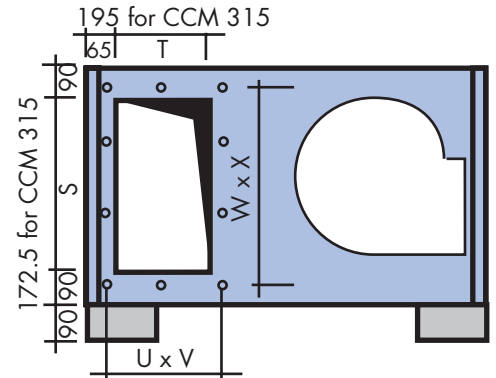

CCM	B1	S	T	U	V	W	X
20	1810	365	255	1	285	2	197.5
45	1810	675	255	1	285	3	235
65	2460	675	375	2	202.5	3	235
85	3100	675	495	2	262.5	3	235
125	3100	995	495	2	262.5	4	256.5
170	3100	1315	495	2	262.5	5	269
210	3750	1315	615	3	215	5	269
255	4360	1315	715	3	248.5	5	269
315	4435	1500*	840*	4	217.5	6	255

For lateral damper

CCM 315 = 195

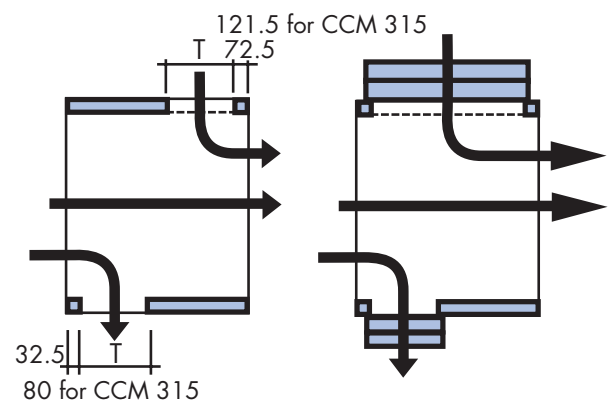
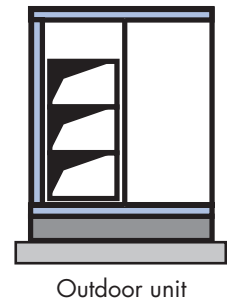
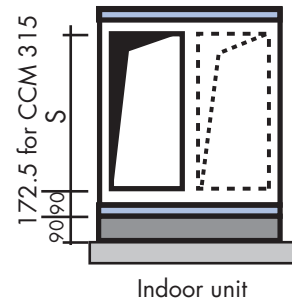
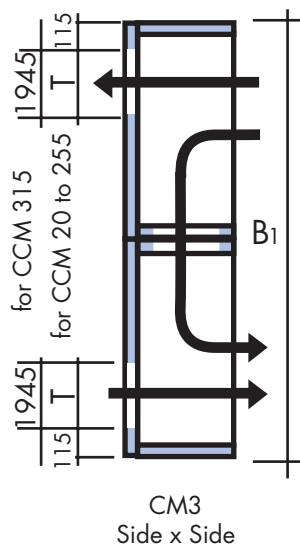
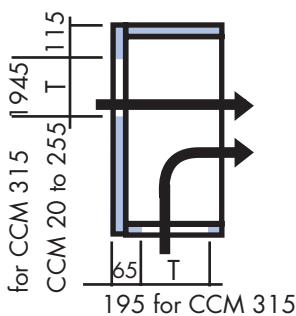
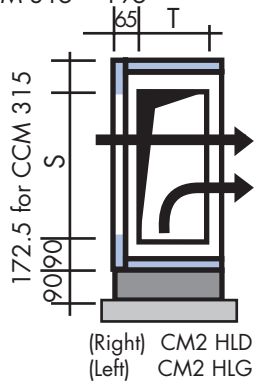

External dampers - 2 way mixing section

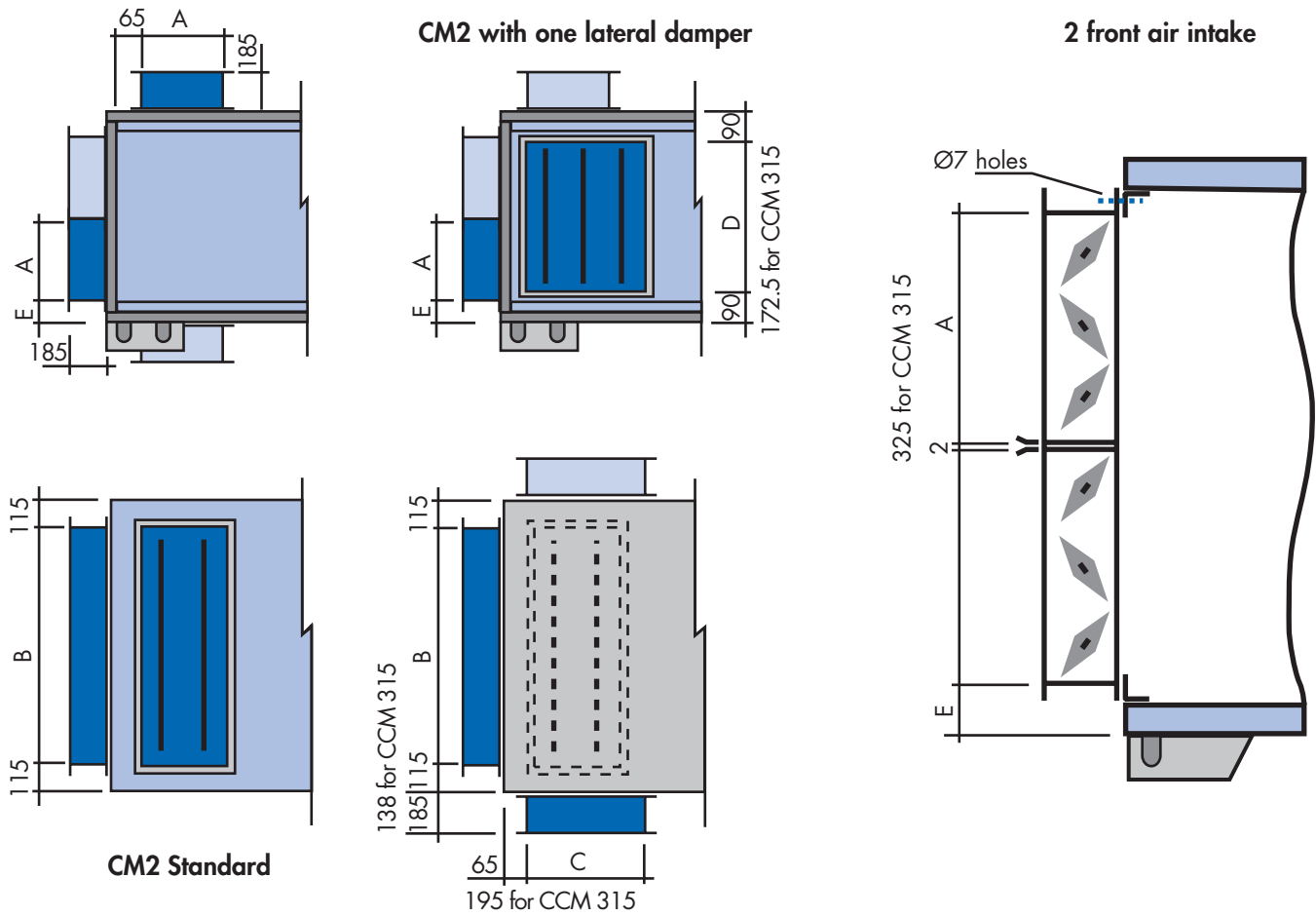

CCM	A	B	C	D	E	F	G	H	I	L	M	N	O
20	180	675	345	365	91.5	3	235	1	210	2	197.5	2	187.5
45	345	675	345	675	81.5	3	235	2	187.5	3	235	2	187.5
65	345	995	510	675	81.5	4	256	2	187.5	3	235	2	270
85	345	1315	675	675	81.5	5	269	2	187.5	3	235	3	235
125	510	1315	675	995	76.5	5	269	2	270	4	256.5	3	235
170	675	1315	675	1315	71.5	5	269	3	235	5	269	3	235
210	675	1640	840	1315	71.5	7	238.5	3	235	5	269	4	217.5
255	675	1945	840	1315	71.5	9	219.5	3	235	5	269	4	217.5
315	675	1945	840	1500	85	9	219.5	3	235	6	255	4	217.5

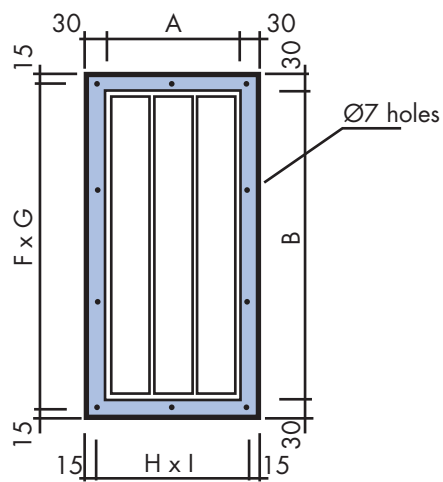

CM2 standard

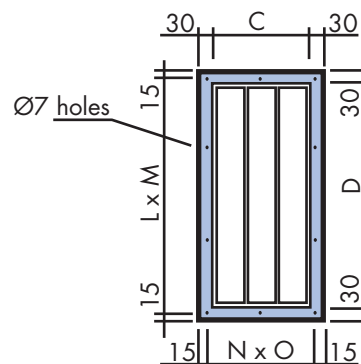

CM2 with one lateral damper

Manufactured to the same construction and design as indoor units, these air handling units have a metallic roof (Grey painted galvanised steel with varnish protection). The end of the roof is formed to shed rain water.

Tightness is achieved through a profile covering sealed cross section between two sections.

- Options :
- Suction intake hood
 - Discharge louvre
 - Intake hood on mixing box.

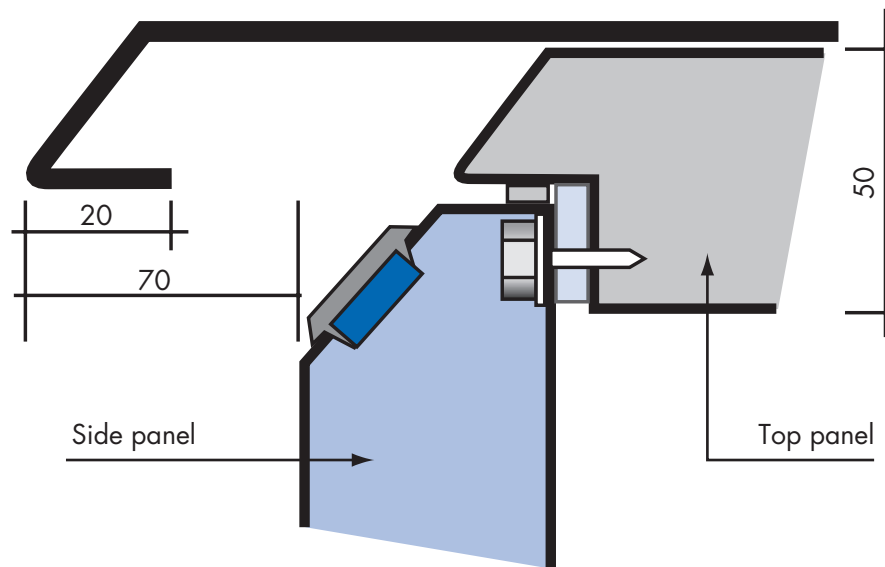

Roof extends 70 mm over the AHU top.



Roof connection between two parts of AHU

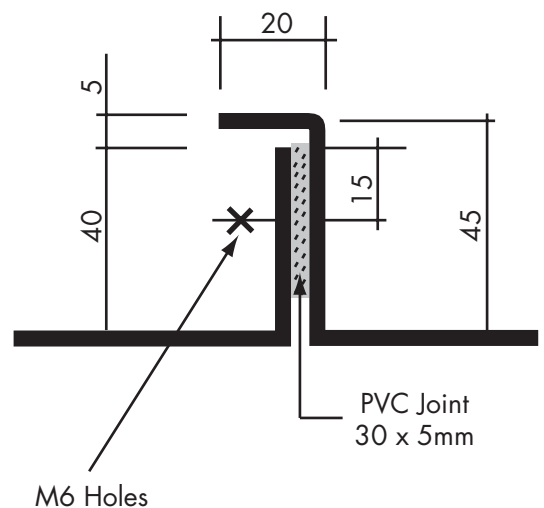

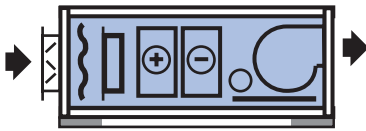
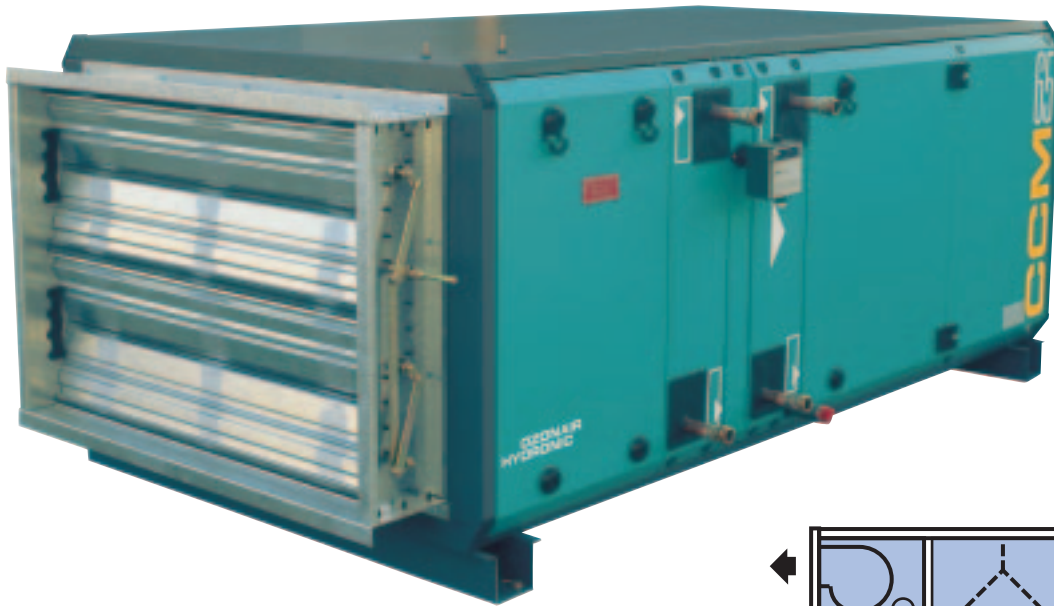

CCM65
Horizontal
Indoor
1 deck

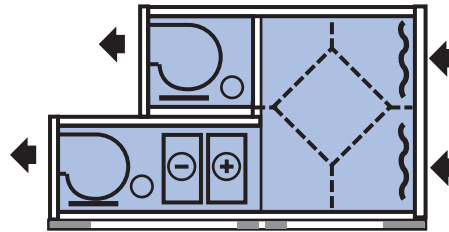

CCM20
Horizontal
Outdoor
Double deck unit with heat recuperator

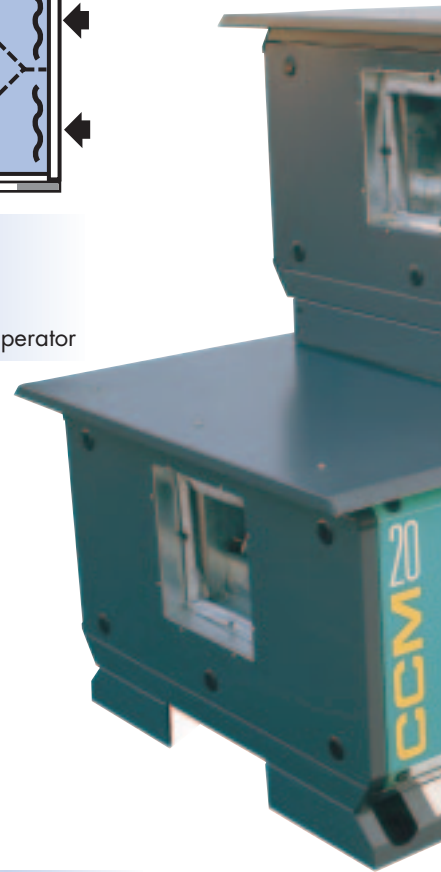

AIR



CCM65
Horizontal
Indoor
Double deck

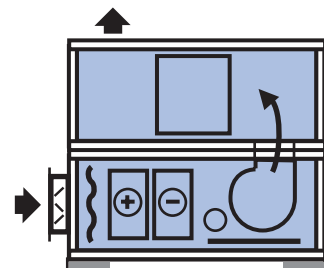

CCM range

Typical AHU arrangements

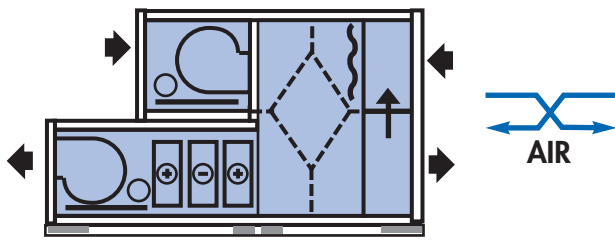

CCM125

Horizontal
Indoor

Double deck unit with heat recuperator

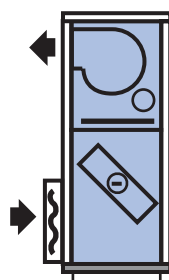

CCM125

Vertical
Indoor

Horizontal air intake and discharge



Weights of empty casing, including end panels. Standard construction.

Length	CCM								
	20	45	65	85	125	170	210	255	315
200	36	45	54	64	75	87	105	123	134
400	47	58	69	81	95	108	130	152	166
600	57	69	83	97	113	129	156	182	198
800	72	86	103	119	136	155	188	219	238
920	78	94	112	129	148	167	203	235	256
1000	82	99	118	136	156	175	212	247	269
1120	89	106	126	146	167	188	228	265	289
1200	93	111	133	153	175	196	238	276	301
1320	99	118	142	174	197	219	265	309	337
1400	104	124	148	181	205	228	276	321	350
1520	110	131	156	192	217	241	292	340	371
1600	114	137	163	200	225	250	303	352	384
1720	121	144	172	210	237	263	319	371	405
1800	125	149	178	217	244	271	329	382	416
1920	131	156	186	228	256	284	344	400	436
2000	136	162	193	235	264	293	355	413	450
2120	142	169	202	246	276	306	370	430	469
2200	146	174	208	253	284	314	380	442	482
2320	153	181	217	263	296	327	396	460	502
2400	157	186	222	270	304	336	407	473	516
2520	163	194	231	281	315	349	423	492	536
2600	167	199	238	288	323	357	432	503	548
2680	172	204	243	295	331	365	442	514	560

Weights for service box

Functional length L1 width 355	CCM								
	20	45	65	85	125	170	210	255	315
1000	31	36	36	36	46	53	53	53	65
2000	56	61	61	61	79	90	90	90	110
2680	73	78	78	78	102	116	116	116	148
L2 width 730									
1000	49	59	59	59	68	78	78	78	95
2000	92	106	106	106	119	135	135	135	165
2680	116	134	134	134	150	168	168	168	205

Motor weights

Motor weights - 1500 rpm (4 poles)															
Capacity (kW)	0.75	1.1	1.5	2.2	3	4	5.5	7.5	9	11	15	18.5	22	30	37
Frame Size	80	90	90	100	100	112	132	132	132	160	160	180	180	200	225
Weight (Kg)	10.5	14	15	19.5	22	26	39	56	62	80	97	113	135	170	205

Section	Description	CCM								
		20	45	65	85	125	170	210	255	315
Fan section	Fan with frame without motor - FC Nom	9	15	25	33	60	73	91	115	145
	Fan with frame without motor - FC Max	11	20	33	39	73	91	115	145	180
	Fan with frame without motor - BC Nom	10	16	27	36	64	77	95	120	150
	Fan with frame without motor - BC Max	12	22	36	42	77	96	120	150	185
	Expansion section with or without access	See empty casing weights								
	Discharge hood	4	5	7	9	12	15	18	22	26
	Discharge plenum	4	6	8	10	13	20	25	29	34
Sound attenuators	600 mm long attenuator	14	22	33	44	61	78	98	117	142
	900 mm long attenuator	20	32	47	63	89	114	143	171	142
	1200 mm long attenuator	26	42	62	83	116	150	188	225	274
	1500 mm long attenuator	31	51	76	102	144	186	233	280	342
Energy recovery	Vertical plate recuperator without by-pass	139	230	287	395	509	717	868	1010	1180
	Complete section weight with by-pass	149	257	320	392	598	720	872	1015	1190
	Horizontal plate recuperator without by-pass	180	228	353	520	617	730			
	Complete section weight with by-pass	222	280	472	692	829	963			
	Vertical heat pipes without by-pass - 4R	202	253	322	386	464	540	653	760	880
	Complete section weight with by-pass - 6R	212	274	351	426	521	613	742	863	995
	Vertical heat pipes with by-pass - 4R	240	298	376	416	506	618	748	870	1002
	Complete section weight with by-pass - 6R	249	316	399	484	581	676	820	952	1118
	Horizontal heat pipes without by-pass - 4R	172	232	276	333	400	458	555	645	785
	Complete section weight with by-pass - 6R	181	253	300	349	415	476	576	670	778
	Horizontal heat pipes with by-pass - 4R	212	285	344	408	484	562	680	790	905
	Complete section weight with by-pass - 6R	223	306	368	421	510	577	698	812	840
	Flexible connection - Inlet	2	2.5	3	3.5	4	4.5	5.5	6.5	8
	Flexible connection - Mixbox	3	4	4.5	5	6	7	8	9	10
	Flexible connection - Fan Discharge	1	1.5	2	2	2.5	3	3.5	4	5
Heating or cooling coil	1 row coil	16	24	30	37	47	58	71	82	102
	2 row coil	19	30	39	47	63	89	108	108	135
	3 row coil	22	36	47	58	81	110	134	155	193
	4 row coil	25	42	55	70	97	131	159	185	231
	6 row coil	34	57	76	97	141	190	230	268	335
	8 row coil	43	73	99	125	180	238	289	335	410
	10 row coil	53	90	122	154	223	291	352	410	512
	12 row coil	64	108	145	184	268	355	430	500	625
	14 row coil	76	127	168	215	315	420	509	592	740
	Electric heater battery	1 row battery - minimum capacity	12	19	25	31	45	61	75	86
1 row battery - maximum capacity		18	32	44	56	82	110	133	155	181
2 row battery - minimum capacity		24	38	54	69	94	134	163	189	295
2 row battery - maximum capacity		30	58	82	106	156	208	252	283	343
	Thermal protection	4	6	9	11	14	17	21	25	30
Elim.	Water drop eliminator Metallic Mesh	4	6	9	11	14	17	21	25	30
	Water drop eliminator Polypropylene	4	6	9	11	14	17	21	25	30
Humidifier	Wet deck humidifier - $\eta = 60\%$	40	65	75	85	95	135	164	190	205
	Wet deck humidifier - $\eta = 80\%$	50	75	85	125	135	175	212	247	277
	Wet deck humidifier - $\eta = 90\%$	70	100	115	185	195	235	285	331	376
	Steam humidifier - Empty section	See empty sections table								
Intake	Intake hood	9	13	16	19	30	39	47	55	62
	Intake hood with damper	28	37	44	59	77	99	120	140	168
	Hood for mixing section	3	5	7	8	13	16	20	23	26
	Anti-frost damper, fire damper or balancing damper	19	24	28	40	47	60	73	85	95
Mixing	Standard internal 2-way dampers	15	22	28	35	50	68	82	96	108
	Internal lateral 2-way dampers	15	22	28	35	50	68	82	96	108
	Internal single air intake damper	8	11	14	18	25	34	41	48	54
	Standard internal 3-way dampers	23	38	45	51	77	102	124	144	164
	External 2 way damper	29	38	48	57	69	81	98	155	171
	Double deck or side by side - 3 way dampers	23	38	45	51	77	102	124	144	161
	Diagonal 3-way dampers	28	42	50	54	80	105	127	148	166
Filters	Prefilter GM 65%	5	6	9	11	15	18	22	26	35
	Prefilter GS 95%	5	6	8	12	16	18	22	26	35
	Dual prefilters	9	11	15	20	29	34	42	48	70
	Short bag	8	10	14	17	30	32	40	48	64
	Rigid bag	11	14	21	25	44	48	60	72	107
	Long bag	8	10	14	17	30	32	40	48	74
	Prefilter in bag frame	5	6	8	12	16	18	22	26	39
	Absolute filters	23	35	55	67	107	129	162	194	280
	Activated carbon filters	26	45	68	87	143	169	212	254	348
	Sand filters	18	28	37	47	64	82	99	116	222
	Access	Included in casing								

Incorporation statement

(Article 4, paragraph 2 of modified directive 89/392/CEE) (1)

Ozonair Hydronic
71 High Street, Nailsea,
Bristol BS48 1AW

HYDRONIC declares that the air handling units types CCM, CTB2, CTHb & CTH and ancillaries, should **not** be put into operation until the installation, in which it has been fitted, has been declared to conform to the modified (1) 'Machinery Directive' 89/392/CEE

HYDRONIC declares that the equipment is in accordance with the provisions of the directives
'EMC' N° 89/336/CEE modified (2)
'Low voltage' N° 73/23/CEE modified (3)

(1) 89/392/CEE modified 91/368/CEE, 93/44/CEE, 93/68/CEE, 98/37/CEE

(2) 89/336/CEE modified 92/31/CEE, 93/68/CEE, 98/13/CEE

(3) 73/23/CEE modified 93/68/CEE