

CIRRUS



CIRRUS

The CIRRUS range of air handling units are principally designed for internal mounting arrangements where space is at a premium, such as ceiling voids, refurbishment projects or where there is limited headroom. The slim profile of the CIRRUS units means they are perfect where top or bottom access is required.

With six standard model sizes and a duty range of up to 1.0 m³/sec, the CIRRUS range is designed to suit most typical applications in the building services sector.

Each unit is constructed from a 'Pentapost' framework, comprising an aluminium frame and purpose built corners, for strength and style, with double skinned panels that provide a rigid construction for the unit's internal components.

Standard CIRRUS air handling unit components comprise either single or twin direct drive forward curved centrifugal fans, a pleated panel filter and L.P.H.W. Coil or Electric Heater battery dependant upon model selection.

CIRRUS Internal mounted direct drive ceiling void unit with pleated panel filter and electric heater battery.



CIRRUS Direct Drive Air Handling Unit

FEATURES & BENEFITS

CIRRUS INTERNAL MOUNTED UNIT



FEATURES & BENEFITS

- * Low profile of unit is ideal for ceiling mounting, where space is at a premium, with top or bottom access to facilitate easy fan and filter maintenance.
- * Excellent performance characteristics with air volumes of up to 1.0 m³/sec.
- * Rigid aluminium framework with purpose built corners for strength and style.
- * Standard components include forward curved single inlet fans, electric or hot water heaters and panel filters, with a comprehensive range of accessories.
- * Slide rails allow installation and regular maintenance of standard components with minimal effort.
- * A cost effective, fast build alternative to welded steel frame air handling units.
- * Fan, filter and heater all within one casing, therefore easier to install.
- * A flexible modular construction which provides an easier on site build option.
- * Double skinned panels with smooth, clean lined outer skins to create an attractive, quality appearance and finish.
- * A framing structure which enables versatility in design by providing hanging, stacking or joining configurations.
- * Units are acoustically and thermally lined.
- * A wide range of heater outputs are available.
- * Matching silencers are available to fit onto the inlet or outlet of the unit via a spacer section.

CIRRUS Direct Drive Air Handling Unit COMPONENT SPECIFICATION

CASING

General

The Cirrus range of Air Handling units are for internal mounting arrangements. Access, to be specified at the time of ordering, can be from above or below the unit, with hinged access panels optional if required. Although units have galvanised casings as standard, they can be supplied with plastisol coated steel outer skins upon request.

Panels are flush mounted into the unit framework rebates on a crush resistant closed cell neoprene sealing gasket, which provides an air seal between the panel and the component section. Gaskets are chemically and biologically inert and meet all requirements of DW 144.

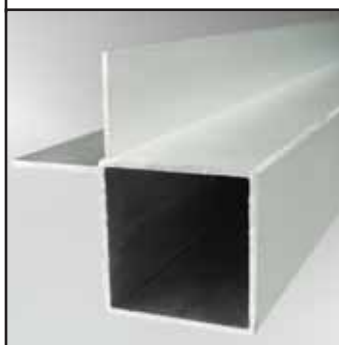

Extruded
Aluminium
Section

High Density
Nylon Corner



components and casing panels are mounted. All access panels are held firmly in place on the framework by means of fasteners, which exert pressure evenly between the panels and sealing gasket. Access panels are lift off type with Allen key operated 'quick release' fasteners, while all other fixed panels are retained with roofing bolts, sealed using a high modulus acetoxycure silicone sealant to BS 5889 Type B.

Handles are fitted to access panels as standard for ease of handling and removal from the air handling unit framework, which facilitates access to components for regular maintenance.

Access panels can be hinged if required at no extra cost, which enables servicing of the unit without having to completely remove the panel.

Infill panels are double skinned, constructed from 1.0mm thick pre galvanised sheet steel to BS 2989 Z2 inner and outer skins, using a sandwich construction enclosing 25mm of 65kg/m³ mineral wool insulation, which is completely encapsulated between the steel sheets to provide acoustic and thermal insulation.

N.B. Fan access and filter removal can be from the top or bottom.

Extruded
Aluminium
Section
Framework With
High Density
Nylon Corner



Double Skinned
Insulated Panel

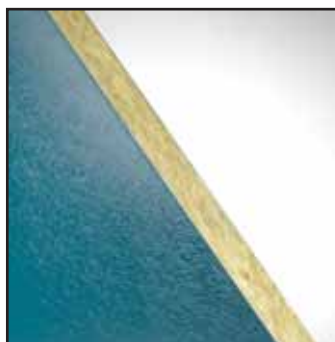

Internal Units

The CIRRUS Direct Drive Air Handling units have an AA25 anodised finish extruded aluminium section, constructed from a 30mm framework with a wall thickness of 1.5mm.

The mullion section is used between access panels and where panels are joined as part of the pentapost framework. The mullion is constructed from an AA25 Anodised finish extruded aluminium section, with a wall thickness of 1.5mm

The specially designed durable corner sections for the 30mm framework are manufactured from black high density glass reinforced nylon, providing a framework of strength and rigidity, onto which all internal

CIRRUS Direct Drive Air Handling Unit

COMPONENT SPECIFICATION Cont...

FANS & MOTORS

The fans are mounted onto a diaphragm plate, are double inlet double width or single inlet single width forward curved centrifugal, housed in a purpose designed scroll with integral deep drawn inlet cones to facilitate maximum efficiency.

All fans are suitable for either 230V/1Ph/50Hz or for 400V/3Ph/50Hz electrical supply.

The fans are suitable for operating temperatures of up to +40°C.

The motors are isolated from the unit case and have anti-vibration mounts fitted between the motor mounting arm and the fan casing. All wheels are dynamically balanced.



FILTERS

Pleated Panel filters are 100mm deep disposable type to Grade G4, in accordance with BS EN 779 1993 (EU4) and have a maximum operating temperature of 100 °C.

They are for side, top or bottom withdrawal, mounted into the unit on slide rails, which are manufactured from pre-galvanised sheet steel to enable filter replacement.

Pleated Panel filters are manufactured from pleated media which consists of reinforced non-woven fibres, with expanded diamond grid to provide maximum support. Pleating the media effectively increases the filtration area to more than three times that of the face area, providing high dust holding capacity and low pressure loss. The pleat pack is encased in a water resistant lattice cardboard frame.

HEATERS

Hot Water Heating Coils (L.P.H.W.)

Coils are constructed from seamless drawn copper tube to BS 2871 mechanically expanded into aluminium fins with die formed self spacing collars. The coil casing is formed from heavy gauge galvanised sheet to BS 2989 to make a rigid assembly, with BSP(M) pipe fittings on coil flow and return connections. Tube end plates have die formed collared holes to allow expansion and contraction of the tubes without damage.

All coils are subjected to an air under water test to 16 bar during manufacture.

All coil sections are fitted into the units on pre-galvanised slide rails for ease of assembly and withdrawal.

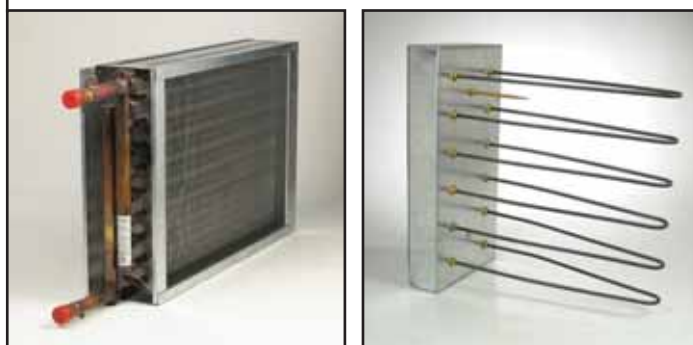

Electric Heater Batteries (E.H.B.)

Elements are constructed from Nichrome 5 spiral resistance wire surrounded by magnesium oxide powder and sheathed in stainless steel.

The elements are mounted on a galvanized sheet steel terminal housing.

All electric heaters are fitted with high temperature thermal cut out protection for wiring into the control circuit and are generally available in the power and number of steps required.

A control system must be provided to ensure the heater is not activated when there is no airflow and the fan runs on after the heater has been switched off, to dissipate any residual heat. It is recommended that a fan run on timer be incorporated within the controls to prevent possible heat damage, as well as an airflow switch.



Fastlane will build to the space and specification of your choosing; everything, from insulated panels, to the style of door fittings, from filter grade, fan selection to weatherproofing; each component designed so your Fastlane Air Handling Unit will integrate with the application

CIRRUS Direct Drive Air Handling Unit

PERFORMANCE & ELECTRICAL DATA

Fan, Filter & L.P.H.W. Heater Battery

Model	Air Volume m ³ /sec @ Static Pressure Pa												
	0	50	75	100	125	150	175	200	250	300	350	400	450
CSHW 10	-	-	0.264	0.257	0.250	0.239	0.231	0.219	0.197	0.181	0.153	0.125	0.081
CSHW 20	0.563	0.535	0.521	0.508	0.500	0.486	0.472	0.458	0.417	0.375	0.333	0.236	0.194
CSHW 30	0.583	0.558	0.544	0.531	0.517	0.506	0.494	0.475	0.450	0.414	0.361	0.306	0.211
CSHW 40	0.733	0.717	0.706	0.697	0.683	0.669	0.661	0.650	0.625	0.590	0.556	0.519	0.472
CSHW 50	1.061	1.014	0.986	0.972	0.953	0.931	0.889	0.861	0.814	0.736	0.639	0.528	0.372
CSHW 60	0.856	0.833	0.811	0.797	0.783	0.778	0.764	0.750	0.731	0.694	0.653	0.625	0.569

Fan, Filter & Electric Heater Battery

Model	Air Volume m ³ /sec @ Static Pressure Pa												
	0	50	75	100	125	150	175	200	250	300	350	400	450
CSE 10	-	-	-	0.260	0.252	0.241	0.233	0.220	0.198	0.181	0.153	0.124	0.079
CSE 20	0.600	0.580	0.563	0.540	0.535	0.521	0.508	0.490	0.458	0.400	0.360	0.300	0.194
CSE 30	0.620	0.593	0.585	0.575	0.558	0.544	0.531	0.500	0.475	0.440	0.361	0.306	0.211
CSE 40	0.743	0.725	0.717	0.706	0.697	0.683	0.669	0.661	0.630	0.593	0.558	0.519	0.472
CSE 50	1.140	1.102	1.061	1.040	1.014	0.977	0.970	0.952	0.862	0.793	0.641	0.528	0.370
CSE 60	0.861	0.856	0.835	0.820	0.800	0.795	0.780	0.778	0.750	0.710	0.653	0.625	0.569

Fan, Filter & L.P.H.W. / E.H.B Electrical

Model	Motor kW	FLC Amps	SC Amps	Speed r/min	Supply V-Ph-Hz
CSHW 10 / CSE 10	0.31	1.35	5.40	1990	230 - 1 - 50
CSHW 20 / CSE 20	0.37	5.60	14.00	1380	230 - 1 - 50
CSHW 30 / CSE 30	1.20	2.15	5.72	1240	400 - 3 - 50
CSHW 40 / CSE 40	1.56	7.00	11.20	1135	230 - 1 - 50
CSHW 50 / CSE 50	0.75	11.20	28.00	1380	230 - 1 - 50
CSHW 60 / CSE 60	2.45	4.50	12.60	1270	400 - 3 - 50

Fan Outlet Sound Power Levels

Model	Octave band centre frequencies Hz							
	63	125	250	500	1K	2K	4K	8K
CS 10	83	78	73	74	73	67	67	80
CS 20	73	77	85	77	80	77	76	70
CS 30	88	87	83	81	77	73	67	59
CS 40	90	89	85	83	79	75	69	61
CS 50	76	81	88	80	83	80	79	74
CS 60	92	89	89	87	83	79	73	65

CIRRUS Direct Drive Air Handling Unit

PERFORMANCE DATA

L.P.H.W. Heater Battery

Performance data for standard 2 row LPHW heaters at 82deg C flow 71 deg C return

Model	Air on Temp	Leaving Air Temperature deg. C @ m ³ /sec												
		0.1	0.15	0.2	0.25	0.3	0.35	0.4	0.5	0.6	0.7	0.8	0.9	1.0
CSHW 10	-5C	40	40	38	33	-	-	-	-	-	-	-	-	-
	0C	40	40	40	36	-	-	-	-	-	-	-	-	-
CSHW 20	-5C	40	40	38	33	29	27	24.5	21	-	-	-	-	-
	0C	40	40	40	36	32	29.5	27.5	24.5	-	-	-	-	-
CSHW 30	-5C	40	40	38	33	29	27	24.5	21	-	-	-	-	-
	0C	40	40	40	36	32	29.5	27.5	24.5	-	-	-	-	-
CSHW 40	-5C	40	40	40	40	40	40	37.5	33	29.5	25	-	-	-
	0C	40	40	40	40	40	40	40	36.5	32.5	28.5	-	-	-
CSHW 50	-5C	40	40	40	40	40	40	37.5	33	29.5	25	23	21	19
	0C	40	40	40	40	40	40	40	36.5	32.5	28.5	26	24	22
CSHW 60	-5C	40	40	40	40	40	40	37.5	33	29.5	25	23	-	-
	0C	40	40	40	40	40	40	40	36.5	32.5	28.5	26	-	-

To prevent damage to the fan motor(s) the maximum off coil temperature should be limited to a maximum of 40 deg C.

Other duties are available, please enquire.

Electric Heater Battery

Model	Air Vol m ³ /sec	kW Rating	Single Phase Supply Steps				Three Phase Supply Steps		
			1	2	3	4	1	2	3
CSE 10	0.08	3.0	✓	✓	✓		✓		
	0.12	4.5	✓		✓		✓		
	0.17	6.0	✓	✓	✓		✓	✓	
CSE 20	0.21	7.5	✓		✓		✓	✓	
	0.25	9.0	✓	✓	✓		✓	✓	✓
	0.33	12.0	✓	✓	✓	✓	✓	✓	
CSE 30	0.41	15.0	✓	✓	✓		✓	✓	
	0.50	18.0	✓	✓	✓	✓	✓	✓	✓
	0.62	22.5	✓		✓		✓		✓
CSE 40	0.17	6.0	✓	✓	✓		✓	✓	
	0.21	7.5	✓		✓		✓	✓	
	0.25	9.0	✓	✓	✓		✓	✓	✓
CSE 50	0.33	12.0	✓	✓	✓	✓	✓	✓	
	0.41	15.0	✓	✓	✓		✓	✓	
	0.50	18.0	✓	✓	✓	✓	✓	✓	✓
CSE 60	0.62	22.5	✓		✓		✓		✓
	0.66	24.0	✓	✓	✓	✓	✓		
	0.75	27.0	✓		✓		✓		✓

N.B. Please enquire for duty and steps not shown.

The heater battery should be provided with a control system to prevent the heater being activated with no airflow and a fan run on timer to dissipate residual heat after the heater is switched off.

To prevent damage to the fan motor(s) the maximum off coil temperature should be limited to 40 deg C.

Other duties are available, please enquire.

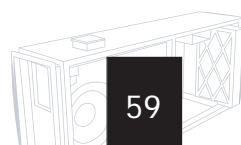

CIRRUS Direct Drive Air Handling Unit PERFORMANCE CURVES

Fan, Filter & L.P.H.W. Heater Battery

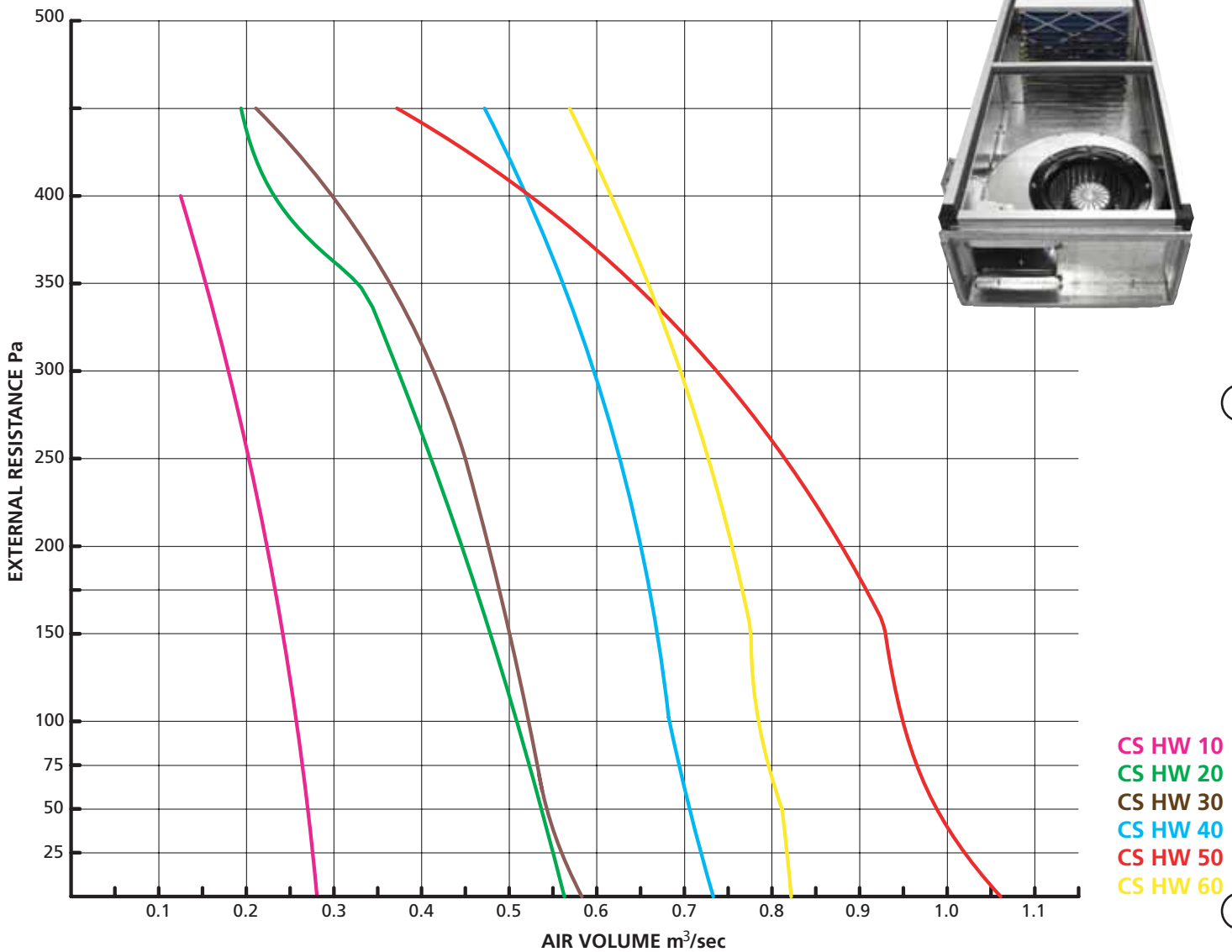

- CS HW 10
- CS HW 20
- CS HW 30
- CS HW 40
- CS HW 50
- CS HW 60



FAN

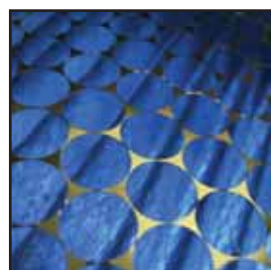

FILTER



L.P.H.W.

CIRRUS Direct Drive Air Handling Unit

PERFORMANCE CURVES

Fan, Filter & Electric Heater Battery

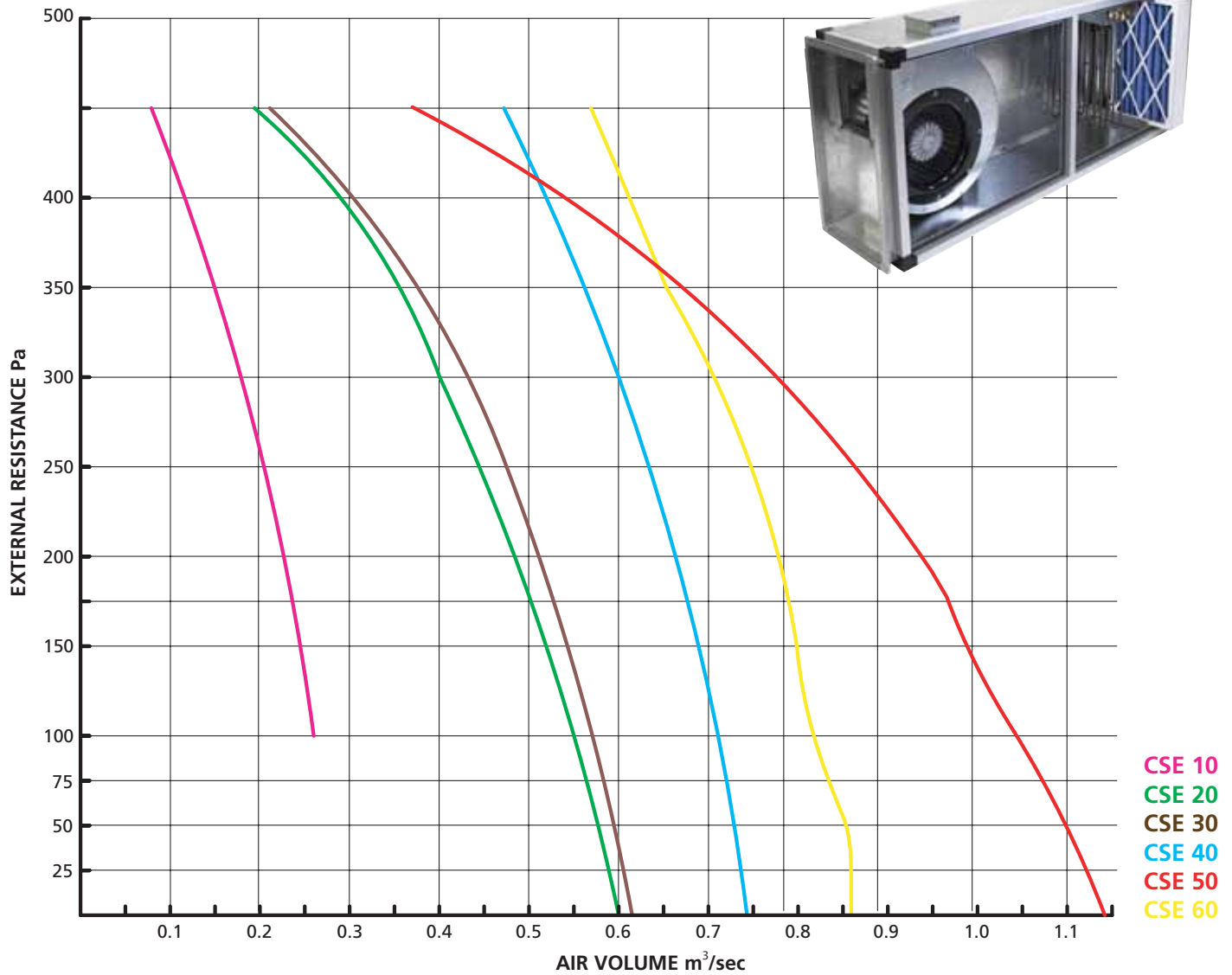

FAN

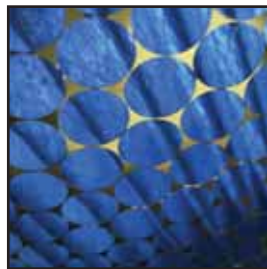

FILTER



E.H.B.

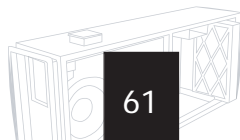

CIRRUS Air Handling Unit Component Section

PERFORMANCE DATA

Resistance (Pa) for optional intake damper (damper fully open)

Model	Air Volume m ³ /sec												
	0.1	0.15	0.2	0.25	0.3	0.35	0.4	0.5	0.6	0.7	0.8	0.9	1.0
CS 10	1.0	1.5	2.5	4.0	-	-	-	-	-	-	-	-	-
CS 20	1.0	1.5	2.5	4.0	6	8	10	15	-	-	-	-	-
CS 30	1.0	1.5	2.5	4.0	6	8	10	15	-	-	-	-	-
CS 40	0.5	0.5	1	1.5	2	2.5	3.5	5	7.5	10	-	-	-
CS 50	0.5	0.5	1	1.5	2	2.5	3.5	5	7.5	10	12.5	16	20
CS 60	0.5	0.5	1	1.5	2	2.5	3.5	5	7.5	10	12.5	-	-

Resistance (Pa) for optional mixing box (side and end dampers)

Model	Air Volume m ³ /sec												
	0.1	0.15	0.2	0.25	0.3	0.35	0.4	0.5	0.6	0.7	0.8	0.9	1.0
CS 10	1.0	1.5	2.5	4.0	-	-	-	-	-	-	-	-	-
CS 20	1.0	1.5	2.5	4.0	6	8	10	15	-	-	-	-	-
CS 30	1.0	1.5	2.5	4.0	6	8	10	15	-	-	-	-	-
CS 40	0.5	0.5	1	1.5	2	2.5	3.5	5	7.5	10	-	-	-
CS 50	0.5	0.5	1	1.5	2	2.5	3.5	5	7.5	10	12.5	16	20
CS 60	0.5	0.5	1	1.5	2	2.5	3.5	5	7.5	10	12.5	-	-

Resistance (Pa) for optional F5 (EU5) 400mm long bag filter (resistance clean)

Model	Air Volume m ³ /sec												
	0.1	0.15	0.2	0.25	0.3	0.35	0.4	0.5	0.6	0.7	0.8	0.9	1.0
CS 10	13	20	26	33	-	-	-	-	-	-	-	-	-
CS 20	13	20	26	33	39	46	52	-	-	-	-	-	-
CS 30	13	20	26	33	39	46	52	-	-	-	-	-	-
CS 40	8	12	15	19	23	27	30	38	45	53	60	-	-
CS 50	8	12	15	19	23	27	30	38	45	53	60	-	-
CS 60	8	12	15	19	23	27	30	38	45	53	60	-	-

Resistance (Pa) for optional silencers

Model	Air Volume m ³ /sec												
	0.1	0.15	0.2	0.25	0.3	0.35	0.4	0.5	0.6	0.7	0.8	0.9	1.0
CS 10	3	6	11	17	-	-	-	-	-	-	-	-	-
CS 20	3	6	11	17	24	33	43	67	-	-	-	-	-
CS 30	3	6	11	17	24	33	43	67	-	-	-	-	-
CS 40	1	3	4	6	9	12	16	24	34	47	-	-	-
CS 50	1	3	4	6	9	12	16	24	34	47	61	77	95
CS 60	1	3	4	6	9	12	16	24	34	47	61	-	-

Static insertion loss for silencers dB

ALL Models	Length mm	Octave Band Centre Frequencies Hz							
		63	125	250	500	1000	2000	4000	8000
	600	-3	-7	-13	-21	-25	-27	-23	-13
	900	-6	-10	-18	-33	-40	-40	-36	-17
	1200	-7	-12	-23	-43	-45	-45	-45	-21
	1500	-8	-14	-28	-45	-45	-45	-45	-24
	1800	-9	-16	-33	-45	-45	-45	-45	-29

CIRRUS Direct Drive Air Handling Unit

DIMENSIONS

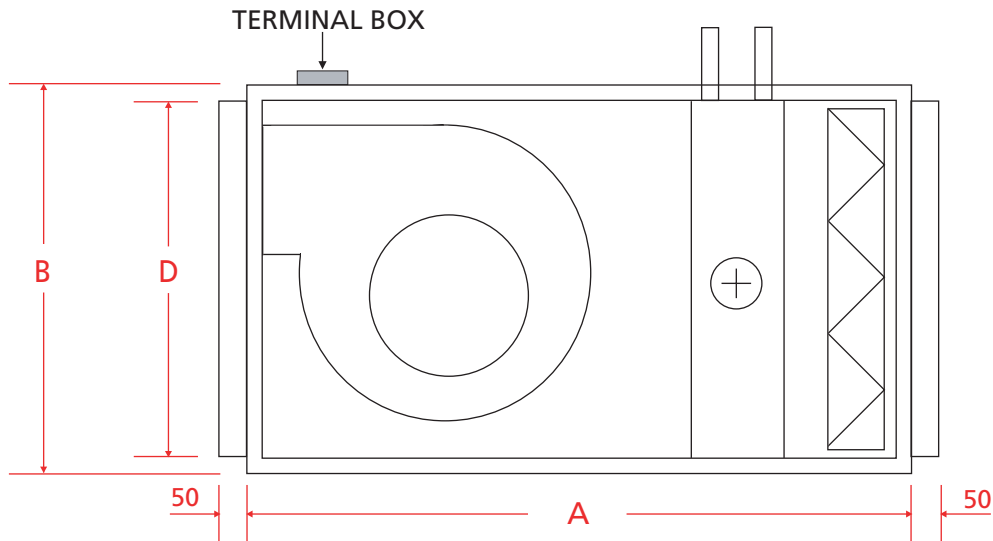

Plan

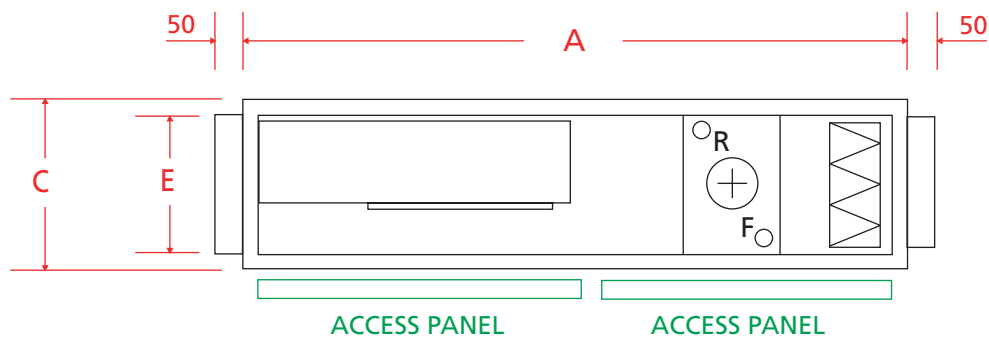

Side Elevation

Model	A	B	C	D	E	Weight kg*	
						L.P.H.W.	E.H.B.
CS 10	1500	660	360	600	300	87	84
CS 20	1500	660	360	600	300	88	85
CS 30	1500	660	360	600	300	108	110
CS 40	1600	1060	360	1000	300	156	162
CS 50	1600	1060	360	1000	300	131	138
CS 60	1600	1060	360	1000	300	157	163

N.B. All Dimensions in mm. Lengths exclude unit intake and discharge spigots.

*Specifies Weight with L.P.H.W or Electric Heater Battery Component

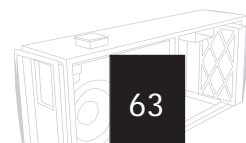

CIRRUS Direct Drive Air Handling Unit

COMPONENT SECTION DIMENSIONS

Model	Fan Section Only		Intake Damper		Mixing Box with 2 dampers		Bag Filter F5 (EU5)		Cooling Coil		
	Length	Weight	Length	Weight	Length	Weight	Length	Weight	Max. Air Vol. m ³ /sec	6 Row Coil	
										Length	Weight
CS 10	500	30	120	6	660	38	660	32	0.21	660	50
CS 20	700	40	120	6	660	38	660	32	0.21	660	50
CS 30	700	60	120	6	660	38	660	32	0.21	660	50
CS 40	800	86	120	8	1060	75	660	45	0.39	660	71
CS 50	700	55	120	8	1060	75	660	45	0.39	660	71
CS 60	800	87	120	8	1060	75	660	45	0.39	660	71

N.B. All Dimensions in mm.

Model	SILENCERS											
	Height	Width	Length	Weight	Length	Weight	Length	Weight	Length	Weight	Length	Weight
CS 10	300	600	600	19	900	29	1200	39	1500	49	1800	58
CS 20	300	600	600	19	900	29	1200	39	1500	49	1800	58
CS 30	300	600	600	19	900	29	1200	39	1500	49	1800	58
CS 40	300	1000	600	31	900	46	1200	61	1500	76	1800	92
CS 50	300	1000	600	31	900	46	1200	61	1500	76	1800	92
CS 60	300	1000	600	31	900	46	1200	61	1500	76	1800	92

N.B. All Weights in kg.

Discharge Spacer section is for fitting between supply fan outlet and supply air silencer.

Heights and widths exclude 25mm Ductmate flanges.

Model	Discharge Spacer Section		Flexible Connection			
	Length	Weight	Height	Width	Length	Weight
CS 10	250	4	300	600	130	5
CS 20	350	5	300	600	130	5
CS 30	400	6	300	600	130	5
CS 40	450	9	300	1000	130	7
CS 50	350	7	300	1000	130	7
CS 60	450	9	300	1000	130	7

N.B. All Dimensions in mm.

Discharge Spacer section is for fitting between supply fan outlet and supply air silencer.

Heights and widths exclude 25mm Ductmate flanges.

CIRRUS Air Handling Unit Component Section

SILENCER DIMENSIONS / PERFORMANCE

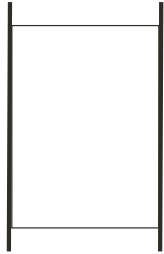

Discharge Spacer
for fitting between
unit discharge and
silencer.

All dimensions as
per silencer.

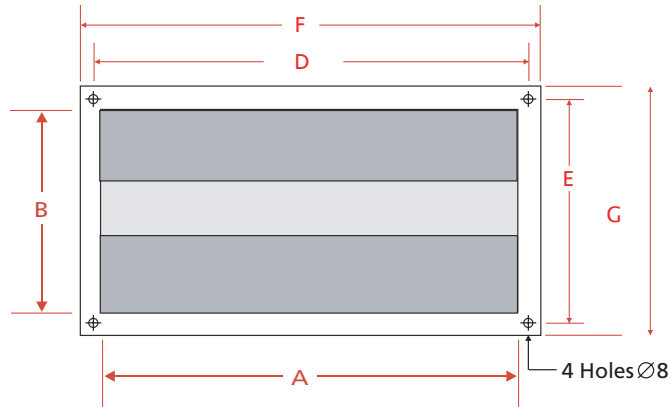

CONSTRUCTION

1.0mm Galvanised sheet steel casing

25mm Ductmate flanges.

Infill mineral wool with scrim facing and expanded mesh retainer.

	Model	A	B	Length	D	E	F	G	Airways	Silencer Weight kg	Spacer Section kg
CS 10	10-30-0600	600	300	600	620	320	650	350	1	19	4
	10-30-0900			900						29	4
CS 20	10-30-1200			1200						39	5
	10-30-1500			1500						49	5
CS 30	10-30-1800			1800						58	6

	Model	A	B	C	D	E	F	G	Airways	Silencer Weight kg	Spacer Section kg
CS 40	40-30-0600	1000	300	600	1020	320	1050	350	1	31	9
	40-30-0900			900						46	9
CS 50	40-30-1200			1200						61	7
	40-30-1500			1500						76	7
CS 60	40-30-1800			1800						92	9

Static Insertion Loss For Silencers

	Octave Band Centre Frequencies Hz								
	Length mm	63	125	250	500	1000	2000	4000	8000
ALL Models	600	-3	-7	-13	-21	-25	-27	-23	-13
	900	-6	-10	-18	-33	-40	-40	-36	-17
	1200	-7	-12	-23	-43	-45	-45	-45	-21
	1500	-8	-14	-28	-45	-45	-45	-45	-24
	1800	-9	-16	-33	-45	-45	-45	-45	-29

In accordance with our policy of constant product development we reserve the right to alter from published data without prior notice.

