



Singleflow SSDD & SSBD Installation and Maintenance Instructions

**THESE INSTRUCTIONS MUST BE READ FULLY BEFORE
COMMENCING INSTALLATION**

Code	Supply	FL Amps	Input kW	r/min
SSDD1/L	230V/1Ph/50Hz	0.37	0.085	2250
SSDD2/L	230V/1Ph/50Hz	0.43	0.098	1330
SSDD3/L	230V/1Ph/50Hz	1.20	0.25	1220
SSDD4/L	230V/1Ph/50Hz	2.70	0.50	1415
SSDD5/L	230V/1Ph/50Hz	4.40	0.96	1250
SSDD6/L	230V/1Ph/50Hz	5.20	1.10	1310
SSDD7/L	230V/1Ph/50Hz	7.00	1.40	820

Code	Supply	FL Amps	Output kW	Motor r/min
SSBD1	230V/1Ph/50Hz	2.2	0.25	4 pole
SSBD1/2	230V/1Ph/50Hz	3.0	0.37	4 pole
SSBD1/2/3/4	230V/1Ph/50Hz	4.4	0.55	4 pole
SSBD1/2/3/4	230V/1Ph/50Hz	5.5	0.75	4 pole
SSBD1/2/3/4	230V/1Ph/50Hz	7.6	1.1	4 pole

Code	Supply	FL Amps	Output kW	Motor r/min
SSBD1	400V/3Ph/50Hz	0.96	0.25	6 pole
SSBD1/2	400V/3Ph/50Hz	1.11	0.37	6 pole
SSBD1/2/3/4	400V/3Ph/50Hz	1.61	0.55	6 pole
SSBD1/2/3/4	400V/3Ph/50Hz	1.95	0.75	6 pole
SSBD1/2/3/4	400V/3Ph/50Hz	2.9	1.1	6 pole
SSBD2/3/4	400V/3Ph/50Hz	4.3	1.5	6 pole
SSBD2/3/4	400V/3Ph/50Hz	5.36	2.2	6 pole
SSBD3/4	400V/3Ph/50Hz	7	3	6 pole

Code	Supply	FL Amps	Output kW	Motor r/min
SSBD1	400V/3Ph/50Hz	0.78	0.25	4 pole
SSBD1/2	400V/3Ph/50Hz	1.06	0.37	4 pole
SSBD1/2/3/4	400V/3Ph/50Hz	1.42	0.55	4 pole
SSBD1/2/3/4	400V/3Ph/50Hz	1.77	0.75	4 pole
SSBD1/2/3/4	400V/3Ph/50Hz	2.71	1.1	4 pole
SSBD2/3/4	400V/3Ph/50Hz	3.26	1.5	4 pole

SSBD2/3/4	400V/3Ph/50Hz	4.74	2.2	4 pole
SSBD3/4	400V/3Ph/50Hz	6.2	3	4 pole

Code	A	B	C	D	E	F	G	Weight kg
SSDD1/L	400	375	210	125	125	200	425	10
SSDD2/L	425	500	260	150	150	225	550	16
SSDD3/L	425	500	260	200	200	225	550	22
SSDD4/L	475	550	300	250	250	275	600	28
SSDD5/L	575	700	440	315	315	375	750	33
SSDD6/L	700	800	460	400	400	500	850	36
SSDD7/L	850	900	570	500	500	650	950	52

Code	A	B	C	D	E	F	G	Weight kg
SSBD1/L	800	600	450	235	225	350	500	75
SSBD2/L	1000	800	550	300	265	450	650	90
SSBD3/L	1200	950	650	315	345	550	700	115
SSBD4/L	1200	1100	750	375	405	650	900	150

SSDD

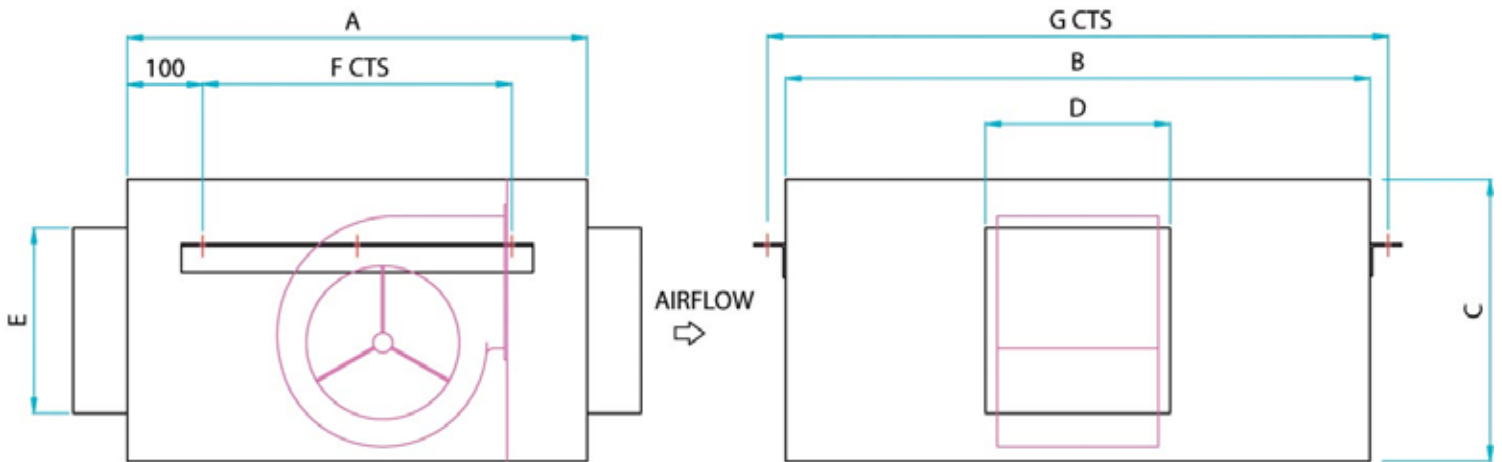

SSBD

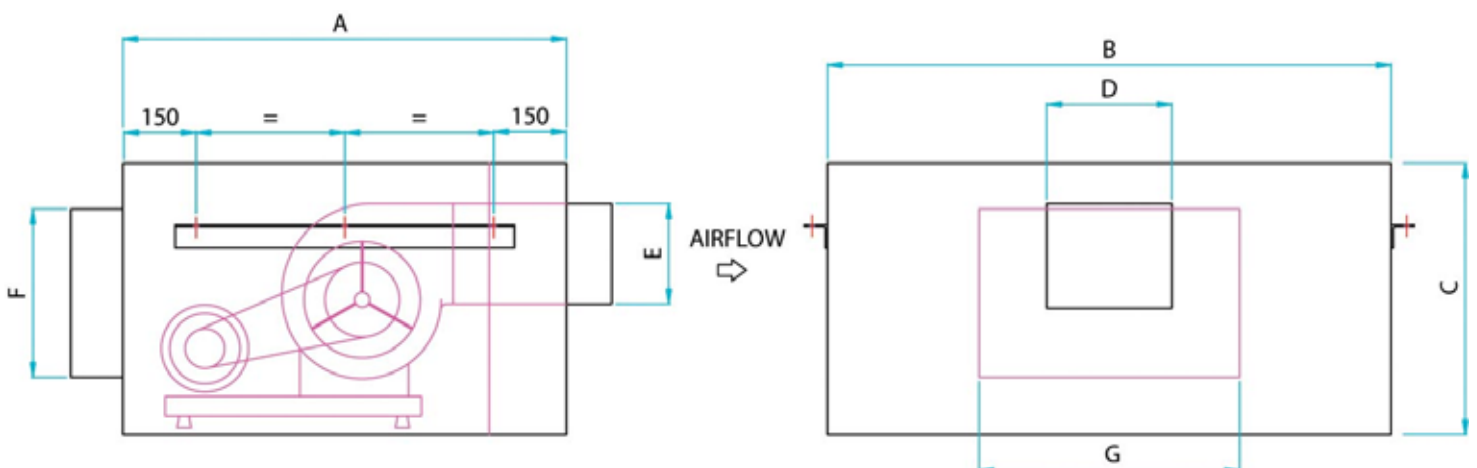

1.0 GENERAL

- 1.1 It is important these Installation and Maintenance Instructions are fully adhered to.
- 1.2 Full details of the unit supplied are shown on the product nameplate. If in doubt about any detail contact Elta Fans Ltd or its agents for clarification.
- 1.3 All electrical installation must be carried out by suitably qualified and competent personnel in accordance with all current statutory requirements.
- 1.4 These instructions cover only the Elta Fans Ltd product and do not include the supply or installation of any safety equipment that may be required e.g. adequate guarding or protection from rotating parts and proper electrical isolation.
- 1.5 Any declarations made by Elta Fans Ltd about product installation and safety, are dependant on the fan equipment being used within installations which themselves meet the requirements of the relevant Standards and Directives of your region.
- 1.6 The fan is designed for use in an ambient temperature of -20°C up to +40°C (SSDD direct drive), -20°C up to +50°C (SSBD belt drive) and up to 95% relative humidity. The fan is not suitable for corrosive or explosive atmospheres.
- 1.7 The installer should provide easy access to the fan to facilitate future maintenance.
- 1.8 The installer should ensure the fan is adequately supported.
- 1.9 This product is not intended for use by persons (including children) with reduced physical, sensory or mental capabilities, or lack of experience and knowledge, unless they have been given supervision or instruction concerning use of the product by a person responsible for their safety. Children should be supervised to ensure that they do not play with the product.

2.0 INSTALLATION

WARNING – The fan must be isolated from the power supply during installation and maintenance. The fan must be earthed in accordance with the local regulations.

- 2.1 Upon receipt, the fan equipment should be visually inspected to check for any damage. Ensure that the impeller is free to rotate.
- 2.2 If there are any queries concerning the fan equipment, Elta Fans Ltd should be contacted prior to the installation.
- 2.3 The fan must be securely mounted in the desired position to suit the application.
The fan is only suitable for horizontal mounting.
- 2.4 Check the details on the motor rating plate to ensure that the correct power supply (voltage, frequency and phase) is available.
An incorrect power supply will lead to permanent damage to the fan motor.
- 2.5 Refer to the appropriate wiring diagram. Ensure that all earth connections are made.
- 2.6 Means for electrical disconnection must be incorporated in the wiring installation in accordance with the relevant wiring and electrical regulations.
- 2.7 Precaution must be taken to locate the exhaust discharge terminal so as to avoid the backflow of gases into the room from the open flue of gas or other fuel burning appliances.

3.0 START-UP

- 3.1 Before power is supplied to the unit, check that the wiring is correct as per the fan connection diagram.
- 3.2 At initial start-up, check that impeller rotation and airflow direction is correct.
- 3.3 Check that the motor amperage draw does not exceed the nameplate rating.

4.0 FAN MAINTENANCE

- 4.1 Inspection of the fan at least once every 12 months is recommended to ensure that the motor, fan blades, and supporting guards, are clean. Any build up of dust and deposits on the blades or guards should be removed using a non-abrasive cleaner.
- 4.2 All fastenings should be checked for tightness. In addition, all rotating items should be checked.
- 4.3 Bearings are of the 'sealed for life' type and will not need a detailed inspection.

5.0 BELT TENSION AND ALIGNMENT

- 5.1 The belt tension and alignment should be checked:
 - When fitting new belts or when installing and starting a fan for the first time.
 - After the first 30 minutes of operation.
 - At least every 6 months.
- 5.2 The pulleys must be checked for correct alignment before checking the belt tension and again after making any adjustments. A straight edge should be placed across the faces of both pulleys to ensure that both shafts and pulleys are parallel and in alignment.
- 5.3 Measure the centre distance between pulleys.
- 5.4 Multiply the pulley centre distance in metres by 16 to obtain the required belt deflection in mm.
- 5.5 Set the required belt deflection on the tension gauge.
- 5.6 With the tension gauge at right angles to the belt and at the mid point between pulleys, apply a force so that the set deflection is achieved.
- 5.7 Check the force applied against the tabulated values below.
- 5.8 Increase the pulley centre distance until the correct force value is obtained.
- 5.9 Run the drive for 30 minutes and re-tension if required.

Belt Section	Force required to deflect belt 16mm per metre of span		
	Small Pulley Dia - mm	Newton - N	Force - kgf
SPZ	67 to 95	10 to 15	1.0 to 1.5
	100 to 140	15 to 20	1.5 to 2.0
SPA	100 to 132	20 to 27	2.0 to 2.7
	140 to 200	28 to 35	2.8 to 3.5

6.0 BELT REPLACEMENT

- 6.1 Worn or damaged belts will require periodic replacement.
- 6.2 Loosen the motor bolts and move the motor towards the fan until the belts can be easily removed by hand without using a tool.
- 6.3 If the drive is fitted with more than one belt, all belts must be replaced simultaneously as a matched set.
- 6.4 Tension and align the drive per Clause 5.0 above, ensuring that all fasteners are tightened.

WARNING – SSDD fans are fitted with an auto-reset thermal contact which switches the fan off in the event of a fault condition.

Once the motor cools down the fan may start unexpectedly.

SSBD fans are fitted with standard metric frame foot mounted motors.

Fuses /circuit breakers are used to provide short circuit protection only. A starter panel with overload protection should be used to protect the motor.

Only a suitably qualified and competent person may carry out maintenance after the electrical supply has been isolated.

FIXED SPEED CONNECTION

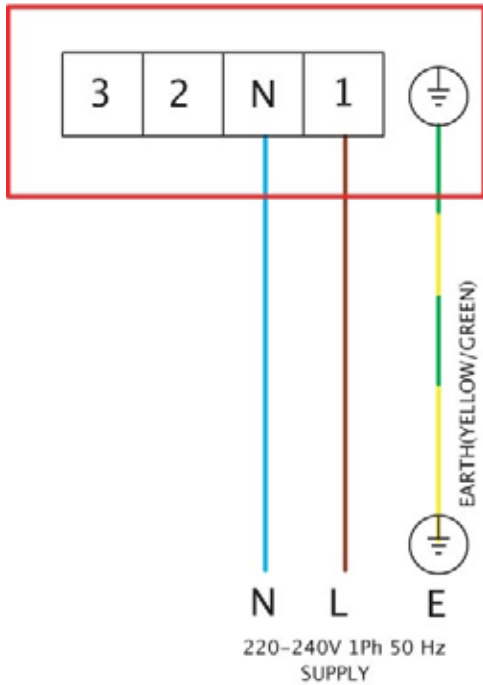

FIXED SPEED CONNECTION

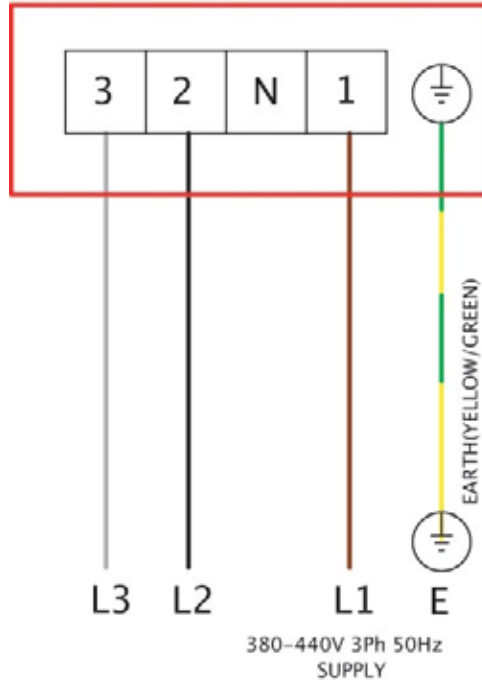

GUARANTEE

Elta Fans Ltd will, free of charge, within a period of 1 year from the date of despatch from their works, repair or at its option replace any goods which are proved to have defects as a result of defective materials or workmanship. The goods **MUST** be returned to Elta Fans Ltd carriage paid for examination.

Elta Fans Ltd

17 Barnes Wallis Road
 Segensworth East Industrial Estate
 Fareham, Hampshire, PO15 5ST, United Kingdom

Visit: eltafans.com

e-mail: mailbox@eltafans.co.uk

Applied Technology: **Tel:** +44(0) 1489 566500

Fax: +44(0) 1489 566555

Building Services: **Tel:** +44(0) 1384 275800

Fax: +44(0) 1384 275810

Export: **Tel:** +44(0) 1489 566500

Fax: +44(0) 1489 566555