



# Skyflow SSF

## Installation and Maintenance Instructions

**THESE INSTRUCTIONS MUST BE READ FULLY BEFORE COMMENCING INSTALLATION**

Code	Supply	FL Amps	Output kW	r/min
SSF25/4-1	230V/1Ph/50Hz	0.90	0.09	1455
SSF31/4-1	230V/1Ph/50Hz	0.90	0.09	1390
SSF35/4-1	230V/1Ph/50Hz	0.90	0.09	1330
SSF40/4-1	230V/1Ph/50Hz	1.80	0.25	1375
SSF45/6-1	230V/1Ph/50Hz	1.05	0.12	850
SSF45/4-1	230V/1Ph/50Hz	1.80	0.25	1300
SSF50/6-1	230V/1Ph/50Hz	1.55	0.18	860
SSF50/4-1	230V/1Ph/50Hz	3.60	0.55	1350
SSF56/6-1	230V/1Ph/50Hz	2.20	0.25	875
SSF56/4-1	230V/1Ph/50Hz	4.90	0.75	1350
SSF63/6-1	230V/1Ph/50Hz	6.00	0.55	850
SSF63/4-1	230V/1Ph/50Hz	7.90	1.1	1310

Code	Supply	FL Amps	Output kW	r/min
SSF31/4-3	400V/3Ph/50Hz	0.50	0.12	1390
SSF35/4-3	400V/3Ph/50Hz	0.50	0.12	1330
SSF40/4-3	400V/3Ph/50Hz	1.40	0.37	1375
SSF45/6-3	400V/3Ph/50Hz	0.68	0.18	850
SSF45/4-3	400V/3Ph/50Hz	1.40	0.37	1300
SSF50/6-3	400V/3Ph/50Hz	0.94	0.25	830
SSF50/4-3	400V/3Ph/50Hz	1.75	0.55	1320
SSF56/6-3	400V/3Ph/50Hz	0.94	0.25	830
SSF56/4-3	400V/3Ph/50Hz	2.00	0.75	1320
SSF63/6-3	400V/3Ph/50Hz	1.90	0.55	850
SSF63/4-3	400V/3Ph/50Hz	4.30	1.5	1320
SSF71/6S-3	400V/3Ph/50Hz	1.50	0.50	720
SSF71/6D-3	400V/3Ph/50Hz	3.40	1.1	880
SSF71/4S-3	400V/3Ph/50Hz	4.30	1.5	1380
SSF80/6S-3	400V/3Ph/50Hz	1.50	0.50	620
SSF80/6D-3	400V/3Ph/50Hz	3.40	1.1	820

Code	A	B	C	D	E	F	G	H	J	K	L	M	N	P	R	Wght kg
SSF25	500	500	310	80	428	240	428	175	542	380	340	440	50	-	-	12
SSF31/35	710	684	365	85	610	240	636	250	750	500	460	610	75	-	-	19
SSF40/45	800	784	445	90	730	250	756	300	870	600	550	700	75	-	-	37
SSF50/56	960	934	510	100	860	250	886	350	1000	745	700	850	75	-	-	53
SSF63/71	1230	1054	590	105	1000	250	1026	435	1140	870	830	980	75	-	-	62
SSF80	1400	1174	670	100	1076	270	1076	470	1190	-	950	1100	75	406	990	64

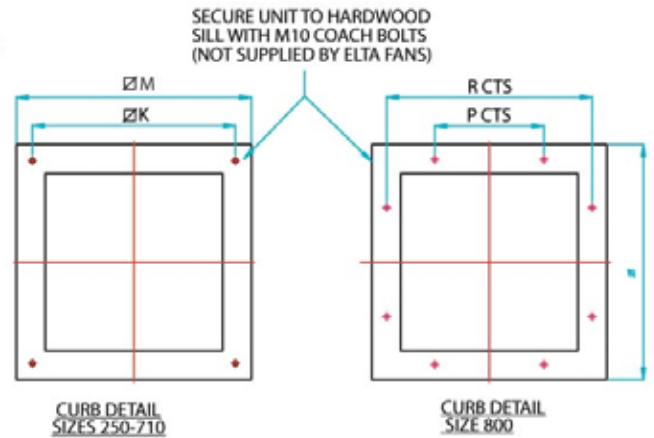
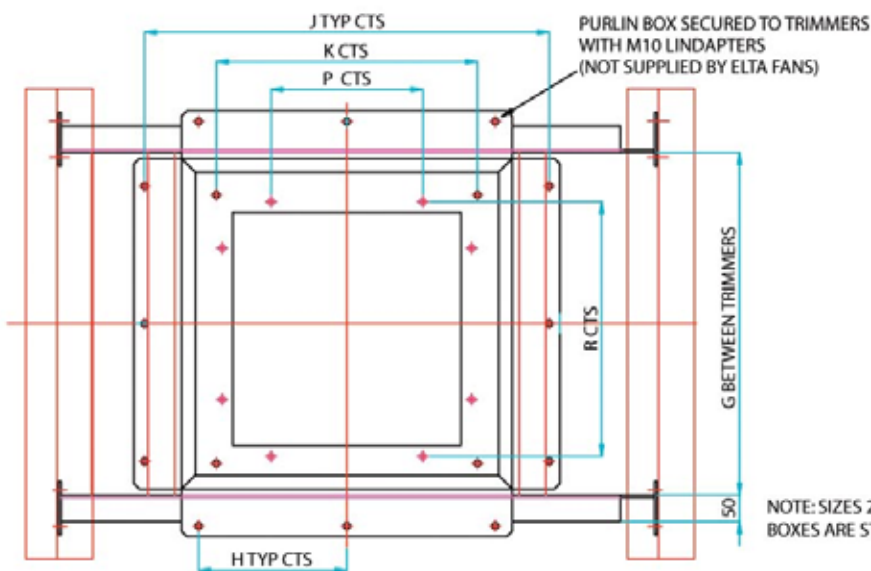
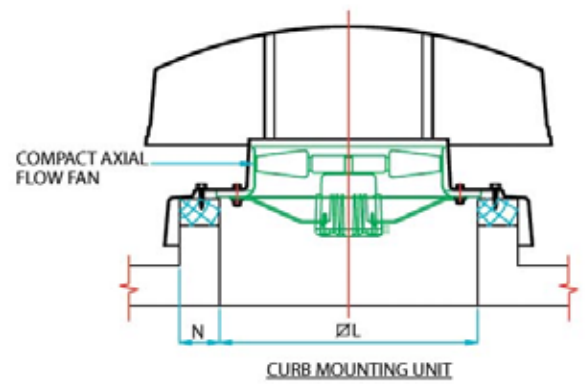
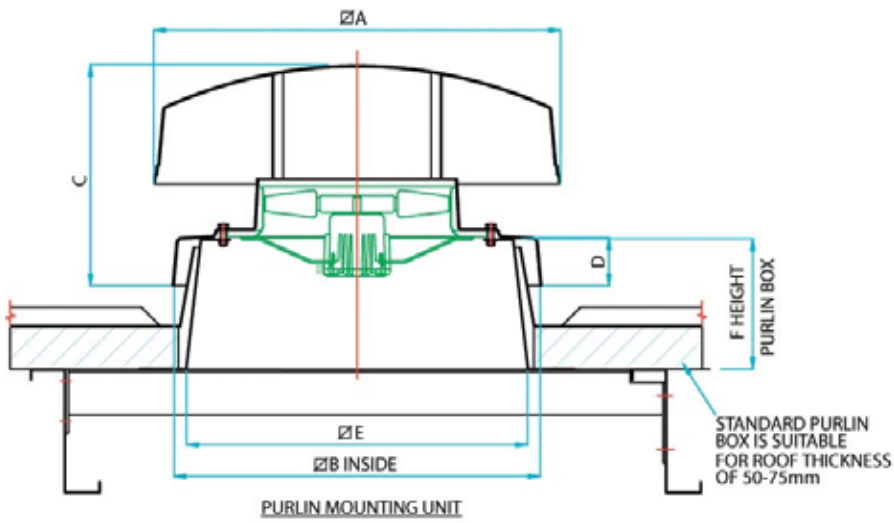

NOTE: SIZES 250 & 800 PURLIN BOXES ARE STRAIGHT SIDED

## 1.0 GENERAL

- 1.1 It is important these Installation and Maintenance Instructions are fully adhered to.
- 1.2 Full details of the unit supplied are shown on the product nameplate. If in doubt about any detail contact Elta Fans Ltd or its agents for clarification.
- 1.3 All electrical installation must be carried out by suitably qualified and competent personnel in accordance with all current statutory requirements.
- 1.4 These instructions cover only the Elta Fans Ltd product and do not include the supply or installation of any safety equipment that may be required e.g. adequate guarding or protection from rotating parts and proper electrical isolation.
- 1.5 Any declarations made by Elta Fans Ltd about product installation and safety, are dependant on the fan equipment being used within installations which themselves meet the requirements of the relevant Standards and Directives of your region.
- 1.6 The fan is designed for use in an ambient temperature of -20°C up to +70°C fixed speed, -20°C up to +50°C when used with a speed controller and up to 95% relative humidity. The fan is not suitable for corrosive or explosive atmospheres.
- 1.7 The installer should provide easy access to the fan to facilitate future maintenance.
- 1.8 The installer should ensure the fan is adequately supported.
- 1.9 This product is not intended for use by persons (including children) with reduced physical, sensory or mental capabilities, or lack of experience and knowledge, unless they have been given supervision or instruction concerning use of the product by a person responsible for their safety. Children should be supervised to ensure that they do not play with the product.

## 2.0 INSTALLATION

**WARNING – The fan must be isolated from the power supply during installation and maintenance. The fan must be earthed in accordance with the local regulations.**

- 2.1 Upon receipt, the fan equipment should be visually inspected to check for any damage. Ensure that the impeller is free to rotate.
- 2.2 If there are any queries concerning the fan equipment, Elta Fans Ltd should be contacted prior to the installation.
- 2.3 The fan must be securely mounted in the desired position to suit the application. The fan can be mounted on flat or inclined roofs with a maximum pitch angle of 35°.
- 2.4 **Assembly:** Invert the GRP cowl and base assembly taking care not to damage the surface of the cowl. Place the fan unit onto the base, lining up the four corner holes of the mounting plate with the pre-drilled holes in the base. Do not remove the plugs from any unused holes. Secure the fan to the base ensuring that the red fibre washers are correctly positioned between the underside of the bolt head and the outer surface of the base.

DO NOT OVERTIGHTEN THE BOLTS AS THIS MAY DAMAGE THE BASE.

- 2.5 **Backdraught shutters:** Backdraught shutters can be supplied as a factory fitted option, but when purchased for retro fitting the following procedure should be followed:
  - Remove the cowl taking note of its position, as it must be refitted in exactly the same position.
  - Note: The cowl support arms are provided with captive fixings.
  - Place the shutter halves together and feed the aluminium spindle through the holes forming the hinge.
  - Slide a black plastic spacer onto each spindle end ensuring that the whole shutter assembly is equally spaced and the shutter blades are free to move.
  - Slide one end of the spindle through the lower hole in the cowl support arm and by 'springing' the opposite arm outward, insert the other end of the spindle into the lower hole.
  - Fit one spring clip to each spindle end and check to make sure that the shutter blades move freely and also engage correctly onto the base upstand.
  - Refit the cowl taking care not to over tighten the bolts.
- 2.6 **Curb mounting:** Position the assembled roof unit onto the curb and secure to the timber sill with M10 coach bolts (not supplied by Elta Fans), ensuring that fibre washers are positioned under each

bolt head. It is advisable to drill pilot holes prior to fitting the bolts to prevent splitting the timber curb.

DO NOT OVERTIGHTEN THE BOLTS AS THIS MAY DAMAGE THE BASE.

### 2.7 **Purlin mounting:**

- Purlin trimmers: - should be bolted to the vertical flange of the purlin member taking care to align with the roof opening.
- Purlin box: - position onto trimmers and fit M10 type 'A' short tail lindaptors (not supplied by Elta Fans) into holes in the bottom flanges. Do not tighten nuts at this stage.
- Soaker sheets: - slip the soaker sheet over the purlin box and fix and seal to the roof sheeting. Align the purlin box with the soaker sheet and tighten the lindaptor nuts.
- Position the roof unit into the purlin box and insert M10 bolts into the four corner holes and into the purlin box captive fixings ensuring that fibre washers are positioned under the bolt heads.

DO NOT OVERTIGHTEN THE BOLTS AS THIS MAY DAMAGE THE BASE .

2.8 Check the details on the motor rating plate to ensure that the correct power supply (voltage, frequency and phase) is available.

An incorrect power supply will lead to permanent damage to the fan motor.

2.9 Refer to the appropriate wiring diagram. Ensure that all earth connections are made.

2.10 Means for electrical disconnection must be incorporated in the wiring installation in accordance with the relevant wiring and electrical regulations.

2.11 Precaution must be taken to locate the exhaust discharge terminal so as to avoid the backflow of gases into the room from the open flue of gas or other fuel burning appliances.

## 3.0 **START-UP**

3.1 Before power is supplied to the unit, check that the wiring is correct as per the fan connection diagram.

3.2 At initial start-up, check that impeller rotation and airflow direction is correct.

3.3 Check that the motor amperage draw does not exceed the nameplate rating.

## 4.0 **FAN MAINTENANCE**

4.1 Inspection of the fan at least once every 12 months is recommended to ensure that the motor, fan blades, and supporting guards, are clean. Any build up of dust and deposits on the blades or guards should be removed using a non-abrasive cleaner.

4.2 All fastenings should be checked for tightness. In addition, all rotating items should be checked.

4.3 Bearings are of the 'sealed for life' type and will not need a detailed inspection.

**WARNING – This fan is fitted with an auto-reset thermal contact which switches the fan off in the event of a fault condition.**

**Once the motor cools down the fan may start unexpectedly.**

**Only a suitably qualified and competent person may carry out maintenance after the electrical supply has been isolated.**

# WIRING

## FIXED SPEED CONNECTION

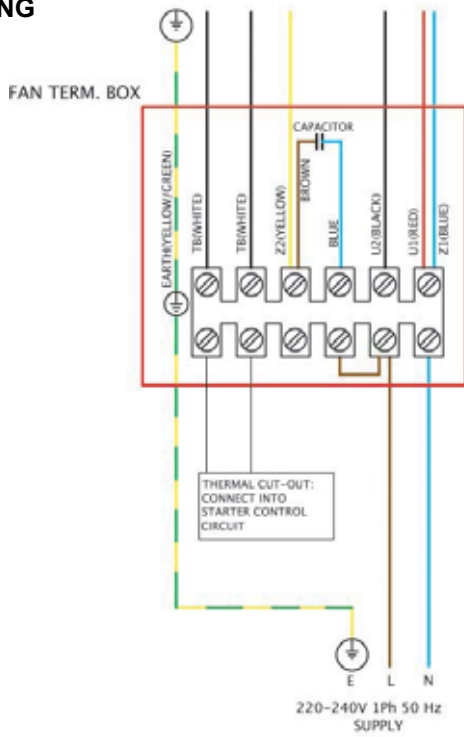

## VARIABLE SPEED CONNECTION CONTROLLER TYPES: 149-EL31TK 149-EL61TK

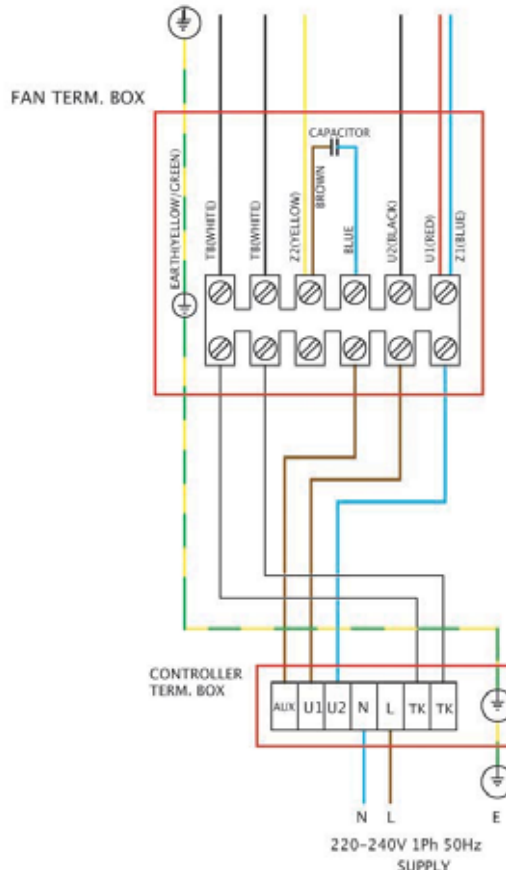

## VARIABLE SPEED CONNECTION CONTROLLER TYPES: 149-TC12 149-TC14 149-TC18 149-TC110

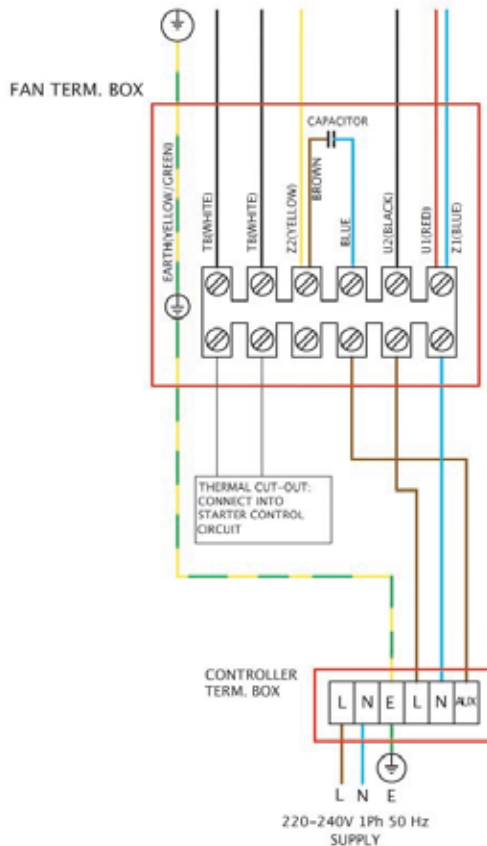

## FIXED SPEED CONNECTION

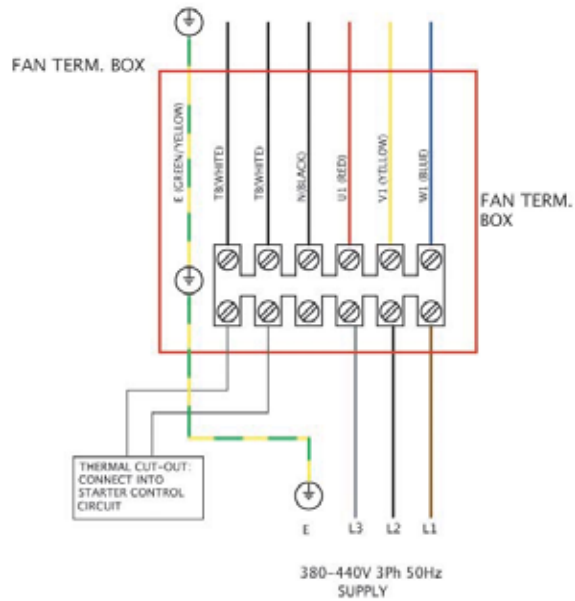

**VARIABLE SPEED CONNECTION  
CONTROLLER TYPE: 149-TC3\*\***

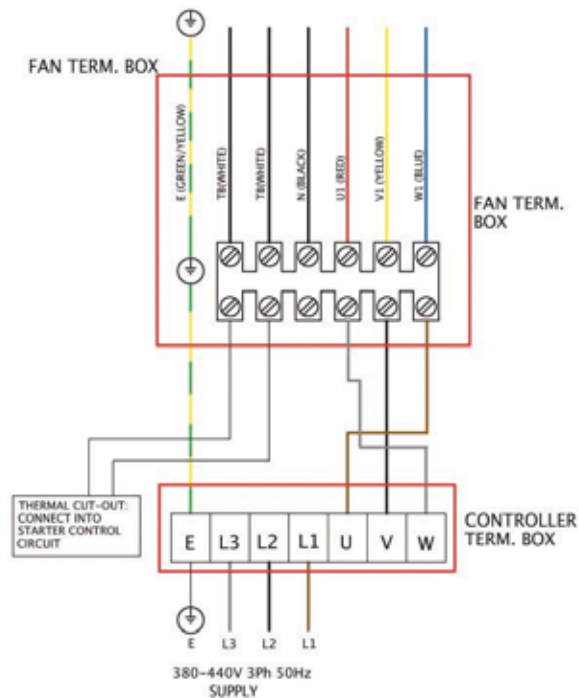

**GUARANTEE**

Elta Fans Ltd will, free of charge, within a period of 1 year from the date of despatch from their works, repair or at its option replace any goods which are proved to have defects as a result of defective materials or workmanship. The goods **MUST** be returned to Elta Fans Ltd carriage paid for examination.

**Elta Fans Ltd**

17 Barnes Wallis Road  
Segensworth East Industrial Estate  
Fareham, Hampshire, PO15 5ST, United Kingdom

**Visit:** eltafans.com

**e-mail:** mailbox@eltafans.co.uk

**Applied Technology:**

**Tel:** +44(0) 1489 566500

**Fax:** +44(0) 1489 566555

**Building Services:**

**Tel:** +44(0) 1384 275800

**Fax:** +44(0) 1384 275810

**Export:**

**Tel:** +44(0) 1489 566500

**Fax:** +44(0) 1489 566555