

MINIFLOW
SAMF



Duct Mounted **Axial Fans**

Miniflow SAMF – Cased Axial Features & Benefits



The cased axial Miniflow SAMF is a duct mounted axial fan with a lightweight, yet robust design. Specifically developed as a cost effective alternative to in-line centrifugal fans, it provides powerful airflow at lower pressures for applications ranging from domestic to commercial ventilation.

- 4 standard sizes from 150mm to 315mm.
- Air volume flow rates of up to 0.639 m³/sec.
- Static pressures of up to 175 Pa.
- External rotor motors.
- Motors are IP44 protected and Class 'B' Insulation.
- Ambient operating temperatures of up to 50° C.
- Easy to install.
- Fully speed controllable.
- Robust steel casings.
- Extensive stock range available.

Features & Benefits

Material strength – Casings provide a long lasting construction, manufactured from galvanised steel, with a high quality powder coated finish after manufacture on all models except the SAMF150/2-2 which has a die cast aluminium housing.

External rotor motor – These are high quality motors and maintenance free with sealed for life ball bearings, which means the fan can be mounted at any angle.

Impeller design – These are aerodynamically designed by combining the impeller with the rotor of the external rotor motor. The motor and impeller is balanced to quality class G6.3.

Speed controllable – Each fan is fully speed controllable with an electronic controller, which means airflow can be altered to suit site conditions.

Safety – All motors are fitted with integral 'Thermal overload protection' preventing the motor from overheating, except the SAMF 150/2-2 which is impedance protected.

Ease of installation – Lightweight design of the SAMF ensures a swift, easy to install product, whilst spigot inlet & outlet connections allow ease of installation for ductwork system fitting. A pre-wired terminal box is also fitted which is external to the casing.

Flexibility – The SAMF can be used where there are long duct runs to boost extraction.

Mounting arrangement – Suitable for duct mounting at any angle.

Full accessory range – Speed controllers, anti-vibration mounts, silencers, non return dampers, flexible connectors, mounting brackets and fast clamps.

Tested to the very latest standards – SAMF units are tested to ISO 5801:1997 (airside performance) and to BS 848 Pt 2:1985 (sound performance) at Elta Fans own test facility, meaning accurate, up to date information on performance and noise data that can be relied upon.

Quality assurance – All units are designed and manufactured with procedures as defined in BS EN ISO 9001: 2000.

Warranty – Each SAMF has a 12 month warranty.

Applications

Ideally suited for small commercial premises and kitchens where there is not an outside wall to terminate a wall fan.

Miniflow SAMF - Cased Axial

Dimensional Data



AXIAL FLOW

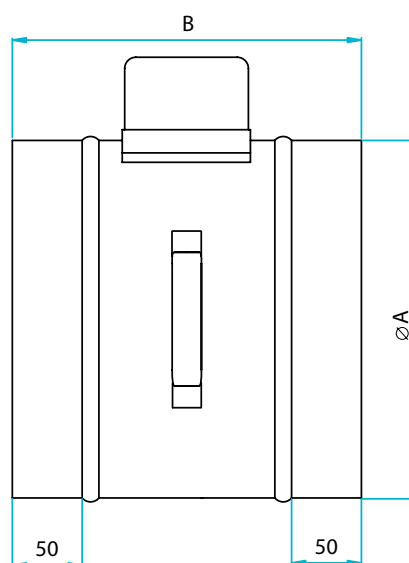
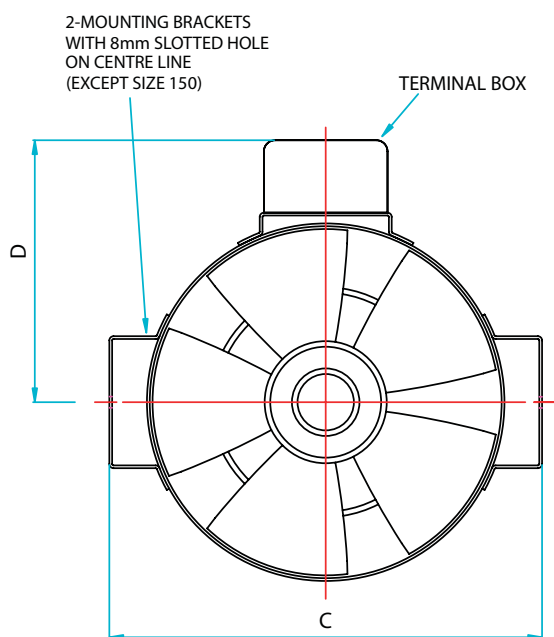

Product Code	A	B	C	D	Weight kg
SAMF150/2	147	165	-	-	1.5
SAMF200/4	206	250	236	164	3.5
SAMF200/2	206	250	236	164	3.5
SAMF250/4	260	250	296	190	4.0
SAMF250/2	260	250	296	190	4.0
SAMF315/4	311	250	346	219	4.8
SAMF315/2	311	250	346	219	4.8

Accessories

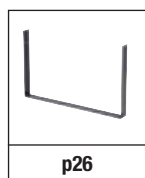

Miniflow SAMF - Cased Axial Performance & Electrical Data



SINGLE Phase - 220V-240V / 50Hz

Product Code	Speed r/min	Airflow m ³ /s @ Static Pressure Pa.								Motor Electrical Data		A.V. Mounts	Speed Control	dBA @ 3m
		0	25	50	75	100	125	150	175	FLC Amps	Input Watts			
SAMF150/2-2	2760	0.110	0.084	0.063	0.044	0.022				0.25	46	S1B	EL31	43
SAMF200/4-2	1440	0.144	0.093	0.053	0.017					0.13	30	S1B	EL31	37
SAMF200/2-2	2580	0.238	0.208	0.170	0.135	0.107	0.085			0.30	60	S1B	EL31	52
SAMF250/4-2	1380	0.279	0.230	0.151	0.079					0.21	50	S1B	EL31	40
SAMF250/2-2	2520	0.420	0.382	0.347	0.309	0.264	0.210	0.151		0.54	120	S1B	EL31	49
SAMF315/4-2	1320	0.555	0.441	0.280	0.161	0.081				0.32	70	S1B	EL31	47
SAMF315/2-2	2460	0.639	0.621	0.592	0.530	0.440	0.364	0.267	0.209	0.71	160	S1B	EL31	62

Sound levels are average spherical free field values at 50% peak pressure for comparative purposes only.

Silencer Data

Product Code	dBA Attenuation			
	300L	600L	900L	1200L
SAMF150/2-2	-15	-21	-24	-27
SAMF200/4-2	-11	-16	-20	-23
SAMF200/2-2	-13	-18	-22	-25
SAMF250/4-2	-11	-15	-18	-20
SAMF250/2-2	-11	-16	-18	-21
SAMF315/4-2	-12	-15	-18	-21
SAMF315/2-2	-14	-18	-21	-23

Miniflow uses spigotted silencers.

Miniflow SAMF - Cased Axial

Sound Data



SAMF- SINGLE Phase

Product Code	63Hz	125Hz	250Hz	500Hz	1kHz	2kHz	4kHz	8kHz	dBA @ 3m
SAMF150/2-2	49	51	59	56	58	58	56	48	43
SAMF200/2-2	68	69	68	67	69	66	60	49	52
SAMF250/2-2	64	69	67	67	65	60	60	51	49
SAMF315/2-2	63	66	74	76	80	75	71	65	62
SAMF200/4-2	60	60	54	56	54	49	40	30	37
SAMF250/4-2	63	64	57	57	57	54	47	37	40
SAMF315/4-2	60	64	64	61	64	62	55	46	47

Miniflow SAMF - Cased Axial

Performance Curves



2 Pole 1Ph Range

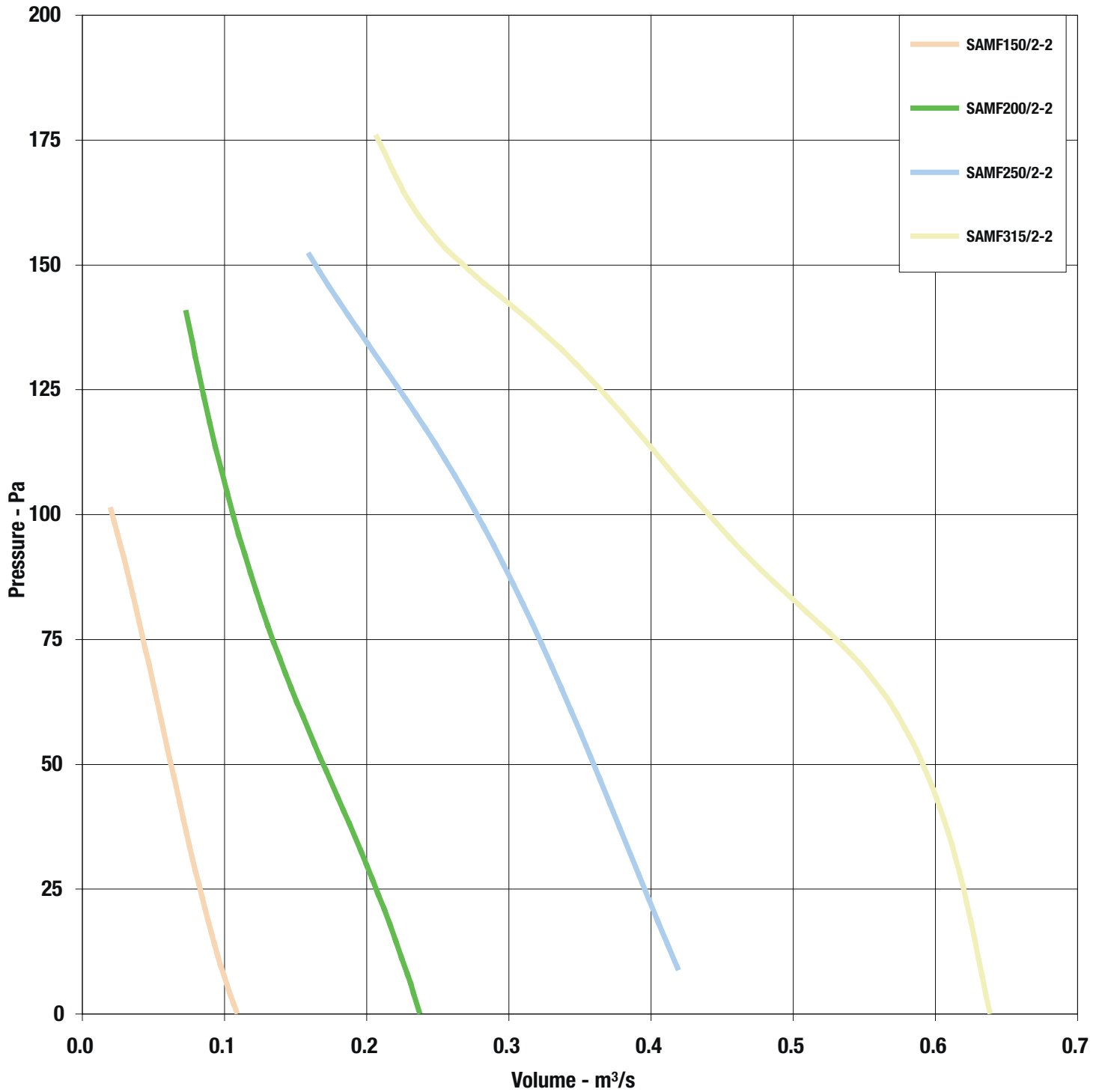

Miniflow SAMF - Cased Axial

Performance Curves



4 Pole 1Ph Range

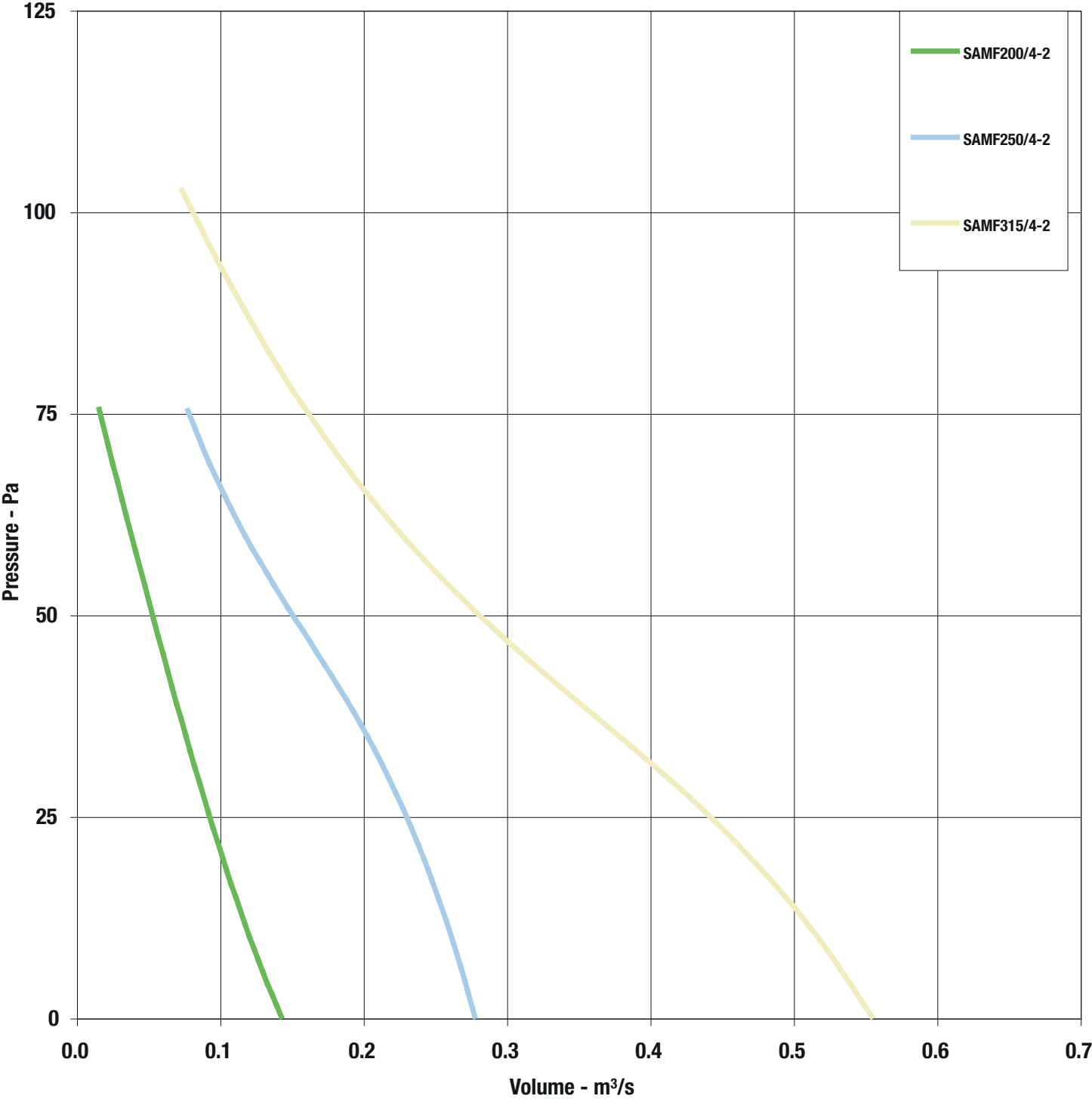

Miniflow SAMF - Cased Axial Accessories



AXIAL FLOW

Flexible Connectors

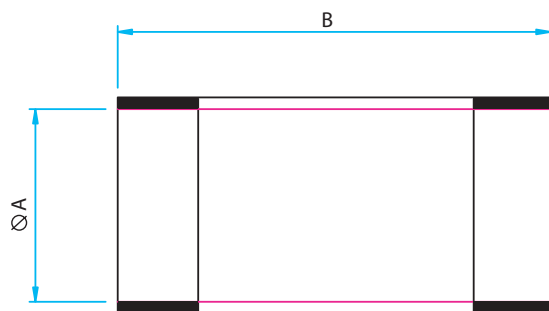

- Fix directly onto spigot
- Provides flexible connection between fan and accessory or duct
- PVC coated polyester with galvanised sheet steel

Product Code	Fan Size	A	B	Weight kg
063-0150-SAMF	150	147	200	0.15
063-0200-SAMF	200	206	200	0.18
063-0250-SAMF	250	260	200	0.21
063-0315-SAMF	315	311	200	0.25

Mounting Brackets

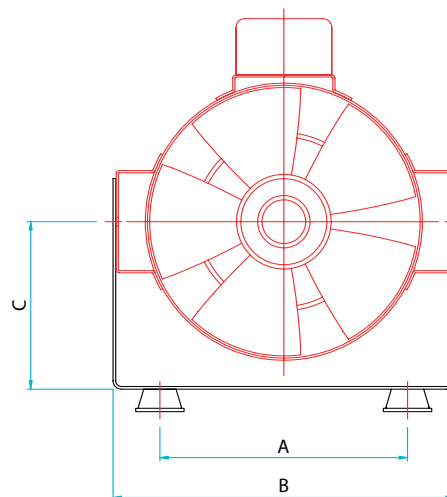

- Bracket to match fan
- Suitable for use as a hanging bracket

Product Code	Fan Size	A	B	C	Weight kg
060A-SAMF200-MB	200	184	254	131	0.46
060A-SAMF250-MB	250	232	312	156	0.48
060A-SAMF315-MB	315	287	366	181	0.56

Anti-Vibration Mounts

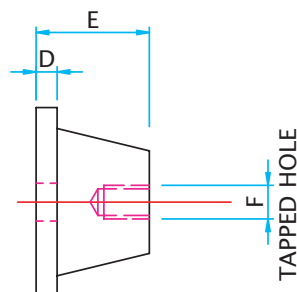
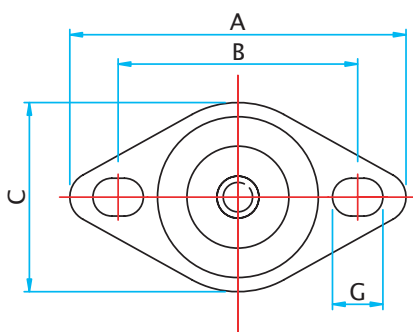

- Fit directly to mounting feet
- Rubber with steel insert
- Supplied as set of 2, complete with fixings

Product Code	A	B	C	D	E	F	G	Weight kg
062-S1B	64	50	43	5.5	20	M6	Ø7	0.040

Miniflow SAMF - Cased Axial Accessories



Silencers

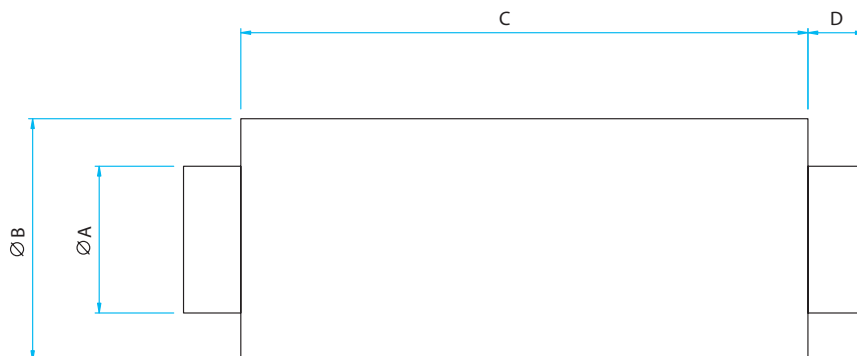

- For information on silencers and an explanation of the data, see p74
- Pre-galvanised sheet steel with perforated steel lining
- Infill of glass tissue faced high density mineral wool
- For saturated or other special applications please refer to Elta

Product Code	Fan Size	A	B	C 1	C 2	C 3	C 4	D	Weight kg			
									1	2	3	4
068-0150-JF*	150	148	255	300	600	900	1200	40	3.4	6.1	8.9	11.6
068-0200-JF*	200	198	305						4.2	7.6	11.0	14.5
068-0250-JF*	250	248	355						5.0	9.1	13.2	17.3
068-0315-JF*	315	313	420						6.1	11.1	16.1	21.0

* Add 1, 2, 3, 4 depending on length required.

Fast Clamps

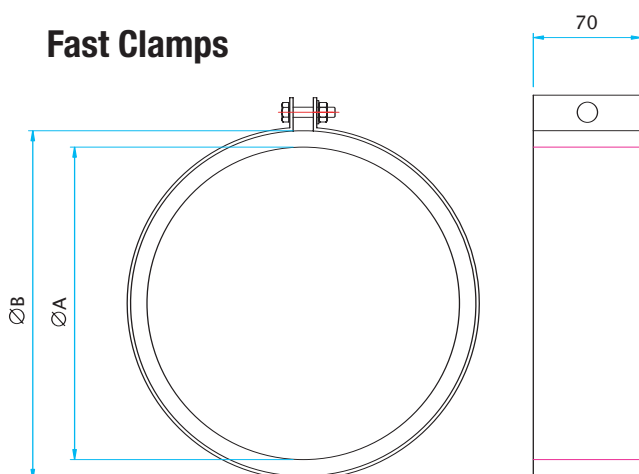

- For quick connection of spigotted fans to circular duct or accessories
- Galvanised steel circular duct clamp with foam lining

Product Code	Fan Size	A	B	Weight kg
018-150-CLAMP	150	142	166	0.33
018-200-CLAMP	200	192	216	0.42
018-250-CLAMP	250	242	266	0.49
018-315-CLAMP	315	307	331	0.59

Non Return Dampers

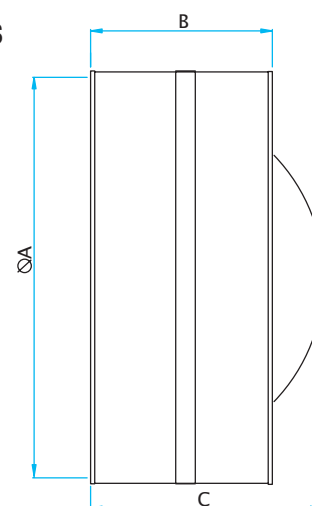

- Prevents reverse flow of air when fan not operating
- Galvanised sheet steel case
- Spring operated aluminium sheet blades

Product Code	Fan Dia. A	B	C	Weight kg
018-150-DAMPER	150	90	110	0.3
018-200-DAMPER	200	125	150	0.6
018-250-DAMPER	250	125	190	0.6
018-315-DAMPER	315	125	210	1.3



Elta Fans Ltd - Applied Technology

17 Barnes Wallis Road,
Segensworth East Industrial Estate,
Fareham, Hampshire, P015 5ST, United Kingdom.

Visit: eltafans.com

e-mail: mailbox@eltafans.co.uk

Applied Technology:

Tel: +44 (0) 1489 566500

Fax: +44 (0) 1489 566555

Building Services:

Tel: +44 (0) 1384 275800

Fax: +44 (0) 1384 275810

Export:

Tel: +44 (0) 1489 566500

Fax: +44 (0) 1489 566555