

SERIES MN

High Induction
Multi Nozzle
Diffusers

PUBLICATION

DIFFUSERS 17

MAY 2008



Features

- Modern ergonomic design and styling.
- High induction effect.
- High air change rate capabilities.
- Versatile multi-directional control.
- Lightweight design and construction.
- Compatible with modern ceiling designs.
- Cost effective design solution



GILBERTS



SERIES MN

Introduction

With the Series MN Gilberts introduce a further bold development on the high performance diffuser theme. Moving away from traditional louvred face design the Series MN incorporates the latest in modern design and styling in a high performance package which provides the combination of both aesthetics and performance for the demanding projects of today. The unit features a patterned array of unique, high induction nozzles that have been designed to provide a smooth, quiet, rapidly entrained airflow with an added induction effect on room air that allows a high volume of air to be delivered cleanly and effectively from a compact design. This enables system designers to

provide a lower cost air distribution solution as compared to traditional diffuser designs. All of the nozzles can be individually rotated enabling the device to provide a wide variety of horizontal air distribution patterns and, with the nozzles simple push clip fitting into a steel fascia, the opportunities are there to customise designs and patterns to suit individual clients and installations. Alternative border styles are also available to match up with current ceiling grid styles.

Available Range:

- TYPE MN- A** - Standard multi nozzle diffuser with 32mm flange border suitable for plaster ceiling applications.
- TYPE MN- B** - Multi nozzle ceiling diffuser with clip in ceiling border edge detail.
- TYPE MN- C** - Multi nozzle ceiling diffuser with borderless, clean edged frame suitable for lay in ceiling grid application.
- TYPE MN- D** - Multi nozzle diffuser with stepped flange border frame suitable for tegular ceiling grid application.

Further adaption on these border frame platforms allow the integration of the Series MN into almost any ceiling type, specification or design. For volume control quadrant or cord operated flap type dampers or iris type dampers can be fitted to the side or top entry plenum inlet.

Standard finish for the MN fascia is Polyester Powder White (RAL 9010 20% GLOSS) with the nozzles formed in the matching colour. Other colours are available dependant on economical quantity.

Features

- Modern ergonomic design and styling.
- High induction effect.
- High air change rate capabilities.
- Versatile multi-directional control.
- Lightweight design and construction.
- Compatible with modern ceiling designs.
- Cost effective design solution



Nozzle Induction Effect

Nozzle Flow Diagram Top Elevation

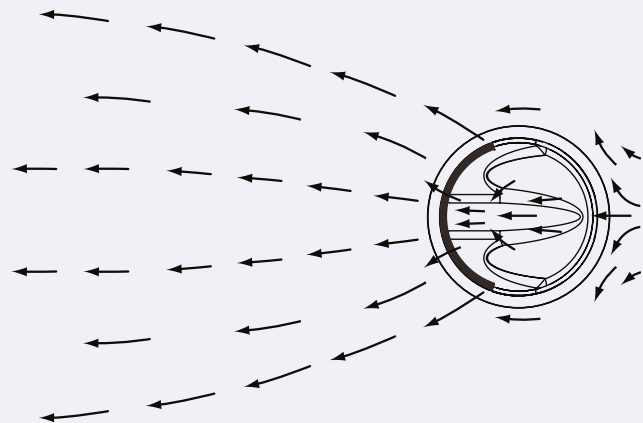

Side Elevation

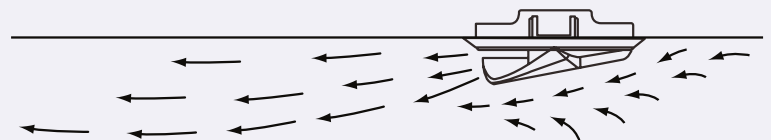

The smaller the arrow the lower the flow magnitude

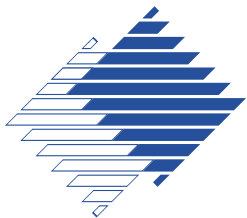

SERIES MN

Selection Procedure

Reference (A) Evenly Spread Layouts

- 1) Try if possible to construct in plan an imaginary square ceiling grid. This will enable the designer to position each diffuser at each square centre so that the distribution is even in all directions
- 2) Total volume of air is then divided by the number of outlets and the volume per diffuser is established.
- 3) The performance charts should then be used to select the size and type of diffuser based upon the volume and throw requirements. For high ceiling applications an over blow situation can be acceptable.
- 4) Check pressure loss NC levels from design chart to confirm acceptability.

Example

Take a 20m x 20m open office area with a total required volume to be supplied of 2.72m³/s. Divide this area up in to 16 equally spaced segments each measuring 5m x 5m and position a nozzle diffuser in the centre of these imaginary grids. If we divide the total volume by 16 diffusers then this will equate to 170 l/s per diffuser. From the chart for a size 600 in a horizontal distribution we can select a unit handling 170 l/s which gives a noise level of NC30 and a static pressure drop of 13Pa. Throws in isothermal conditions are between 0.8m and 2.0m very similar whether for heating or cooling.

This should be an acceptable selection for this area.

Reference (B) Specific Directional Airflow Requirements

- 1) If the diffuser layout becomes restricted and specific directional throws are required for each diffuser, then nozzles can be rotated to obtain 1,2,3 and 4 way characteristics.
- 2) Position these types of diffuser as necessary and then establish the correct directional airflow requirements for each position.
- 3) Again establish the airflow requirements per diffuser and from the data tables check throw requirements, noise levels and pressure drops.
- 4) Note the multiplication factors that must be applied for throws if using directional characteristics. Throws given in all sizing tables are for nozzle action arranged in a swirl pattern.

Example

If we took the previous example with a diffuser handling 170 l/s and again a size of 600 square but required it to operate in a two way distribution pattern then we would see from the multiplication factors for throws that an increase of three times the original swirl characteristics would apply. This would give throws in the order of approximately 6m in both directions. Noise levels and pressure drops however would be the same as the the previous example (i.e. NC30 with a pressure drop of 13Pa). The coverage and diffuser positioning for this 2 way AIR DISTRIBUTION differs therefore from the previous evenly spread layout.

The MN series multi nozzle diffusers provide ultimate flexibility in directional air control. Standard distribution patterns include a swirl pattern as well as 4 way, 3, way, 2 way, 1 way and even full vertical. Indeed with all nozzles individually adjustable further permutations are available and nozzles can also be specially arranged in many different patterns. Test data is included for the standard following configurations....

Air Distribution Patterns

Swirl Distribution

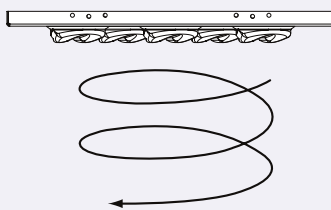
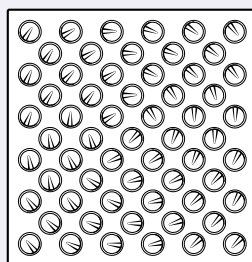

The standard factory set air distribution pattern is the swirl effect. Swirl air distribution is highly efficient allowing the introduction of higher air volumes than conventional diffusers taking advantage of its rapid intermixing and entrainment abilities. The swirl pattern also makes the most effective use of the nozzles design feature with a secondary induction effect of room air. Nozzle positioning for full swirl effect is illustrated on the left. Nozzles can be adjusted for other air patterns as shown on this and the following page.

Vertical Distribution

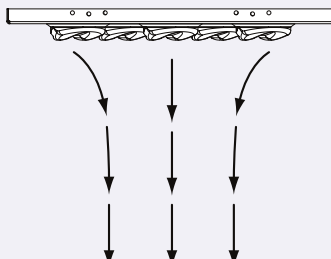
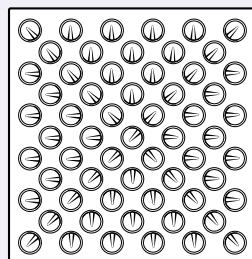

As well as the swirl pattern and various horizontal distribution options the nozzles can be adjusted and set to provide total or partial vertical air discharge. The nozzle pattern settings (as shown) will provide a total vertical air distribution pattern where required. Throws for this configuration for the various sizes and volumes are provided in the sizing charts at a selection of alternative temperature differentials



SERIES MN

Air Patterns

Swirl Distribution

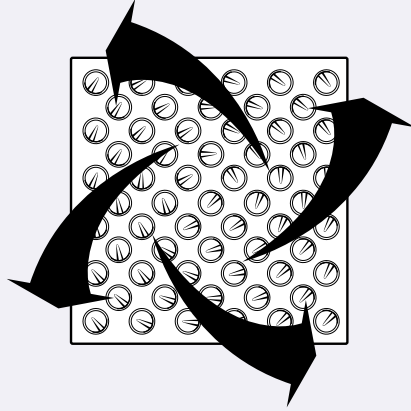

4 Way

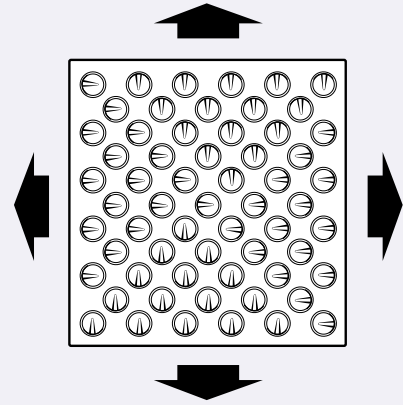

3 Way

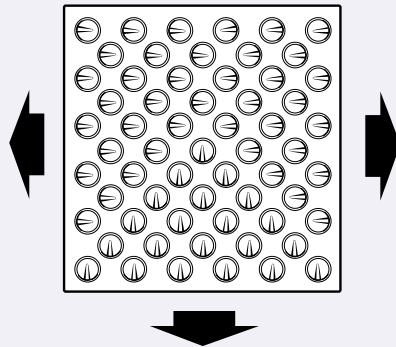

2 Way

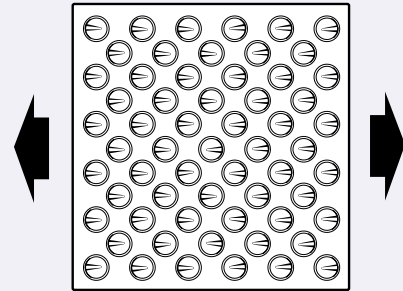

1 Way

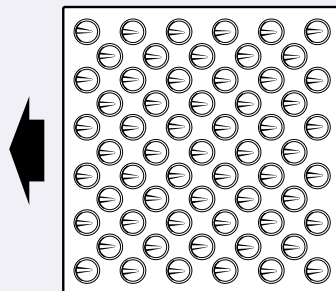

Vertical Distribution

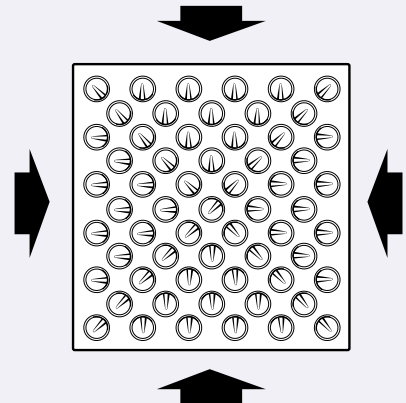



SERIES MN

Type MN - A

Diffuser

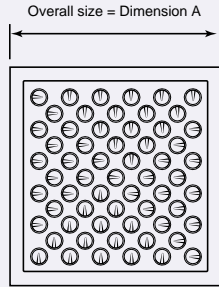
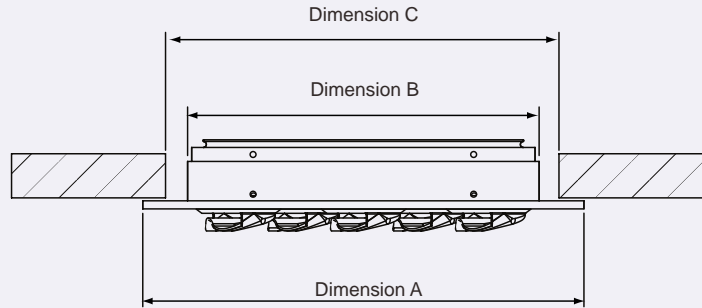

MNA			
SIZE	DIM A	DIM B	DIM C
300	364	304	318
400	464	404	418
500	564	504	518
600	664	604	618

Diffuser with Side Entry Box

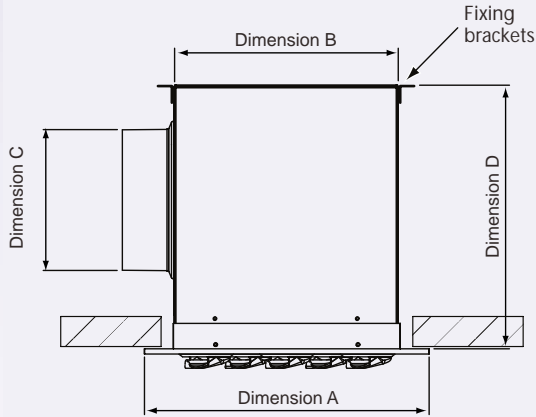

MNA - SEB				
SIZE	DIM A	DIM B	DIM C	DIM D
300	364	299	200	300
400	464	399	250	350
500	564	499	315	415
600	664	599	350	450

Diffuser with Top Connection Box

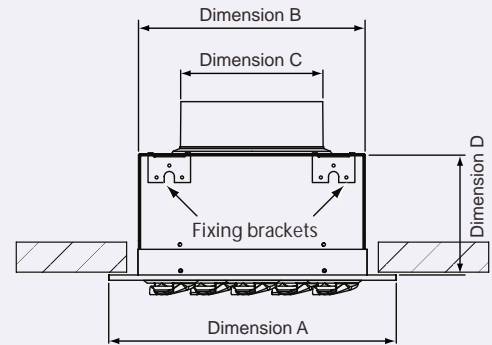

MNA - TCB				
SIZE	DIM A	DIM B	DIM C	DIM D
300	364	299	200	150
400	464	399	250	200
500	564	499	315	250
600	664	599	350	300

Note: All diffusers should be independently supported. Standard fixing for all units is via drop rod (by others) to either elongated the slots in the plenum hanging brackets or the dedicated holes in the diffuser frame.



SERIES MN

TYPE MN - B

Diffuser

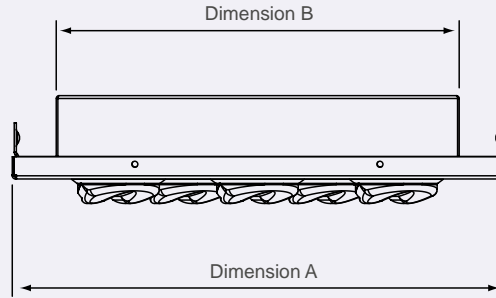

Overall size = Dimension A

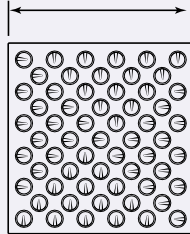

MNB			
SIZE	DIM A	DIM B	DIM C
300	499	445	500
	599	545	600
400	499	445	500
	599	545	600
500	499	445	500
	599	545	600
600	599	545	600

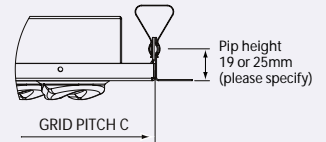

Diffuser with Side Entry Box

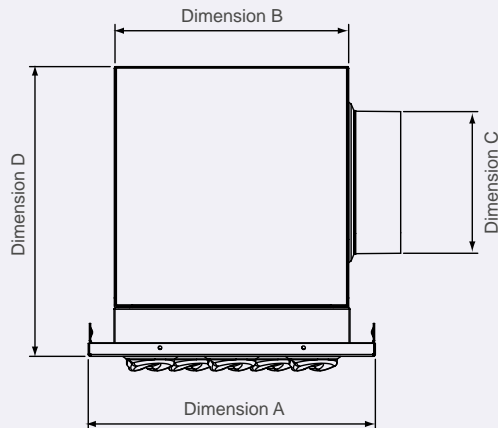

MNB - SEB				
SIZE	DIM A	DIM B	DIM C	DIM D
300	499	445	200	300
	599	545		
400	499	445	250	350
	599	545		
500	499	445	315	415
	599	545		
600	599	545	350	450

Diffuser with Top Connection Box

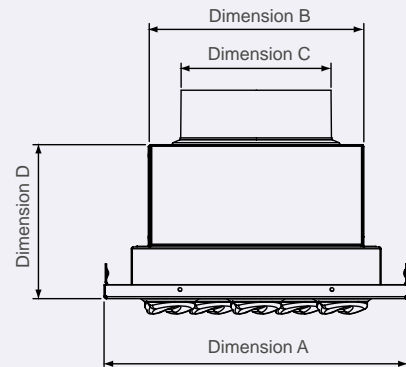

MNB - TCB				
SIZE	DIM A	DIM B	DIM C	DIM D
300	499	445	200	150
	599	545		
400	499	445	250	200
	599	545		
500	499	445	315	250
	599	545		
600	599	545	350	300

Note: All diffusers should be independently supported. Standard fixing for all units is via drop rod (by others) to either elongated slots in the plenum hanging brackets or the dedicated holes in the diffuser frame.

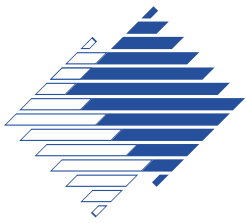

TYPE MN - C

Diffuser

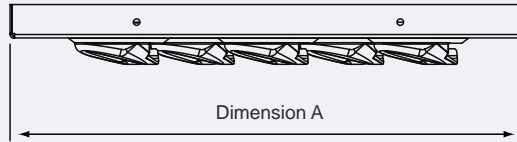

MNC		
SIZE	DIM A	DIM B
300	494	500
	594	600
400	494	500
	594	600
500	494	500
	594	600
600	594	600

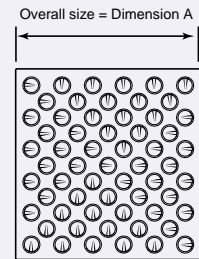
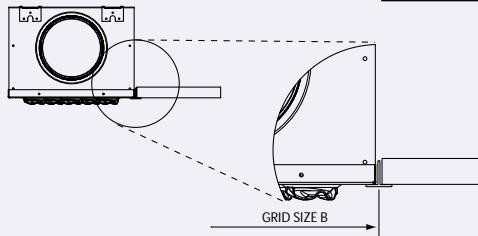

Diffuser with Side Entry Box

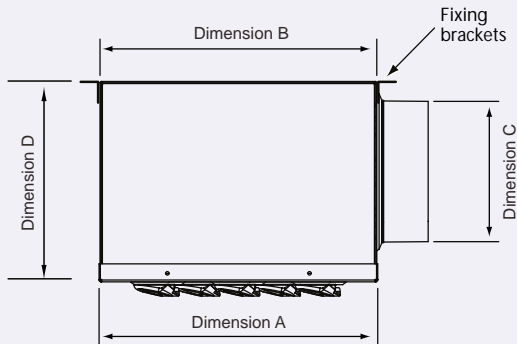

MNC - SEB				
SIZE	DIM A	DIM B	DIM C	DIM D
300	494	492	200	300
	594	592		
400	494	492	250	350
	594	592		
500	494	492	315	415
	594	592		
600	594	592	350	450

Diffuser with Top Connection Box

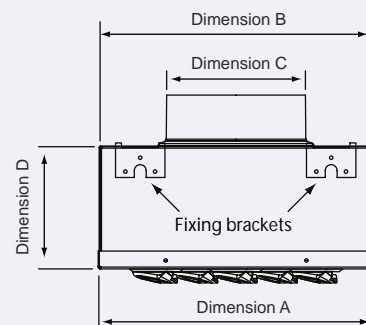

MNC - TCB				
SIZE	DIM A	DIM B	DIM C	DIM D
300	494	492	200	150
	594	592		
400	494	492	250	200
	594	592		
500	494	492	315	250
	594	592		
600	594	592	350	300

Note: All diffusers should be independently supported. Standard fixing for all units is via drop rod (by others) to either elongated the slots in the plenum hanging brackets or the dedicated holes in the diffuser frame.



SERIES MN

TYPE MN - D

Diffuser

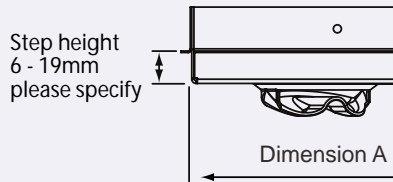
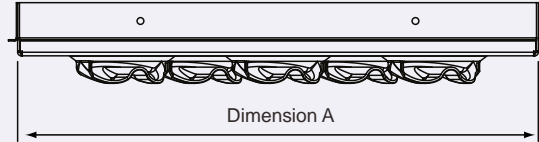

MND	
SIZE	DIM A
300	474
	484
	574
	584
400	474
	484
	574
	584
500	474
	484
	574
	584
600	574
	584

Overall size = Dimension A + 10mm

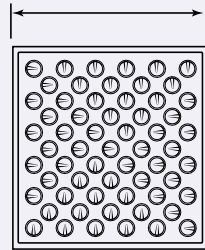

Diffuser with Side Entry Box

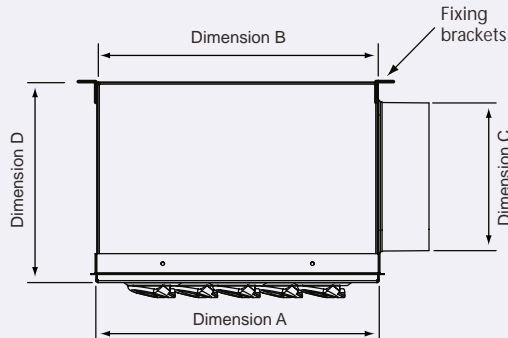

MND - SEB				
SIZE	DIM A	DIM B	DIM C	DIM D
300	474	472	200	300
	484	482		
	574	572		
	584	582		
400	474	472	250	350
	484	482		
	574	572		
	584	582		
500	474	472	315	415
	484	482		
	574	572		
	584	582		
600	574	572	350	450
	584	582		

Diffuser with Top Connection Box

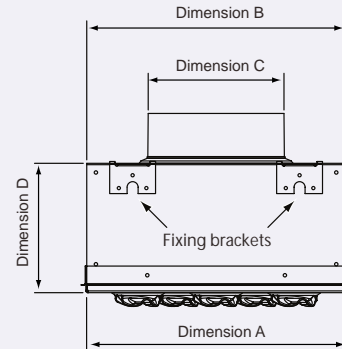

MND - TCB				
SIZE	DIM A	DIM B	DIM C	DIM D
300	474	472	200	150
	484	482		
	574	572		
	584	582		
400	474	472	250	200
	484	482		
	574	572		
	584	582		
500	474	472	315	250
	484	482		
	574	572		
	584	582		
600	574	572	350	300
	584	582		

Note: All diffusers should be independently supported. Standard fixing for all units is via drop rod (by others) to either elongated the slots in the plenum hanging brackets or the dedicated holes in the diffuser frame.



SERIES MN

Volume
Control

IRIS DAMPER

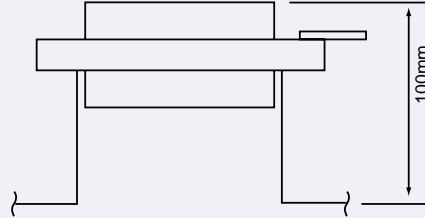

TYPE TCB & SEB: QUADRANT DAMPER

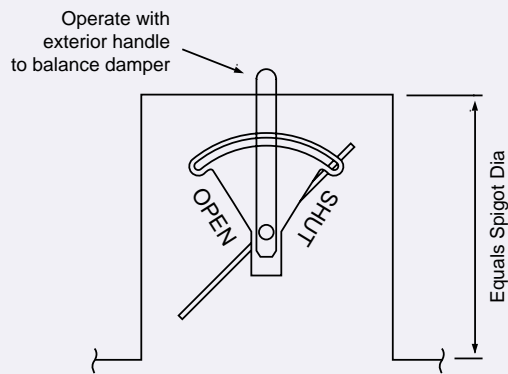

CORD OPERATED DAMPER

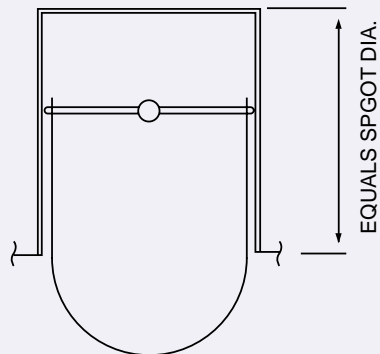

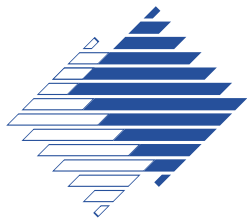

SERIES MN

Sizing Data

300 HORIZONTAL

Total Volume (l/s)	35	48	61	74	87	100
Noise Level (NC)	20	25	30	35	40	45
Static Press. (Pa)	7	14	22	35	43	60
Δt +10K	0.3/0.9	0.5/1.0	0.7/1.2	1.0/1.5	1.3/1.9	1.6/2.3
Δt +5K	0.3/0.9	0.5/1.0	0.7/1.2	1.0/1.4	1.2/1.8	1.5/2.0
Isothermal	0.3/0.7	0.5/0.9	0.7/1.1	0.9/1.3	1.1/1.6	1.4/1.8
Δt -5K	0.3/0.6	0.5/0.8	0.6/0.9	0.7/1.0	0.8/1.2	1.0/1.5
Δt -10K	0.3/0.5	0.5/0.6	0.5/0.8	0.6/1.0	0.7/1.1	0.9/1.4

300 VERTICAL

Total Volume (l/s)	35	48	61	74	87	100
Noise Level (NC)	20	25	30	35	40	45
Static Press. (Pa)	7	14	22	35	43	60
Δt +10K	0.3/0.5	0.4/0.7	0.5/1.0	0.6/1.2	0.7/1.4	0.8/1.6
Δt +5K	0.5/0.8	0.7/1.1	0.8/1.4	0.9/1.7	1.0/1.9	1.2/2.1
Isothermal	0.6/1.1	0.9/1.4	1.1/1.7	1.3/2.0	1.5/2.3	1.8/2.6
Δt -5K	0.8/1.5	1.2/2.0	1.6/2.5	1.7/2.8	1.8/3.1	2.0/3.5
Δt -10K	1.0/1.8	1.5/2.3	2.0/2.8	2.2/3.3	2.4/4.0	2.6/4.5

400 HORIZONTAL

Total Volume (l/s)	50	75	100	125	150	175
Noise Level (NC)	20	25	30	35	40	45
Static Press. (Pa)	6	13	22	35	50	68
Δt +10K	0.3/1.3	0.7/1.7	1.1/2.1	1.5/2.6	1.9/3.1	2.4/3.7
Δt +5K	0.3/1.2	0.5/1.4	0.9/1.7	1.3/2.1	1.7/2.5	2.1/3.1
Isothermal	0.3/0.8	0.3/1.1	0.7/1.4	1.1/1.8	1.5/2.1	1.9/2.5
Δt -5K	0.3/0.6	0.4/0.9	0.7/1.3	1.0/1.6	1.3/2.0	1.8/2.4
Δt -10K	0.3/0.5	0.5/0.8	0.6/1.2	0.8/1.5	1.1/1.9	1.6/2.3

400 VERTICAL

Total Volume (l/s)	50	75	100	125	150	175
Noise Level (NC)	20	25	30	35	40	45
Static Press. (Pa)	6	13	22	35	50	68
Δt +10K	0.8/1.2	1.0/1.4	1.2/1.7	1.4/1.9	1.6/2.2	1.8/2.5
Δt +5K	1.1/1.5	1.3/1.8	1.5/2.1	1.8/2.4	2.0/2.7	2.3/3.0
Isothermal	1.5/2.0	1.9/2.5	2.3/3.0	2.7/3.5	3.1/4.0	3.5/4.5
Δt -5K	2.3/3.0	3.0/4.1	4.0/4.8	5.0/6.0	--/--	--/--
Δt -10K	3.2/4.5	4.3/5.5	5.0/--	6.0/--	--/--	--/--

500 HORIZONTAL

Total Volume (l/s)	100	130	160	190	220	250
Noise Level (NC)	25	30	35	40	45	45
Static Press. (Pa)	10	17	26	37	49	63
Δt +10K	0.7/1.3	1.2/1.8	1.7/2.2	2.2/2.8	2.7/3.1	3.1/3.5
Δt +5K	0.5/1.2	0.9/1.6	1.4/2.0	1.8/2.5	2.2/2.8	2.9/3.2
Isothermal	0.4/1.1	0.7/1.5	1.1/1.8	1.4/2.2	1.8/2.5	2.3/2.9
Δt -5K	0.4/1.2	0.6/1.6	0.9/1.9	1.2/2.3	1.5/2.6	1.8/3.0
Δt -10K	0.4/1.3	0.5/1.7	0.7/2.0	1.0/2.4	1.2/2.8	1.4/3.2

500 VERTICAL

Total Volume (l/s)	100	130	160	190	220	250
Noise Level (NC)	25	30	35	40	45	45
Static Press. (Pa)	10	17	26	37	49	63
Δt +10K	0.4/0.8	0.6/1.1	0.9/1.5	1.2/1.8	1.5/2.1	2.0/2.5
Δt +5K	0.6/1.2	1.0/1.7	1.2/2.2	1.4/2.7	1.8/3.1	2.2/3.6
Isothermal	1.3/2.0	1.6/2.7	1.9/3.3	2.1/3.9	2.4/4.5	2.7/5.1
Δt -5K	2.0/2.5	2.4/3.3	3.0/3.8	3.5/4.5	4.0/5.0	4.4/5.7
Δt -10K	2.5/3.0	3.3/3.8	4.0/4.3	4.9/5.1	5.4/5.6	6.0/6.4

600 HORIZONTAL

Total Volume (l/s)	125	170	215	260	305	360
Noise Level (NC)	25	30	35	40	40	45
Static Press. (Pa)	7	13	22	31	47	60
Δt +10K	0.8/2.6	1.3/3.6	1.8/4.5	2.2/5.0	2.8/5.6	3.3/6.5
Δt +5K	0.6/2.0	1.1/2.8	1.4/3.5	1.8/4.0	2.2/4.5	2.8/4.8
Isothermal	0.5/1.5	0.8/2.0	1.1/2.5	1.5/2.8	2.3/3.2	2.4/3.5
Δt -5K	0.5/1.8	0.9/2.5	1.3/3.1	1.7/3.5	2.4/4.0	2.6/4.5
Δt -10K	0.6/2.2	1.1/3.0	1.5/3.8	2.0/4.2	2.5/5.1	3.0/5.8

600 VERTICAL

Total Volume (l/s)	125	170	215	260	305	360
Noise Level (NC)	25	30	35	40	40	45
Static Press. (Pa)	7	13	22	31	47	60
Δt +10K	0.6/0.8	0.9/1.1	1.1/1.5	1.5/1.8	1.8/2.0	2.0/2.3
Δt +5K	0.8/1.0	1.2/2.0	1.6/2.3	2.0/2.6	2.5/3.0	3.1/3.5
Isothermal	1.8/2.0	2.5/2.8	3.0/3.5	3.6/4.2	4.0/5.0	4.6/5.8
Δt -5K	1.9/2.2	2.6/3.2	3.5/4.0	3.9/5.0	4.5/--	5.0/--
Δt -10K	2.0/2.5	2.8/4.0	4.0/5.2	5.0/--	6.2/--	7.5/--

* Throw: The first figure corresponds to 0.5 m/s the second figure to 0.25 m/s

* N.C. Levels. No allowance has been made for room absorption.

* The above performance figures are for swirl set up.

* All data includes connection boxes.

* Throw Multiplication factors need to be applied for other distribution patterns as follows,

4 way: x 1.5

3 way: x 2

2 way: x 3

1 way: x 5



SERIES MN

Ordering Specification Diffuser

SERIES: MN-A, B, C OR D	MN-C	400	594	PIP 19	TD8	PPC RAL 9010 20% GLOSS (STANDARD FINISH)	15
LIST SIZE (Nom. Size) (300, 400, 500 Or 600)							
OVERALL SIZE (mm)							
PIP HEIGHT (mm) (Applies to MN-B only)PIP + HEIGHT							
REGULAR DROP DEPTH mm (MN-D Only)							
FINISH (Please Specify)							
NUMBER REQUIRED							

Swirl Distribution

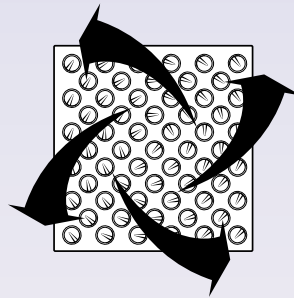

4 Way

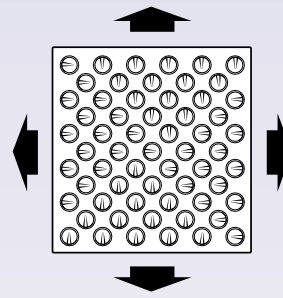

3 Way

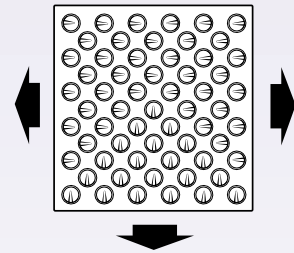

2 Way

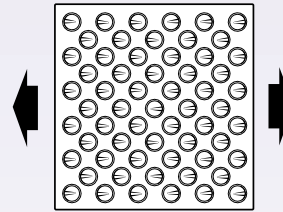

1 Way

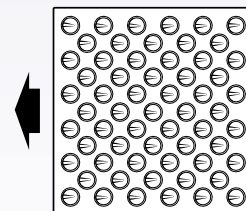

Vertical Distribution

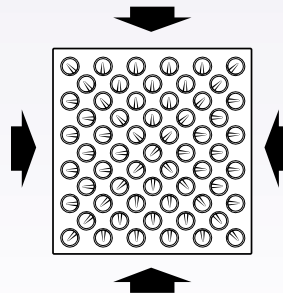



SERIES MN

Ordering Specification Plenum

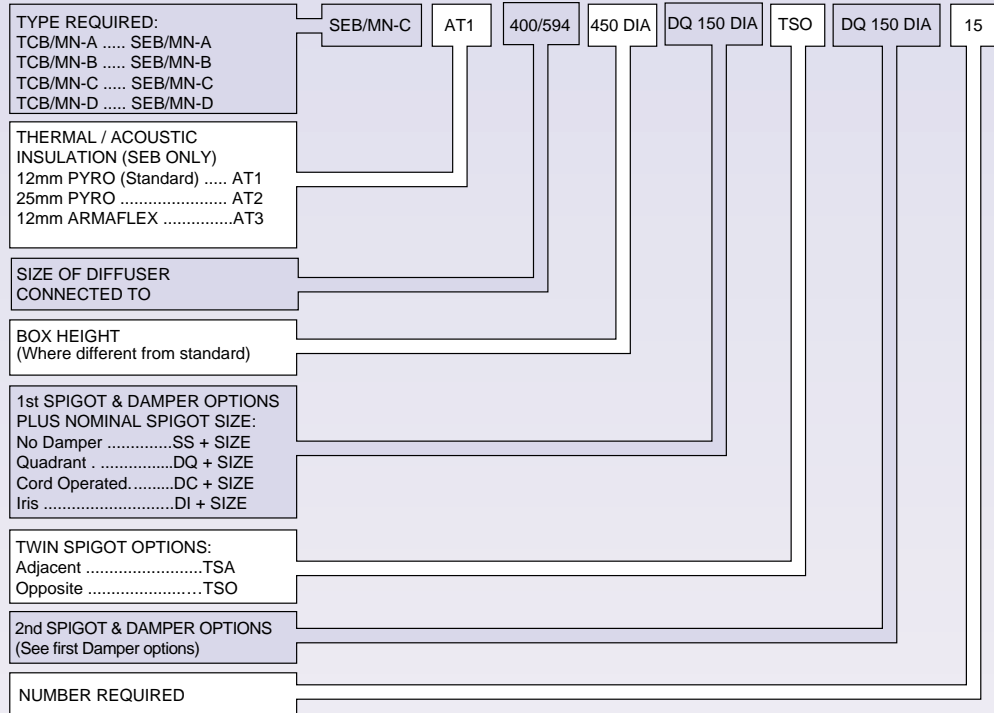

SIZE RANGE

Available list sizes are 300, 400, 500 and 600mm square. Different overall sizes are available for each list size to suit specific ceiling details.

AIR PATTERNS

Units are supplied with distribution factory set in the swirl air pattern. Units can easily be reset on site if required. Please refer to the air pattern settings on page 11.

PLENUM SPECIFICATION

0.7mm Galvanised or Zintec coated mild steel plenum. Spigot Construction: Standard size spigots use plastic clip-in spigots. Non standard a sealed screw in spigot.

FIXING

All diffusers should be independantly supported. Standard fixing for all units is via drop rod (by others) to either the elongated slots in the plenum hanging brackets or the dedicated holes in the diffuser frame.

FINISH

Standard finish is Polyester powder White RAL 9010 20% Gloss for the fascia with the nozzles formed in matching colour. Other RAL colours are available dependant on economic quantity. Please contact our Sales Office.

Contact

GILBERTS

Head Office and Works
GILBERTS (BLACKPOOL) LTD
Gilair Works, Clifton Road,
Blackpool.
Lancashire FY4 4QT.
Telephone: (01253) 766911
Fax: (01253) 767941
e-mail: sales@gilbertsblackpool.com
Web: www.gilbertsblackpool.com

