

# SERIES PGL

## Laminar Flow Panels

PUBLICATION

DIFFUSERS 5

MARCH 2009

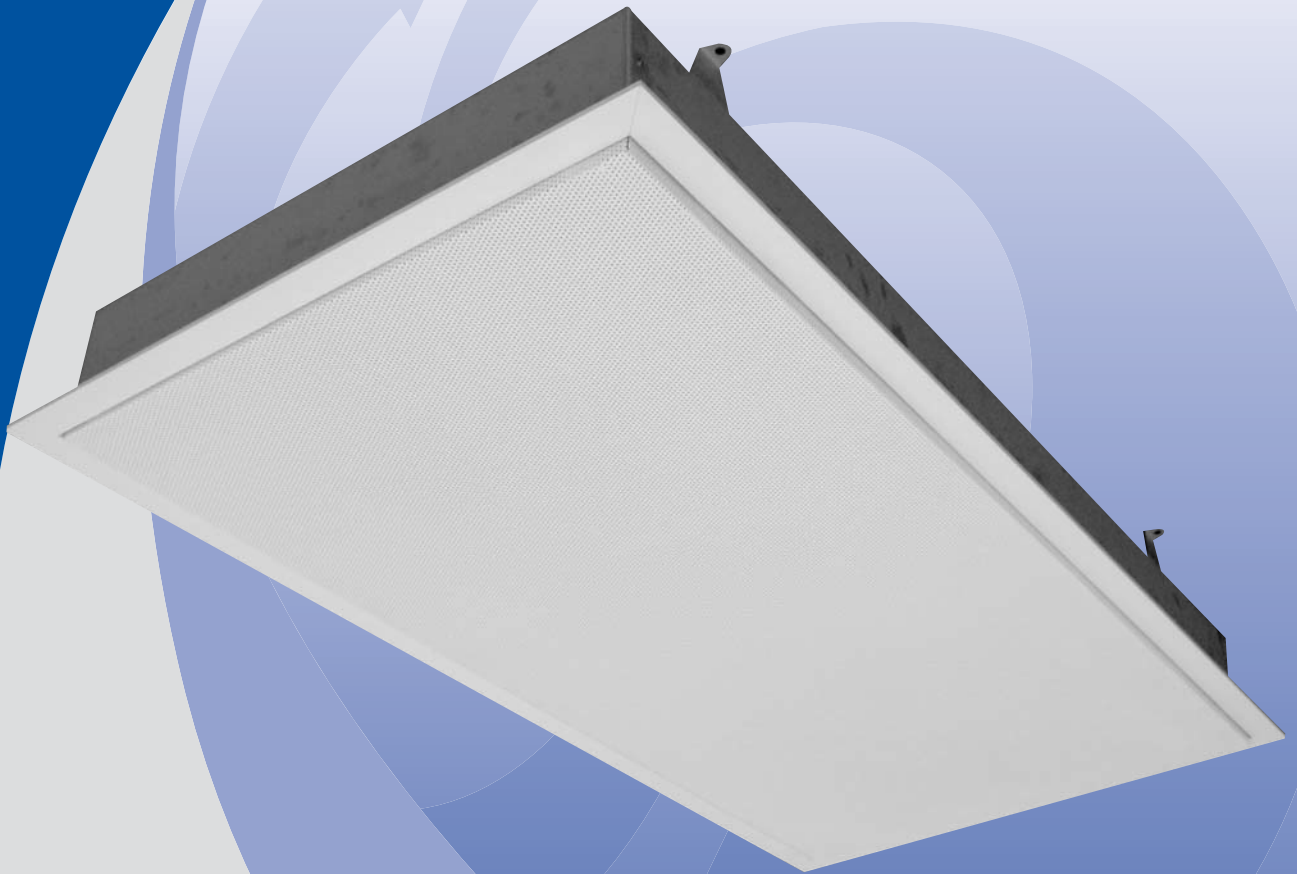

### Features

- High Capacity
- Single or Multiple Panel Assemblies
- Circular Inlets with top entry
- Rotary Blade Damper Control on PGL1 and PGL2
- Extruded Aluminium frame with Mild Steel Fascia
- Hinged opening fascia for access and cleaning



# GILBERTS



# SERIES PGL

## Introduction

Gilberts Series PGL provides a range of Laminar Flow Panels are suitable for use in operating theatres, laboratories, clean rooms and other similar applications. Unlike a conventional ceiling diffuser the Laminar Flow Panel provides an equalised turbulence free input of air into the treated zone creating a vertical air projection with little in the way of back drafts or inter-mixing. In this way a clean uncontaminated air zone can be supplied to surround critical areas ie: operating tables and work tops. These units are mainly used for cooling or isothermal conditioning because of the buoyancy effect of the supply air and, unless low level extract is provided, under heating conditions large

temperature differentials will occur between the floor and ceiling levels.

Laminar Flow Panels are available either in multiple format PGL1 for coverage of large zonal areas or as individual units PGL2 for discreet supplies throughout the space. The PGL2 units are also offered with three different types of border to suit current popular ceiling designs.

**TYPE PGL 1** - Laminar Flow diffuser designed to form multiple panel assembly.

**TYPE PGL 2** - Single unit Laminar Flow diffuser with 32mm flange border frame.

**TYPE PGL 2/T** - Single unit Laminar Flow diffuser with tegular border frame.

**TYPE PGL 2/B** - Single unit Laminar Flow diffuser with clip in border frame.

The perforated diffuser face has a low free area, approximately 15%, with standard unit sizes being 600 x 600, 900 x 600 and 1200 x 600 with models to fit in both plasterboard ceilings and modern ceiling grids. The units are manufactured from an extruded aluminium frame and mild steel perforated face with the Plenum chambers in steel zintec. The diffuser is finished as standard in a white polyester powder coating. In PGL1 format the unit can, in fact, be built up to form a complete Laminar Flow ceiling with

appropriate location points for light fittings and other services. Volume control can be achieved on both PGL1 and PGL 2 by fitting a rotary damper to the plenum inlet spigot of each panel with access for adjustment by removal of the face plate.

Duct mounted volume control dampers for balancing can also be supplied in quadrant or iris designs, with circular connections standard on all types.

## Features

- High capacity
- Single or Multiple panel assemblies
- Circular inlets with top entry
- Rotary Blade damper control on PGL1 and PGL2 units
- Extruded aluminium frame and mild steel fascia
- Hinged opening fascia for access and cleaning

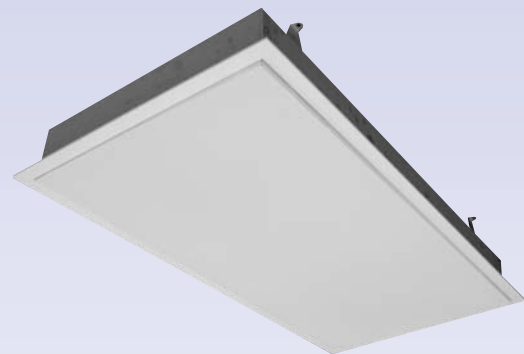

## Selection Procedure

Firstly the following parameters must be established:

- A** Total air volume for space to be conditioned.
- B** Ceiling Height
- C** Maximum temperature differential (generally on cooling). Please note that very little throw is achieved using these units for heating only in the higher volume ranges.
- D** Throws required vertically, generally to the occupied zone. This must correspond to the required terminal velocities.
- E** Maximum noise levels. Please note that data is only available down to NC20.

Having established the above parameters, select a unit from the performance data to correspond with the noise level and throw requirements. From this selection note the air volume per unit. Divide this air volume into the total air volume for the space and thus arrive at a total number of supply units.

## EXAMPLE:

- A** Total volume for space 2 m<sup>3</sup>/s
- B** 3m ceiling height
- C** 5°C cooling maximum
- D** Throws required are 2.5m to 0.25m/s and 1.5m to 0.5m/s
- E** Maximum noise level NC 30

From 5°C cooling section on chart, select unit with a total volume of 0.15m<sup>3</sup>/s. Check other parameters ie: static pressure 4 Pa, NC 20, throws 1.5 to 2.5. Now divide 2m<sup>3</sup>/s by 0.15m<sup>3</sup>/s. Which equals 13.33 units rounded up to 14. these units must now be distributed evenly across the ceiling area to give the best possible coverage over the entire space.



# SERIES PGL

## Series PGL 1 Assembly Type 1

Assembly Type 1  
3m x 3m design

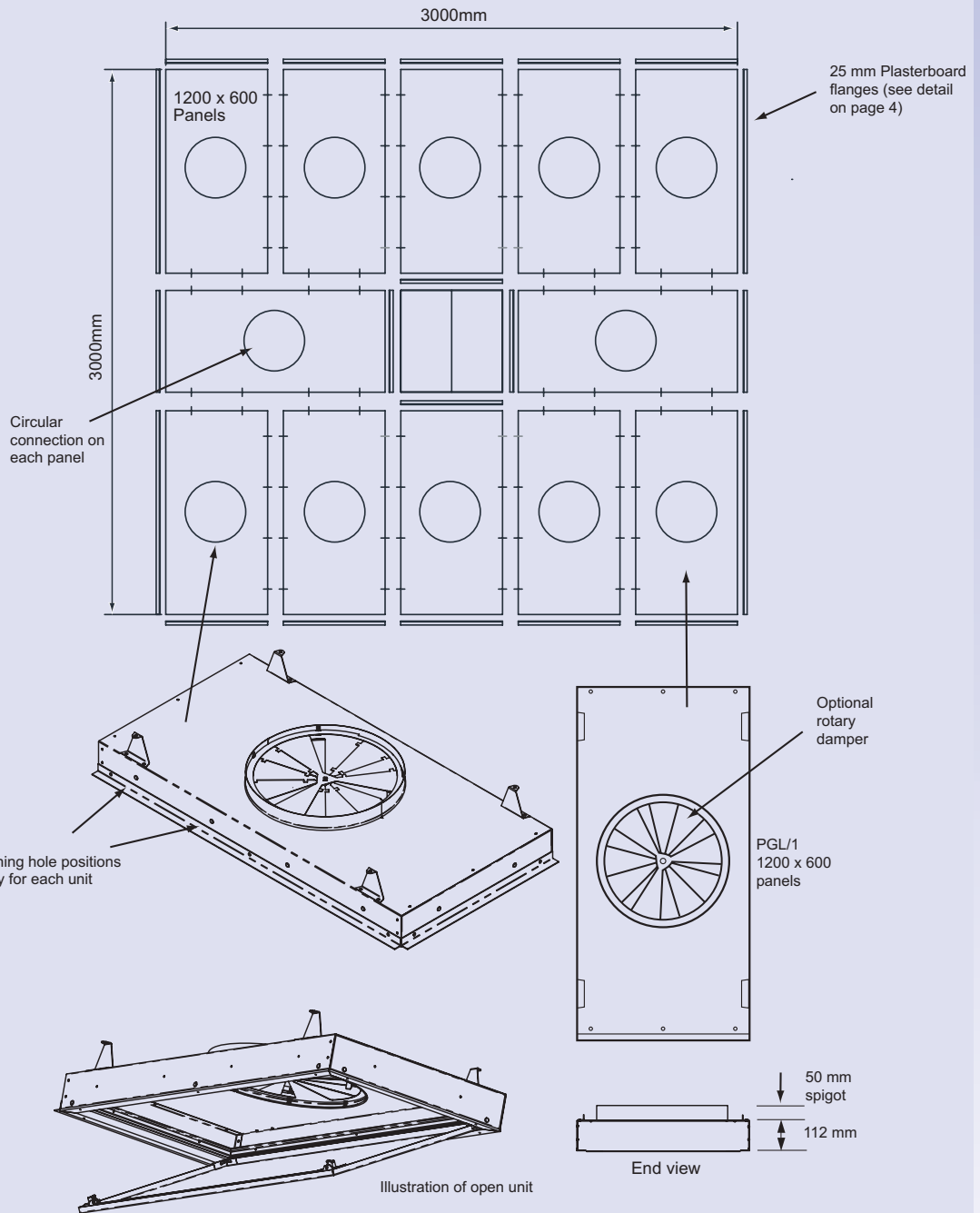



# SERIES PGL

## Series PGL 1 Assembly Type 2

Assembly Type 2  
3m x 2.4m design

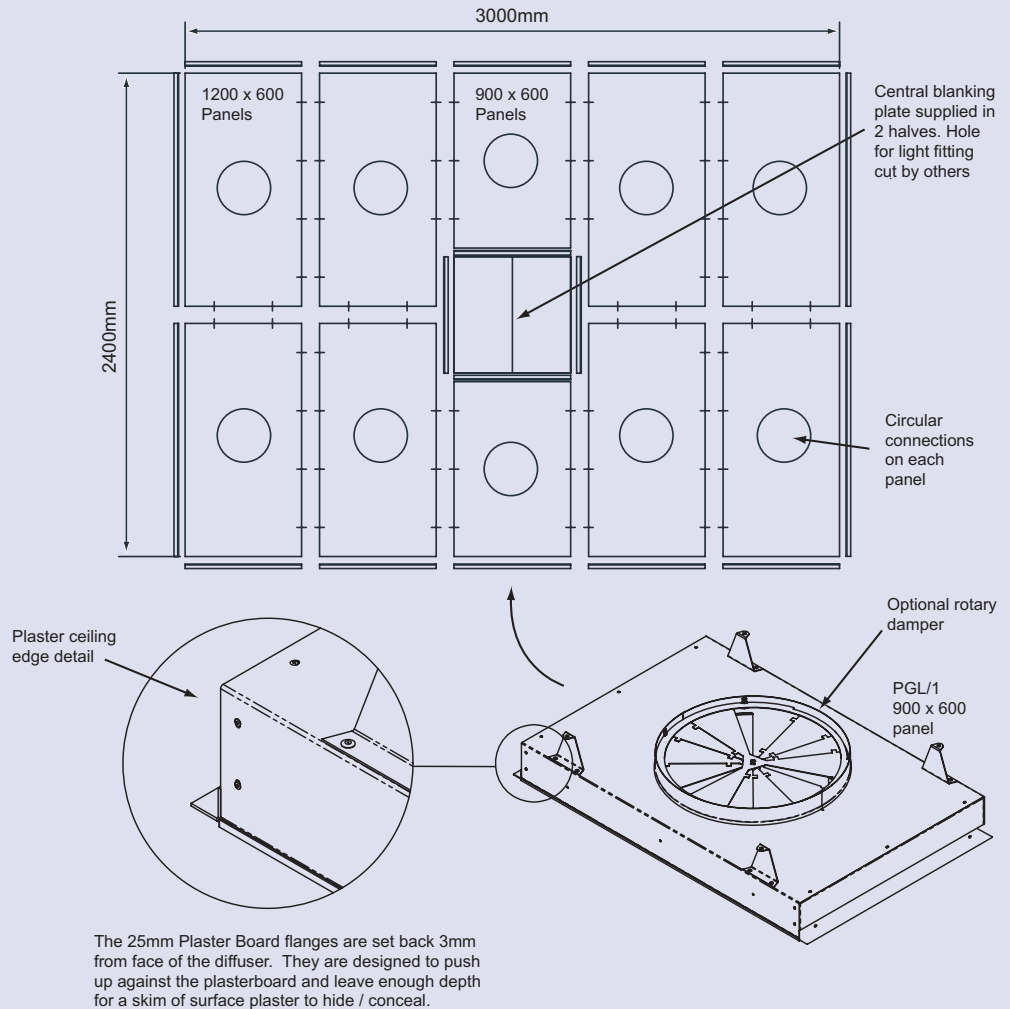

## Series PGL 1 Assembly Type 3

Assembly Type 3  
1.8m x 1.2m design

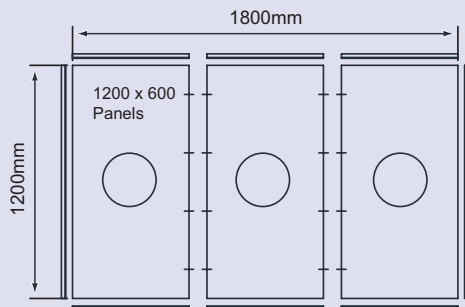

## Series PGL 1 Assembly Type 4

Assembly Type 4  
3.6m x 0.6m design

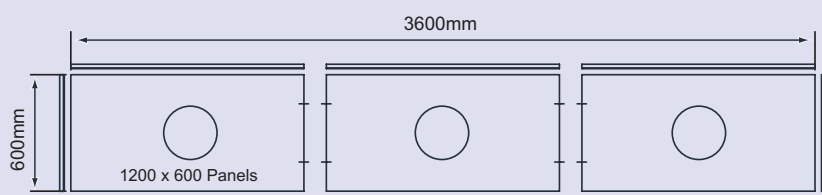



# SERIES PGL

## Series PGL2

Single Unit  
Assemblies

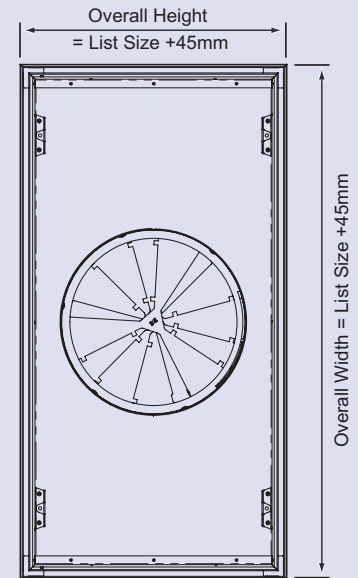
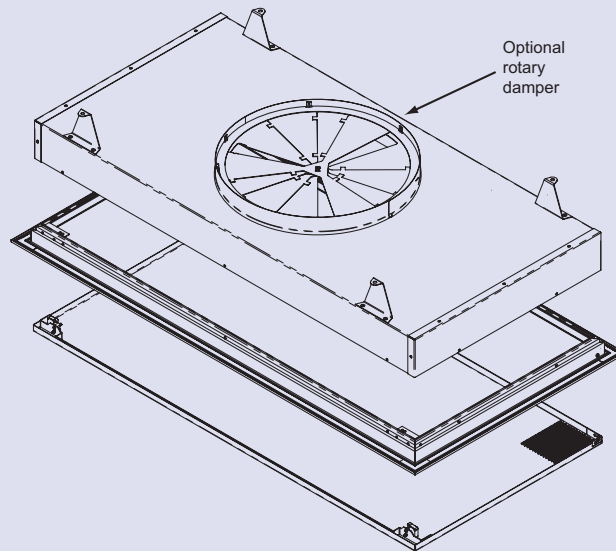

We offer two size options for the PGL2 with a larger unit to suit plaster ceilings and slightly smaller unit to provide an overall size designed to fit regular T bar type ceiling grids.

For Tegular or Clip in ceiling grids please see details for types PGL2/B and PGL2/T on page 6.

### List Sizes W x H

#### Plaster Ceiling

1200 x 600mm  
900 x 600mm  
600 x 600mm

#### T Bar Ceiling Grid

1150 x 550mm  
850 x 550mm  
550 x 550mm

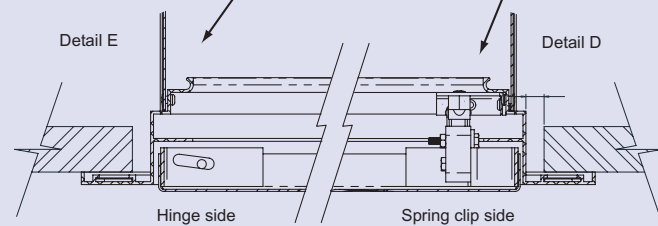
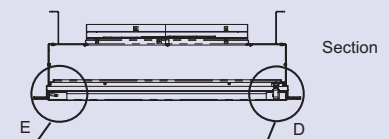
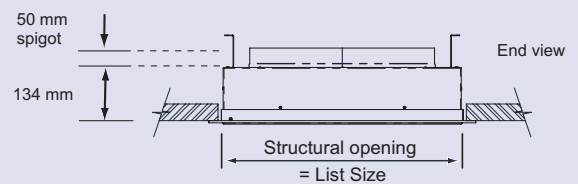



# SERIES PGL

## Series PGL/2/T Tegular Ceiling

The PGL/2/T option for the laminar flow diffuser features a border frame specially designed to suit modern 'tegular' type ceiling grids. This border, available on PGL/2/T units features a factory adjusted edge detail to suit drops of between 7 - 19mm allowing it to match with most popular ceiling types (please provide full ceiling details).

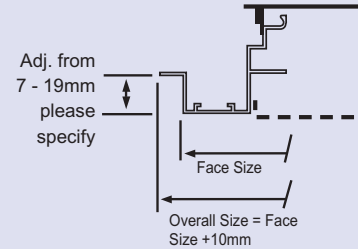

## Series PGL/2/B Clip-in Ceiling

The PGL/2/B option for the laminar flow diffuser features a border frame specially designed to suit popular clip-in type ceiling grids. Simply specify the ceiling pip height (normally 19 or 25mm) or provide full details of ceiling and we will include appropriate location/alignment clips to suit.

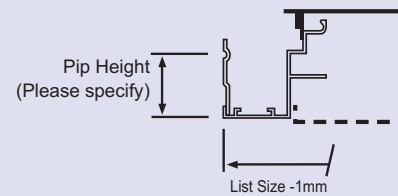

Type PGL2/T Tegular Ceiling

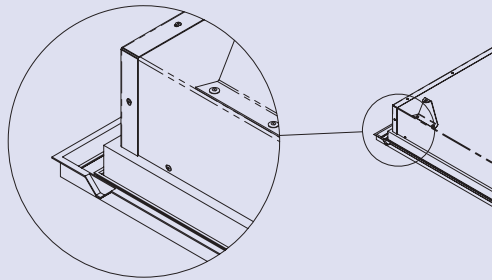

Type PGL2/B Clip in Ceiling

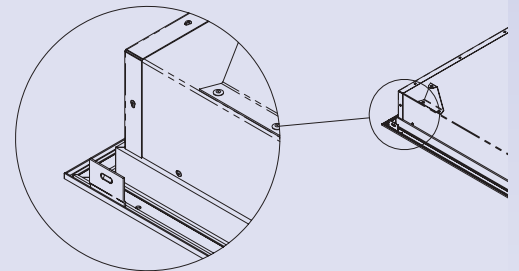

### Tegular Unit Sizes (W x H)

List Size 1200 x 600	Face Size 1184 x 584 or Face Size 1174 x 574
List Size 900 x 600	Face Size 984 x 584 or Face Size 974 x 574
List Size 600 x 600	Face Size 584 x 584 or Face Size 574 x 574

Face size to be specified to suit ceiling  
Overall size = Face size + 10mm

### Clip-In Unit Sizes (W x H)

1200 x 600 mm
900 x 600 mm
600 x 600 mm

## Rotary Dampers

The Rotary damper is a new alternative to fitting a quadrant damper on the plenum inlet allowing damper adjustment from the diffuser face. The damper can simply be manually adjusted/rotated to the required position using the tabs on the damper face. For access to the damper the hinged diffuser face must first be opened.

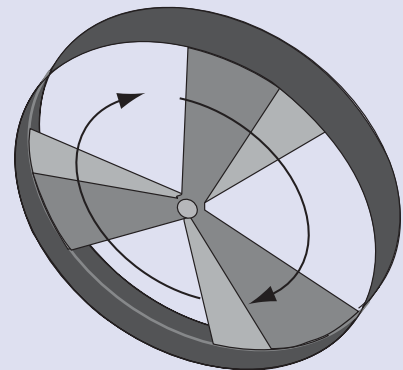



# SERIES PGL

## Sizing and Performance Data

ISOTHERMAL CONDITIONS								
Volume m <sup>3</sup> /s	0.05	0.10	0.15	0.2	0.25	0.3	0.35	Angle of discharge 12° from vertical
NC Level		20	20	25	30	35	40	
Static Pressure Pa	1	2	4	7	14	18	23	
Throw m	0.5-1.0	0.8-1.3	0.8-1.5	0.9-1.8	1.5-2.0	1.8-2.2	2.0-2.3	
5°C COOLING								
Volume m <sup>3</sup> /s	0.05	0.10	0.15	0.2	0.25	0.3	0.35	Vertical discharge
NC Level		20	20	25	30	35	40	
Static Pressure Pa	1	2	4	8	14	18	23	
Throw m	1.0-2.0	1.3-2.3	1.5-2.5	1.6-2.5	1.8-2.8	2.0-3.0	2.2-3.5	
10°C COOLING								
Volume m <sup>3</sup> /s	0.05	0.10	0.15	0.2	0.25	0.3	0.35	Vertical discharge
NC Level		20	20	25	30	35	40	
Static Pressure Pa	1	2	4	6	14	18	23	
Throw m	1.2-2.2	2.0-2.5	2.2-2.8	2.3-3.0	2.5-3.2	2.8-3.5	3.0-4.0	
5°C HEATING								
Volume m <sup>3</sup> /s	0.05	0.10	0.15	0.2	0.25	0.3	0.35	Angle of discharge 12° from vertical
NC Level		20	20	25	30	35	40	
Static Pressure Pa				7	14	18	23	
Throw m				0.5-0.8	0.5-1.0	1.3-1.6	1.4-1.8	
10°C HEATING								
Volume m <sup>3</sup> /s	0.05	0.10	0.15	0.2	0.25	0.3	0.35	Angle of discharge 12° from vertical
NC Level		20	20	25	30	35	40	
Static Pressure Pa				7	14	18	23	
Throw m				0.5-0.8	0.5-1.0	0.8-1.2	1.2-1.5	

**THROW:** First figure corresponds to 0.5m/s, second Figure to 0.25m/s (max figures)

**NC LEVELS:** No room correction figures have been deducted

**SIZE:** Tables based on 1200 x 600 panel

**Note:**

- For 600 x 600 Units:-
- 1 Double the volume per panel and use figures above.
  - 2 Reduce throw by 1/3rd
  - 3 NC Levels take as above but for double the volume
  - 4 Circular connection (200 diameter)

- For 900 x 600 Units:-
- 1 Increase the volume per panel by 1/3rd and use figures above.
  - 2 Reduce throw by 1/6th
  - 3 NC Levels take as above with volume per panel increased by 1/3rd
  - 4 Circular connection (250 diameter)

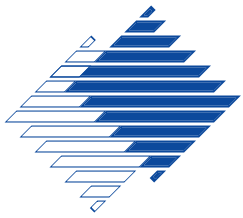

# SERIES PGL

## Ordering Specification

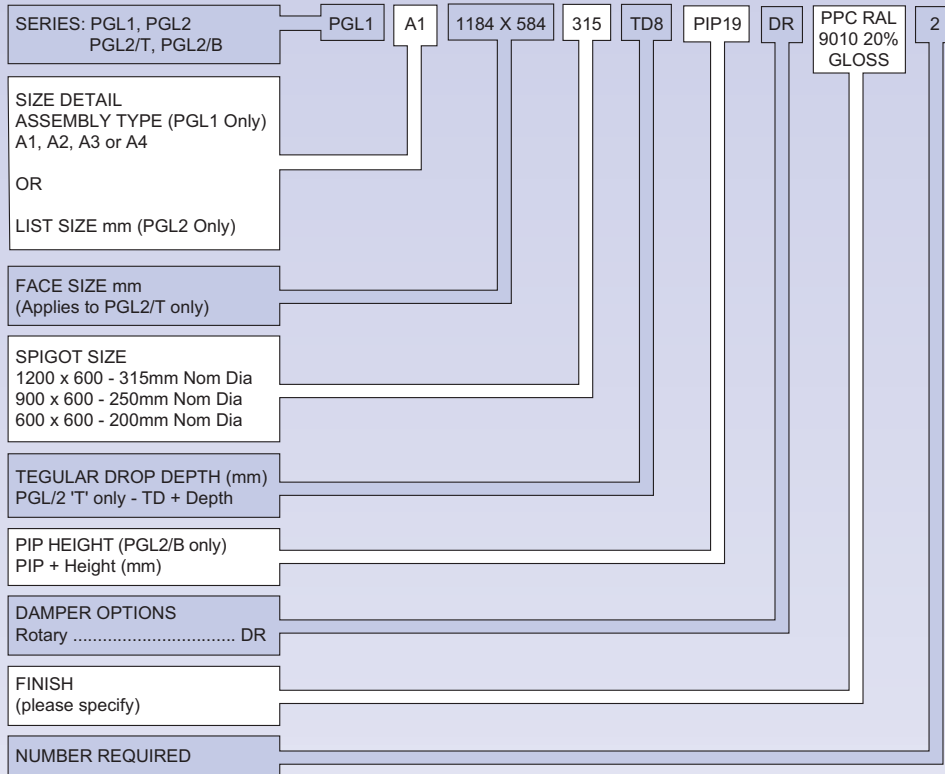

**Note** - All units are supplied with circular top inlet connection as standard.

1200 x 600 - 315 Dia inlet  
900 x 600 - 250 Dia inlet  
600 x 600 - 200 Dia inlet

Where assembly type 1 to 4 is ordered please detail spigot sizes where different from standard for each unit / module.

### FINISH

**STANDARD FINISH:**  
Polyester Powder White RAL 9010  
20% gloss. NB. Plenum Box supplied -  
natural zintec finish.

**SPECIAL FINISHES:**  
Polyester Powder Finish to stock BS/RAL  
colour.

### FIXING

Standard fixing for all units is via drop  
rods (by others) to 8mm diameter  
holes in the angle cleats  
at the rear.

## Contact

### GILBERTS

Head Office and Works  
**GILBERTS (BLACKPOOL) LTD**  
Gilair Works, Clifton Road,  
Blackpool.  
Lancashire FY4 4QT.  
Telephone: (01253) 766911  
Fax: (01253) 767941  
e-mail: sales@gilbertsblackpool.com  
Web: www.gilbertsblackpool.com

