

SERIES GSL

Linear
Slot
Diffuser

PUBLICATION

DIFFUSERS 6

OCTOBER 2008



Curved Linear
Slot Diffuser



Features

- One to Eight Slot Widths.
- Adjustable for Horizontal & Vertical Distribution.
- Unique Multi Purpose Removable Air Deflection Vane.
- Comprehensive Series of Matching Plenums.
- Alternative Border Options to Suit Popular Ceiling Designs.
- Curved Patterns Available.
- Extruded Aluminium Construction.



GILBERTS

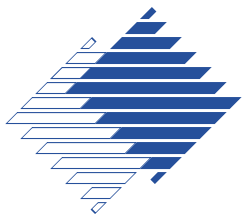

SERIES GSL

Introduction

Gilberts GSL Series of Linear Slot Diffuser has been designed to meet the exacting performance requirements and standards of modern slot diffuser applications. Combining up to date styling and design technology to blend with modern architecture the GSL maintains excellent air distribution characteristics providing smooth, accurate and flexible airflow control making the unit suitable for both fan coil, VAV and conventional Linear Slot applications.

Available in standard one to eight slot widths the unit is suitable for sidewall or ceiling mounting applications and is manufactured from extruded aluminium with a plastic air deflection blade. Single units can be supplied up to 2.0m in length with longer runs supplied in sections and joined,

almost invisibly, by a simple, accurate and effective alignment feature.

The diffuser incorporates a discreet directional control vane in each slot to direct the airflow across the ceiling, left or right, or discharge vertically downwards. Arranged in standard 2000mm lengths, the blade offers a clean unbroken appearance and is easily clipped and unclipped from the diffuser to allow for fixing.

Alternatively the control vane can be supplied in small 100mm adjustable sections (Type GSLM). This allows for further close control of the supply air jets to provide a multi directional array as shown on page 3.

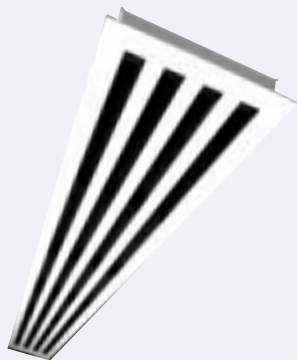

Features

- One To Eight Slot Widths.
- Adjustable For Horizontal And Vertical Distribution.
- Unique Multi Purpose Removable Air Deflection Vane.
- Comprehensive Series Of Matching Plenums.
- Alternative Border Options To Suit Popular Ceiling Designs.
- Curved Patterns Available.
- Extruded Aluminium Construction.

The standard border detail comprises a 27mm flange border with end flanges or end caps optionally available. In keeping with contemporary ceiling design, however, the GSL series is also available with alternative border styles to match different popular ceiling types and mitred corners can also be included.

In addition, the GSL is complemented by a comprehensive range of purpose built Plenum boxes. Manufactured from Galvanised or Zintec coated Mild Steel the boxes can be supplied to suit all diffusers in sectional box lengths up to 2000mm. Connection between the boxes and the diffusers can be accomplished either by drill and rivet through the diffuser neck or where access is limited, via concealed

HORIZONTAL DISTRIBUTION - 1 way
Airflow

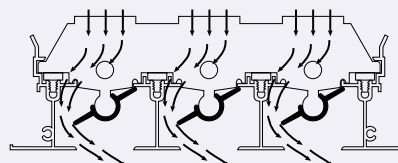

HORIZONTAL DISTRIBUTION - 2 way
Airflow

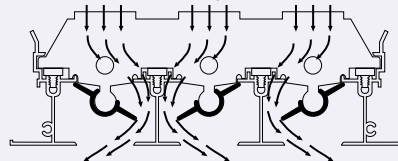

VERTICAL DISTRIBUTION

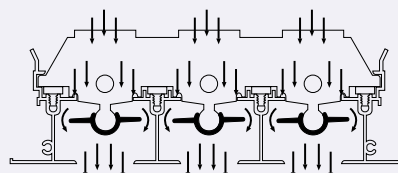

bracket fixings accessible through the diffuser face (standard fixing is concealed bracket). For even faster installation a toggle latch fixing is optional and, for installations without Plenums. The diffuser includes fixing holes for drop rod support as standard.

For volume control the standard Plenum inlet can be fitted with Quadrant or Iris type dampers and where adjustment via the slot face is preferred, both cord and teleflex operated spigot dampers can be installed.

Standard finish on all GSL Slot Diffuser is a White polyester powder coated face with all control vanes matt black. Other colours and finishes are available on request.

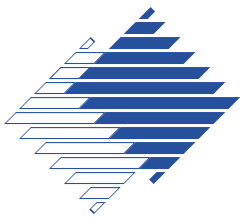

SERIES GSL

ALIGNMENT FEATURE

For long diffuser runs a concealed alignment feature is provided for positive and accurate joining of diffuser lengths whilst maintaining a clean unbroken appearance. Simply

align the units on site using the dowels and then push the 'fir tree' studs through the adjoining backstraps. A simple, straightforward and fast procedure.

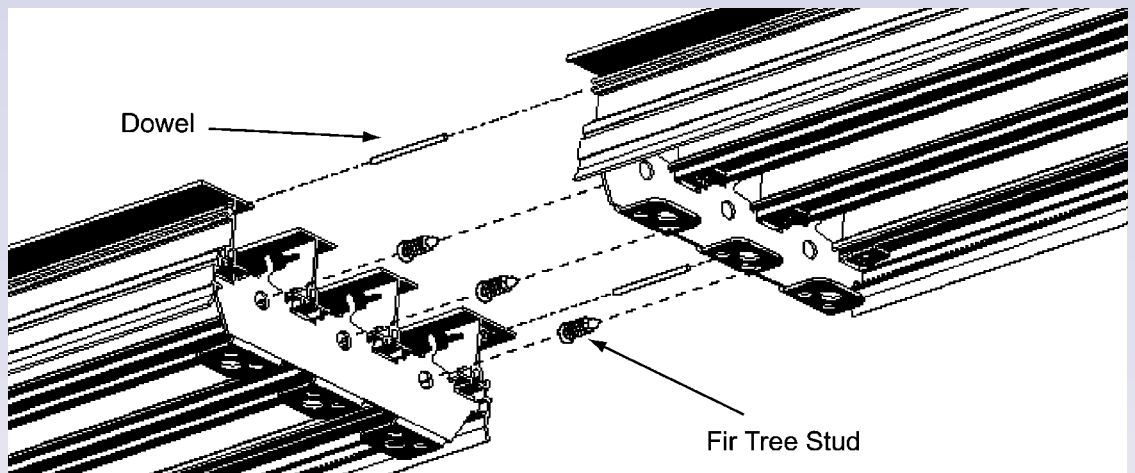

DIRECTIONAL CONTROL

Directional Control is achieved by adjustment of the control vane housed in each slot, moved left or right for opposite horizontal distribution and horizontal for vertical distribution. As standard airflow direction can be altered every 2000mm although smaller intervals can be easily achieved on site by

simply cutting the blade and inserting spacer brackets (see installation leaflet for details). Alternatively the diffuser can also be specified in multi-directional format (Type GSLM). On this model the blades are split every 100mm and can be set in alternating positions to give a multi directional discharge (see below).

DIRECTIONAL CONTROL

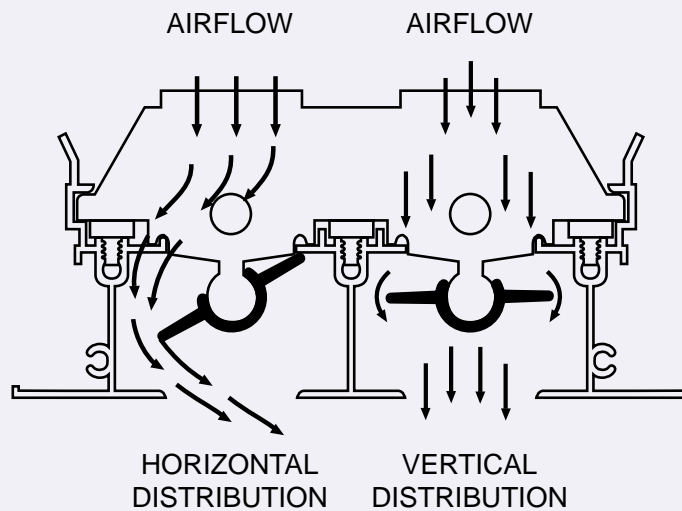

MULTI-DIRECTIONAL (TYPE GSLM)

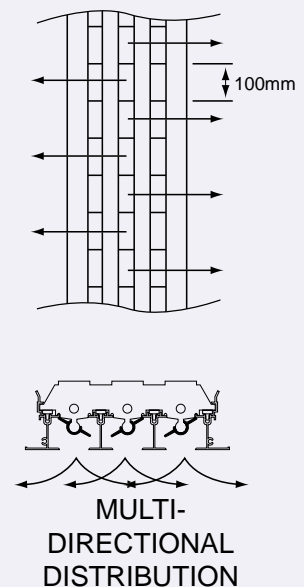

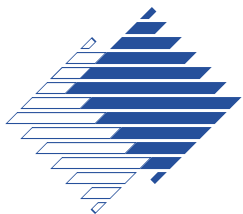

SERIES GSL

Selection Procedure

- 1 Establish a position within the conditioned space to achieve the best air distribution.
- 2 Knowing the type of space, refer to (table 1) and establish the recommended maximum noise level for that type of area.
- 3 Divide the total air volume (m^3/s) by the effective active length of diffuser and establish a volume per metre run.
- 4 Establish the throw based on notes in the performance specification.
- 5 Refer to selection NOMOGRAM and establish the number of slots required to meet your requirements

EXAMPLE

A 4 metre long diffuser is to be installed within an office area and is required to handle $0.2m^3/s$ Total. The throw is approximately 7 metres (to $0.25m/s$).

From (table 1) the maximum recommended NC level for this type of area is 30 -40.

Volume per metre run = $\frac{0.2}{4} = 0.05m^3/s/m$.

Now referring to selection NOMOGRAM it can be seen that a 2 slot diffuser will handle the required volume with an 5 metre horizontal throw . Since the unit selected is 4mm long this figure must then be multiplied by a correction of 1.4, thus giving a final throw of 7 metres. From the NOMOGRAM, noise level is approximately 20 and with the addition of the correction factor of 4 this gives a total noise level of < 25 NC. With a 15 Pa pressure drop the diffuser selected is suitable for this area.

Table 1

| Area to be served | Recommended Maximum NC Levels |
|--|-------------------------------|
| Sound Broadcasting, Recording Studios, TV (Audience Studios) | 15 - 20 20 - 25 |
| Lecture Theatres, Cinemas, Concert Halls, Boardroom/Ex Offices Lounge, Conference Room, Court Room, Churches, Private Bedrooms | 25 - 30 |
| Operating Theatres, Hospital Wards, Staff Room, Class Rooms, Ballroom, Banquet Room, Library, Bank, Museum, Offices | 30 - 40 |
| Restaurants, Department Stores, Computer Suite, Washroom Toilet | 35 - 40 |
| Laundries, Kitchens, Swimming Pools, Sports Arena | 40 - 45 |
| Garage, Light Engineering Workshop | 45 - 50 |
| Heavy Engineering Workshop | 50 - 65 |

PLENUM BOXES

Standard Plenum box details are shown in the Plenum Box section with inlet sizing data. This provides the recommended minimum to obtain even distribution along the diffuser using a centre fed constant cross section Plenum Box.

If side entry cannot be accommodated and only top entry is possible then all boxes should be complete with a perforated baffle section. Plenum Boxes are lengths up to 1800mm and are suitable for direct fixing through the neck of the diffuser, concealed bracket fixing or, where specified, toggle latch fixing. The Plenum to diffuser connection offers tight and secure fitting and provides an adequate air seal. However additional sealing may be applied on site at discretion. For low leakage ductwork applications in particular, secondary sealing is recommended.

VERTICAL PROJECTION

If the diffuser is next to a smooth vertical surface the throws given should be multiplied by a factor of 1.5. Also if a $10^{\circ}C \Delta t$ for heating or cooling applies the throws given should be multiplied by 0.75 or 1.3 respectively.

HORIZONTAL DIFFUSION

If the diffuser is mounted on exposed ductwork the throws given will be reduced by approximately 40%.

Performance Data

The performance data tables are information for cooling, ventilation and heating applications. The selection NOMOGRAM is based on a 1m length of diffuser complete with a standard Plenum box, and mounted flush with a ceiling. Isothermal conditions also apply, and correction notes following and factor tables opposite should be used for other sizes and applications.

- PRESSURE: All pressures are in Pa (N/m^2)
- THROWS: All horizontal and vertical throws are for a distance measured in metres, and correspond to a terminal velocity of 0.25 m/s and 0.75 m/s.
- SOUND: The NC values are based on a room absorption of 8 db re 10^{-12} watts, and for a 1m length of diffuser with damper fully open.

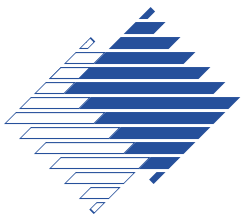

SERIES GSL

Slot Diffuser
Standard
Border A

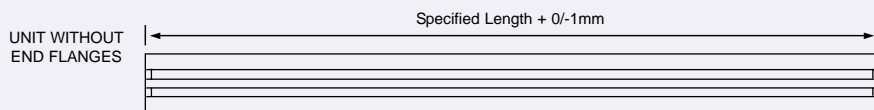
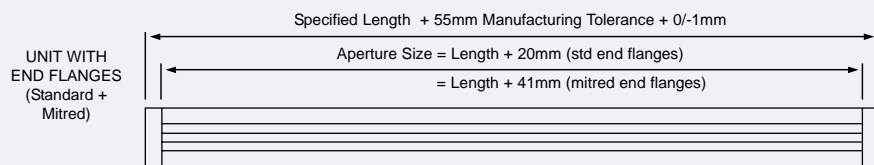
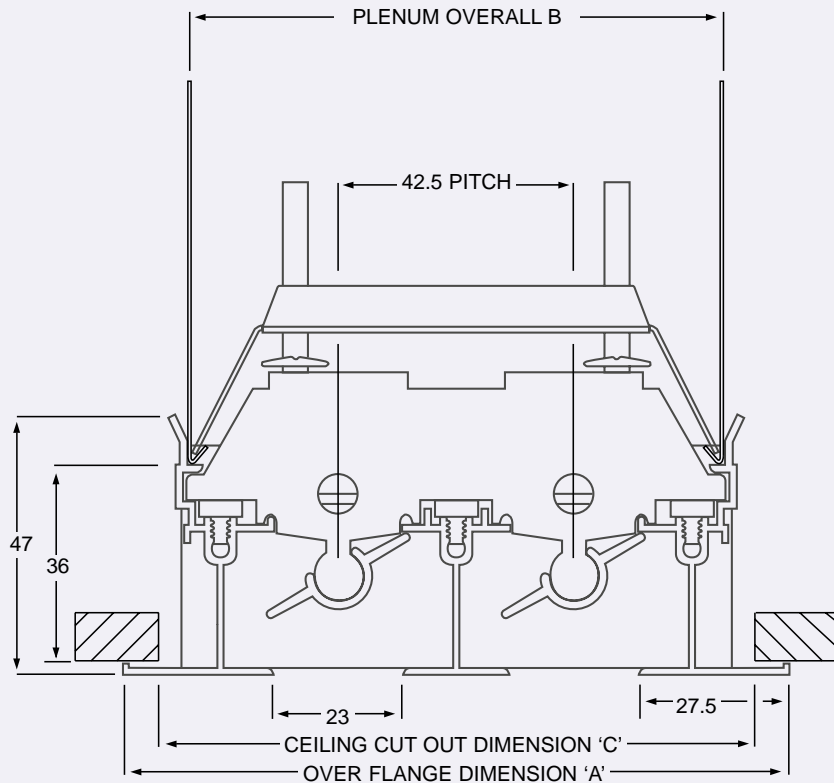

Mitred Corners

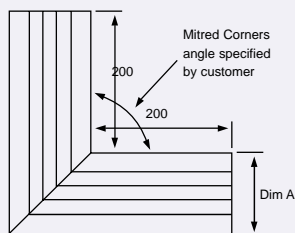

| Series | No of Slots | Dim A | Dim B | Dim C |
|--------|-------------|-------|-------|-------|
| GSL | 1 | 78 | 53.5 | 64 |
| GSL | 2 | 120.5 | 96 | 106.5 |
| GSL | 3 | 163 | 138.5 | 149 |
| GSL | 4 | 205.5 | 181 | 191.5 |
| GSL | 5 | 248 | 223.5 | 234 |
| GSL | 6 | 290.5 | 266 | 276.5 |
| GSL | 7 | 333 | 308.5 | 319 |
| GSL | 8 | 375.5 | 351 | 361.5 |

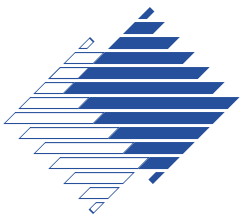

SERIES GSL

Special Border Option B (Plank Ceiling)

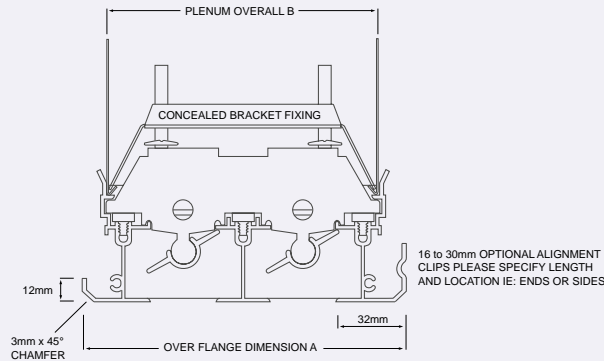

| No of Slots | A | B |
|-------------|-------|-------|
| 1 | 86.5 | 53.5 |
| 2 | 129 | 96 |
| 3 | 171.5 | 138.5 |
| 4 | 214 | 181 |
| 5 | 256.5 | 223.5 |
| 6 | 299 | 266 |
| 7 | 341.5 | 308.5 |
| 8 | 384 | 351 |

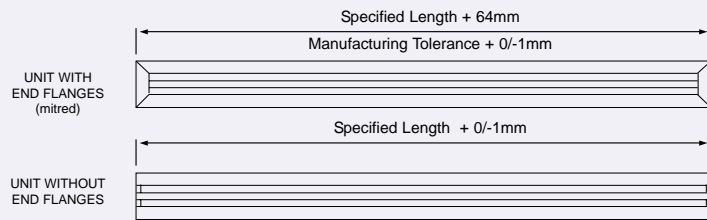

Plaster Ceiling (Border Option A Illustrated)

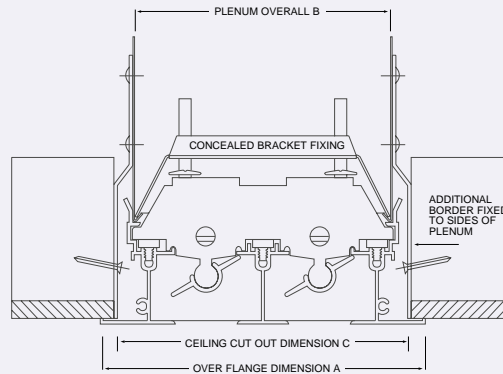

| No of Slots | Dim A | Dim B | Dim C |
|-------------|-------|-------|-------|
| 1 | 78 | 53.5 | 67.5 |
| 2 | 120.5 | 96 | 110 |
| 3 | 163 | 138.5 | 152.5 |
| 4 | 205.5 | 181 | 195 |
| 5 | 248 | 223.5 | 237.5 |
| 6 | 290.5 | 266 | 280 |
| 7 | 333 | 308.5 | 322.5 |
| 8 | 375.5 | 351 | 365 |

Note: Plaster ceiling Plenum arrangement and concealed bracket fixing compulsory

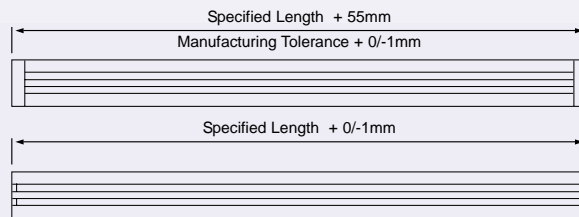

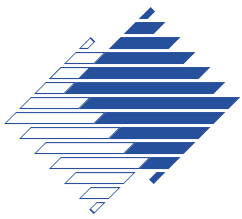

SERIES GSL

Curved Slot Diffuser

(TYPE GLSC)

The unique design of the GSL frame and directional control blade allows for shaping of the diffuser into a variety of curved patterns whether for architectural or aesthetic reasons. Importantly instead of being blanked or having dummy sections however, the GSL curved diffuser can still provide full horizontal airflow adjustment with the directional

control blade following the profile of the outer frame. This ensures that full horizontal or vertical airflow distribution can be achieved. All other details in terms of dimensions fixings and plenum boxes are as standard.

Opening Detail

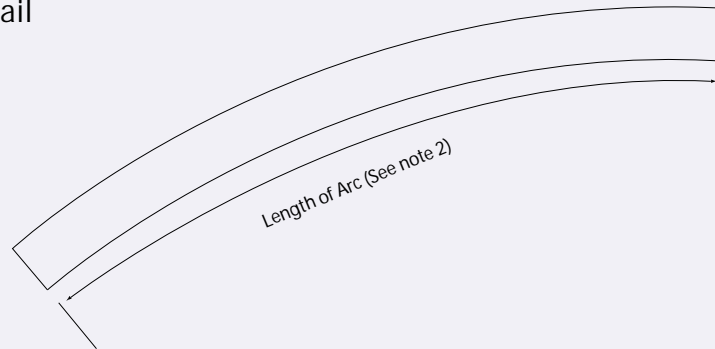

Notes

1. List radius is to inside edge of opening (min radius 3000mm)
2. List length is the arc length of the inside edge of the opening.
3. For joining sections together use fir tree studs and dowel pins as shown on Page 3
4. Maximum plenum box length as follows
 - over 15m radius: 1500
 - over 10m radius: 1000
 - over 7m radius: 600
5. Under 7m radius shaped boxes will be required.

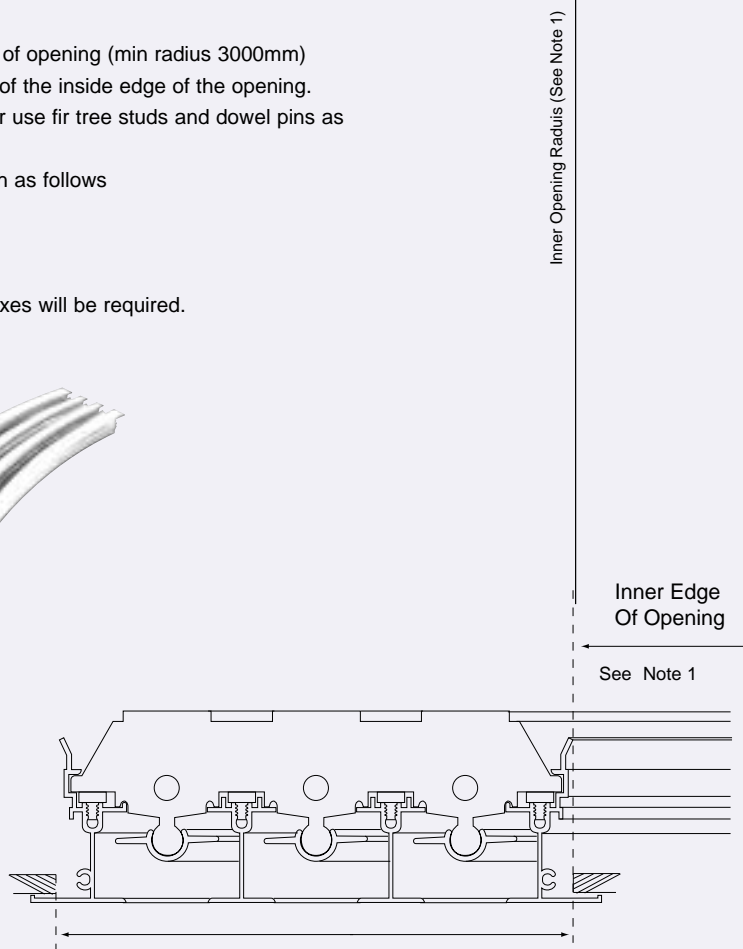

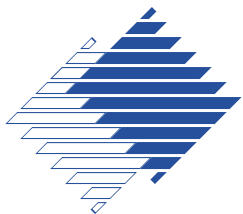

SERIES GSL

End Flanges and End Caps

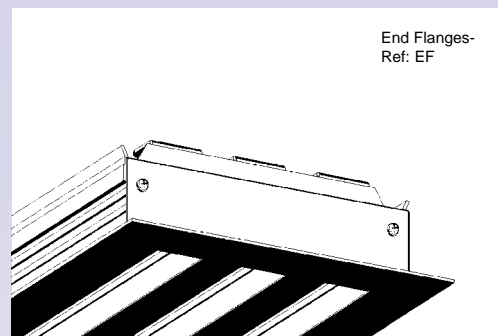
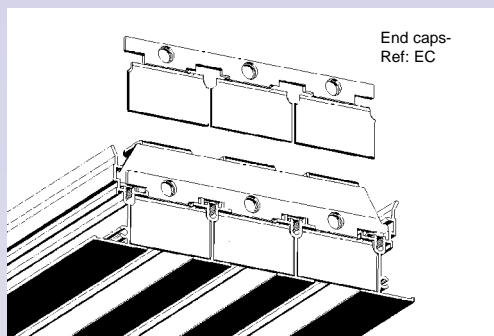

Fixing Options

The standard fixing option for the GSL slot diffuser is the popular concealed bracket fixing. The concealed brackets are fixed to the rear of the diffuser and quickly push fit into the plenum. Unclipping the diffuser blade allows access to the captive nuts on the brackets to tighten and align the unit in place.

Where access is easily available to the ceiling void an alternative fixing option is to simply drill through the neck of the diffuser and the plenum box and then rivet into place. This offers a unit cost saving over the standard concealed

bracket fixing arrangement but may take a little more time to install.

A further fixing option is offered in the form of a toggle latch clip. One of the quickest and easiest fixing options by far. The diffuser is simply located into the plenum and firmed up into place by pushing the toggle fixings into place.

For installations without a plenum the diffuser always automatically includes holes for standard drop rod support on the diffuser back straps. The back straps are spaced on approx. 300mm centres.

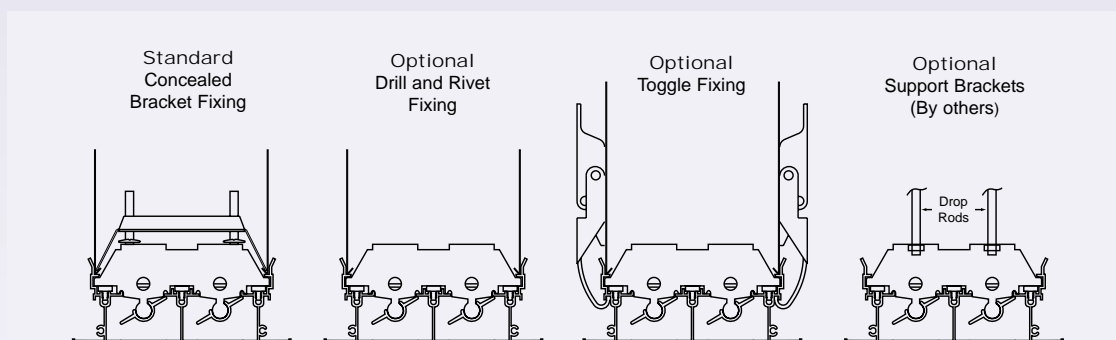

Blanking Plates

For inactive or dummy sections, matt black blanking plates can be supplied. Blanking plates are supplied in standard 150mm lengths and simply locate onto the back of the diffuser where they can be secured with standard self-tapping screws.

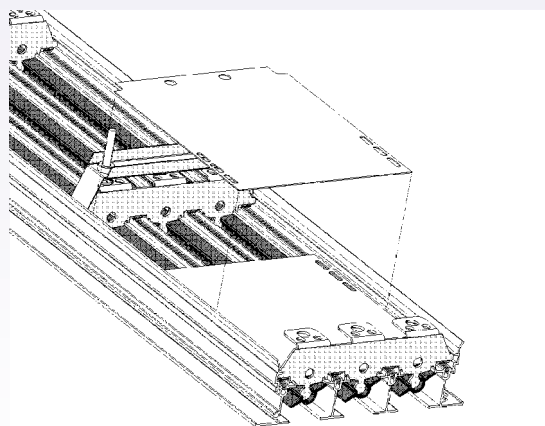

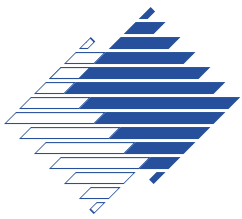

SERIES GSL

Plenum Box Series PB

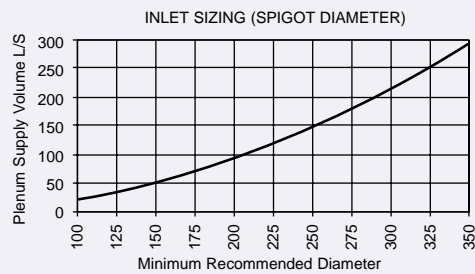
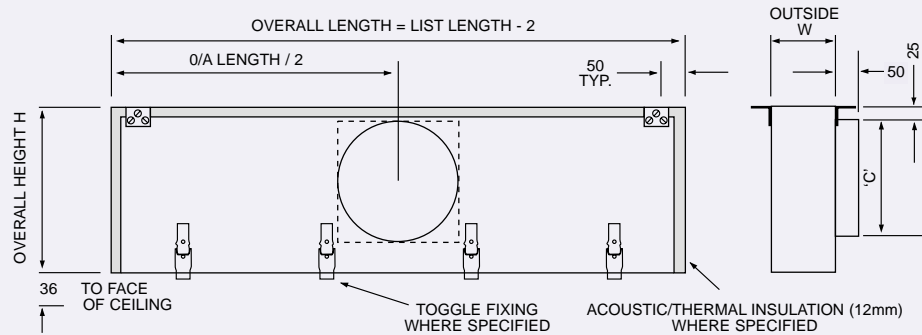

| No of Slots | Width W | Nominal Spigot Dia (or height) C | Standard Height H |
|-------------|---------|----------------------------------|-------------------|
| 1 | 53.5 | 100 | 220 |
| 2 | 96 | 125 | 220 |
| 3 | 138.5 | 150 | 262.5 |
| 4 | 181 | 160 | 262.5 |
| 5 | 223.5 | 200 | 305 |
| 6 | 266 | 250 | 347.5 |
| 7 | 308.5 | 300 | 390 |
| 8 | 351 | 350 | 432.5 |

For low noise levels one size larger is recommended

General Specification

0.7mm Galvanised or Zintec coated mild steel construction.

Spigot Construction: Standard sizes use plastic clip-in spigot.

Nonstandard, a sealed screw-in spigot.

Thermal Insulation: 12mm Pyrosorb foam approx. U-value $4.7 \text{ Wm}^{-2} \text{ k}^{-1}$

Volume Control Options

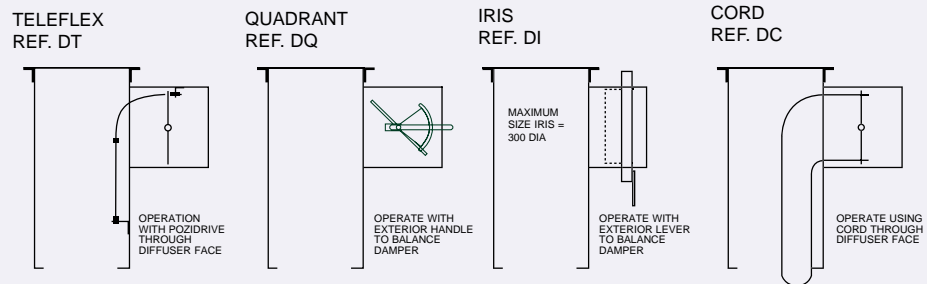

Spigot length = Spigot dia.

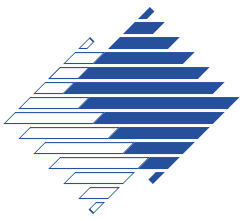

SERIES GSL

Sizing Nomogram: Horizontal Distribution

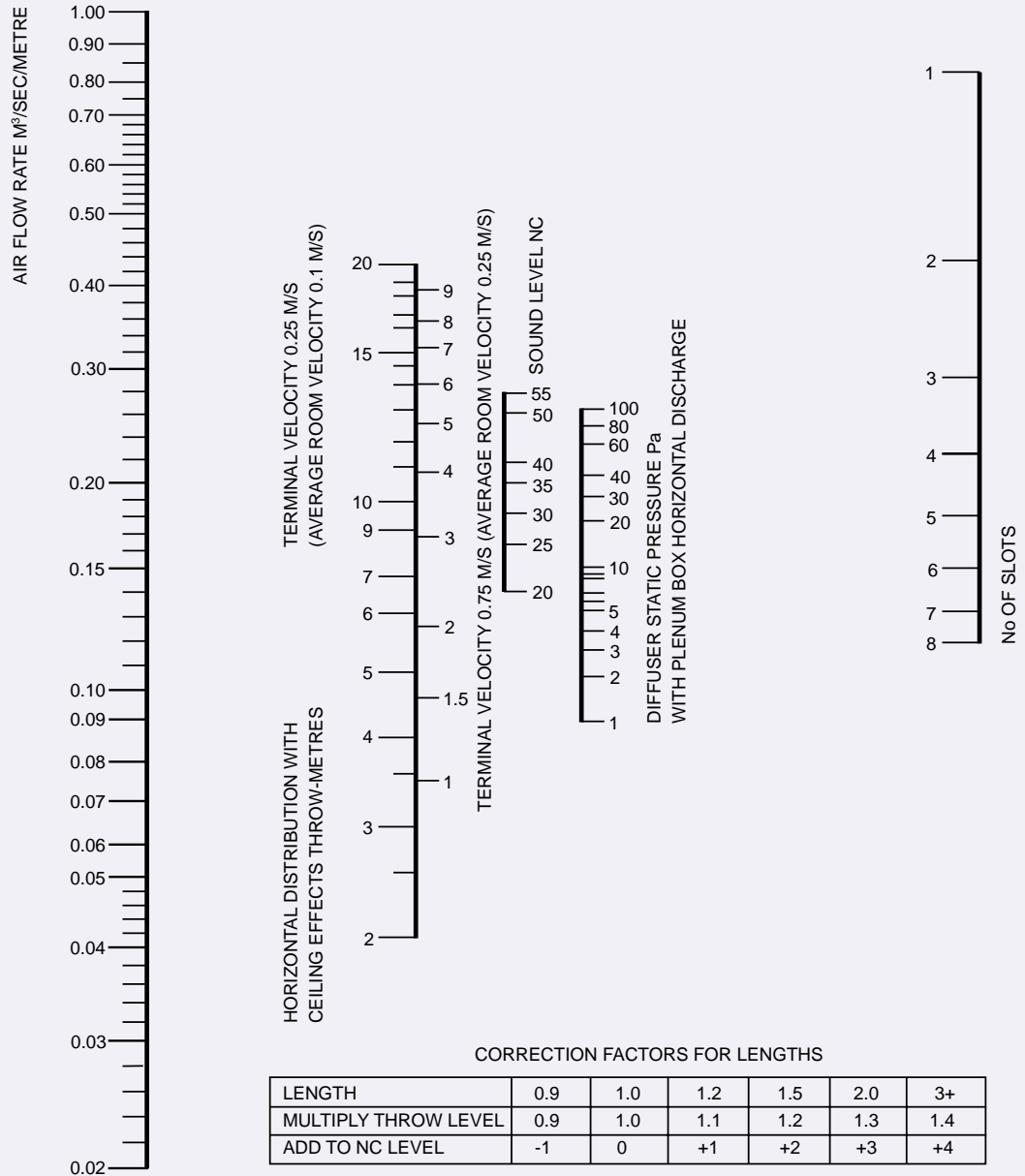

CORRECTION FACTORS FOR OTHER SUPPLY TEMPERATURES
 COOLING 10° Δt THROWS x 0.9
 HEATING 10° Δt THROWS x 1.15

ALL DATA BASED ON 1 METRE LONG DIFFUSER ISOTHERMAL
 CONDITIONS DAMPER FULL OPEN AND DIFFUSER FLUSH WITH CEILING
 BASED ON ROOM HEIGHT OF 2.8 METRES

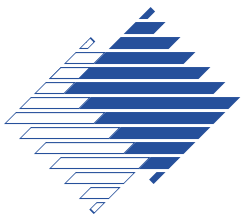

SERIES GSL

Sizing Nomogram: Vertical Distribution

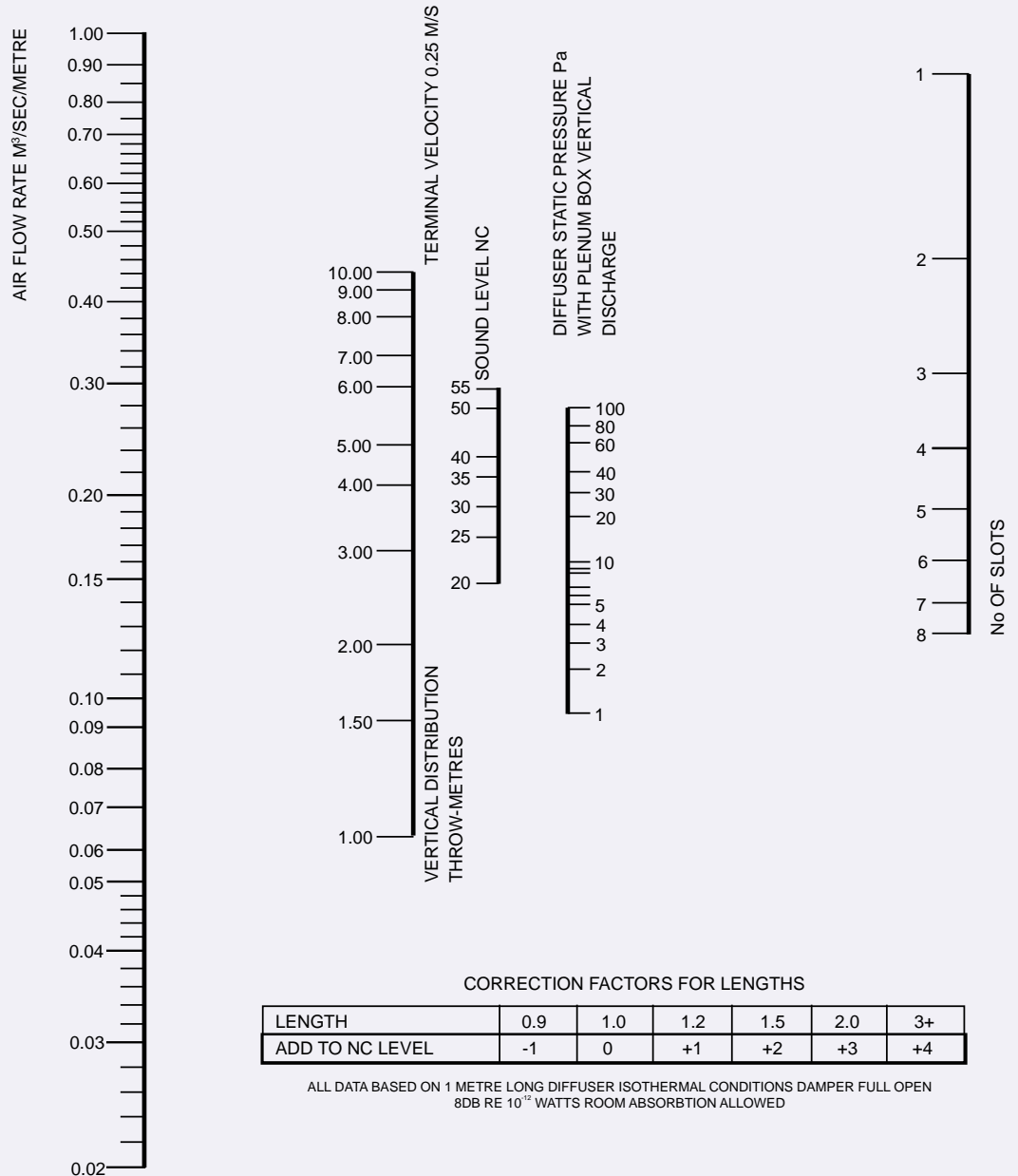

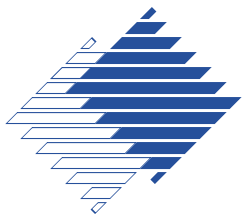

SERIES GSL

Ordering Specification (Diffuser)

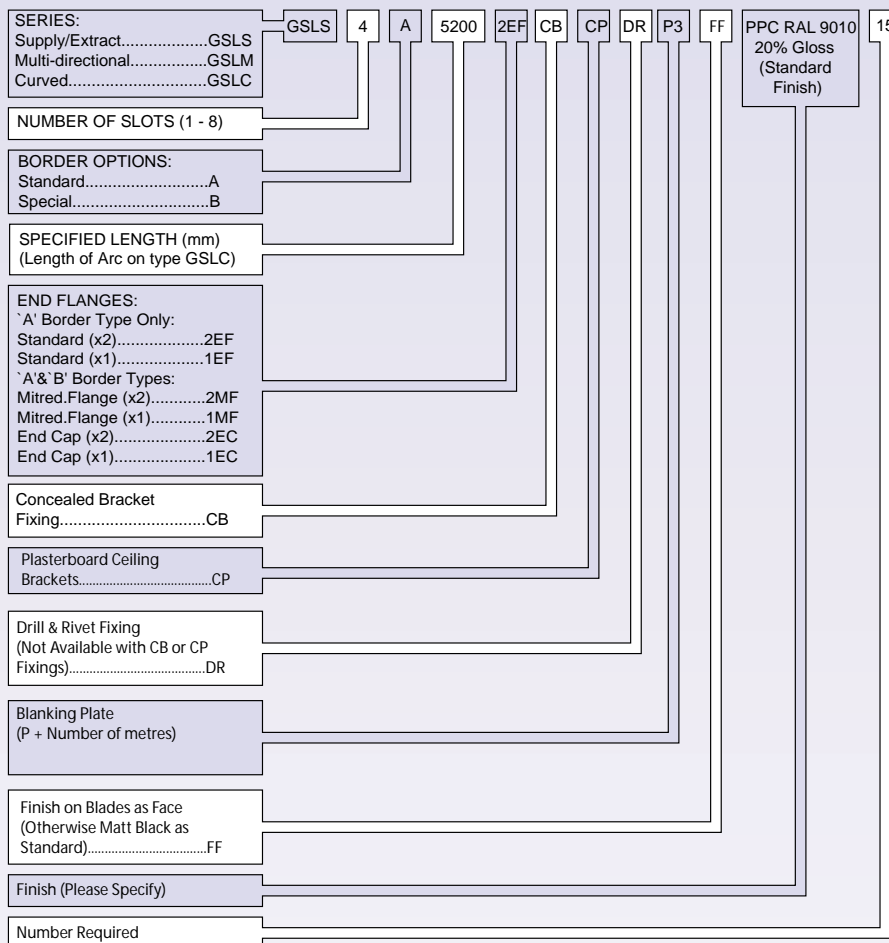

Fixing

Standard fixing options as listed. Fixings can be mixed and matched on long runs to suit the installation.

Support Brackets.....(SB): Always fitted. Used for units or lengths where no plenum box is fitted.

Concealed Brackets.....(CB): Standard for plenum box fixing

Plaster Ceiling Brackets...(CP): Std fixing for plaster ceiling installations.

Drill & Rivet.....(DR): Alternative to std CB option for plenum fixing.

Toggle Fixing.....(TF): Alternative to std CB option for plenum fixing (see plenum box ordering spec)

Blanking Plates

Screw fix matt black blanking plates available for dummy/inactive sections and are fitted to the back of the diffuser. Supplied in modular 150mm lengths.

Finish

Standard finish: Polyester powder coat white 20% gloss with internal blades matt black.

Special Finishes: Polyester powder finish to stock BS/RAL colour.
Stove enamel to any BS or RAL colour.

Internals: Matt black plastic blades for all finishes unless face finish option (FF) is specified.

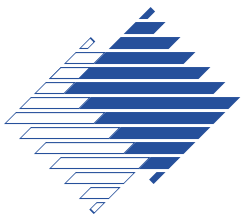

SERIES GSL

Ordering Specification (Plenum Boxes)

| | | | | | | | | | | | | |
|---|--------|---|----|------|-------|----|----|----|------------|-----|------------|----|
| SERIES.....PB/GSL | PB/GSL | 4 | AT | 1500 | BH500 | BB | PM | ST | DQ 250 Dia | TSO | DQ 250 Dia | 15 |
| NUMBER OF SLOTS (1 - 8) | | | | | | | | | | | | |
| Thermal/Acoustic Insulation: 12mm Pyro (Std).....AT1 25mm Pyro.....AT2 12mm Armaflex.....AT3 | | | | | | | | | | | | |
| SPECIFIED LENGTH (mm) | | | | | | | | | | | | |
| Box Height (Where Different From Standard) | | | | | | | | | | | | |
| Matt Black Internals Option: (if Thermal/Acoustic Insulation Not Required).....BB | | | | | | | | | | | | |
| Perforated Mesh.....PM | | | | | | | | | | | | |
| Fixing Arrangement: Standard.....ST Toggle Fix.....TF Plaster Ceiling.....PC | | | | | | | | | | | | |
| Single Spigot & Damper Options Plus Nominal Spigot Size*: No Damper.....SS+Size Quadrant.....DQ+Size Cord Operated.....DC+Size Teleflex.....DT+Size Iris.....DI+Size | | | | | | | | | | | | |
| Twin Spigot Options: Adjacent.....TSA Opposite.....TSO | | | | | | | | | | | | |
| Second Spigot & Damper Options Plus Nominal Spigot Size*: No Damper.....SS+Size Quadrant.....DQ+Size Cord Operated.....DC+Size Teleflex.....DT+Size Iris.....DI+Size | | | | | | | | | | | | |
| Number Required | | | | | | | | | | | | |

Thermal/Acoustic Insulation (AT1, AT2, and AT3)

Plenum box can be fully lined with 12mm (standard) or 25mm Pyrosorb thermal/acoustic insulation as well as 12mm Armaflex. No insulation lining is available on 1 slot plenums and 25mm thick insulation is not available on 2 slot plenums unless box is stepped out to accept the insulation lining thickness. Please check with office for dimensional information in these applications.

Perforated Mesh (PM)

Plenum fitted internally with 50% perforated Equalising mesh.

Spigot Options

Plenums can be supplied with either single or twin spigot inlets and mounted on the same, or opposite sides of the box. Each spigot can also be fitted with quadrant, cord, teleflex or iris dampers. Standard sizes use plastic clip in spigot. Non standard, a sealed screw in spigot.



SERIES GSL

Ordering Specification (Mitred Corner)

| | | | | | | |
|--|---------|---|---|----|---|----|
| SERIES: Supply / Extract MC/GSLS Multi-directional.....MC/GSLM | MC/GSLS | 4 | A | 80 | PPC RAL 9010 20% Gloss (Standard Finish) | 15 |
| NUMBER OF SLOTS (1 - 8) | | | | | | |
| BORDER OPTIONS: Standard.....A Special.....B | | | | | | |
| Internal Angle of Mitred Corner (90 Degrees as Standard) | | | | | | |
| Finish (Please Specify) | | | | | | |
| Number Required | | | | | | |

Note: All mitred corners supplied size 200x200 Internal length (see illustration on page 5).

Diffuser ordering specification: See Page 12.
Plenum Box ordering Specification: See Page 13

Contact

GILBERTS

Head Office and Works
GILBERTS (BLACKPOOL) LTD
Gilair Works, Clifton Road,
Blackpool.
Lancashire FY4 4QT.
Telephone: (01253) 766911
Fax: (01253) 767941
e-mail: sales@gilbertsblackpool.com
Web: www.gilbertsblackpool.com

Gilberts (Blackpool) Ltd reserve the right to alter the specification without notice. For our latest product data please visit www.gilbertsblackpool.com
The information contained in this leaflet is correct at time of going to press © 2008.

