

# SERIES GZL

High Induction

Linear

Diffuser

PATENTED

PUBLICATION

DIFFUSERS 9

AUGUST 2006



## Features

- One or Two Slot Design.
- High Induction Effect.
- Unique Crossflow Jet Air Distribution.
- Dynamic Modern Styling and Design.
- Comprehensive Series of Matching Plenums.
- Extruded Aluminium Construction.



# GILBERTS



# SERIES GZL

## Introduction

Gilberts GZL (Zipp-Air) Diffuser Series offers a new concept in linear air distribution technology. Combining innovative design and dynamic styling with excellent air distribution performance the Zipp-Air is a further development in the sphere of modern high induction diffuser design complementing Gilberts existing ceiling and floor swirl technology. Using its unique cross-flow design the units rapid air entrainment characteristics allow it to deliver high volumes of air into the conditioned zone whilst maintaining normal comfort levels, even with air change rates as high as 25.

Manufactured from extruded aluminium the GZL is available in one or two slot width configurations and is suitable for ceiling or side wall mounting. Single units can be supplied up to 1.5m in length with longer lengths supplied in sections and discreetly joined with a simple, effective alignment feature. The standard border detail comprises of a 27mm flange border with end flanges or end caps optionally available. However in keeping with modern ceiling design the series will be available with alternative border styles to match different popular ceiling types.

### STANDARD SERIES OPTIONS:

TYPE GZLA - Standard 27mm flange border Zipp-Air Diffuser suitable for drop-in ceiling grid and plaster ceiling application.

The GZL Series is complemented by a comprehensive range of purpose built plenum boxes. Manufactured from galvanised or zinc coated mild steel the boxes can be supplied to suit all diffusers in sectional box lengths up to 1500mm. Connection between the boxes and diffusers can be accomplished either by drill and rivet through the diffuser neck or, for an even faster installation, toggle latch fixings.

For installations without plenums, support brackets for drop rod fixings can be provided.

For volume control the standard plenum inlet can be fitted with quadrant or iris type dampers.

Standard finish on all GZL diffusers is white Polyester Powder, other colours and finishes available on request.

### Features

- One or two slot design.
- High induction effect.
- Unique crossflow jet air distribution.
- Dynamic modern styling and design.
- Comprehensive series of matching plenums.
- Extruded aluminium construction.



## Alignment Feature & Continuous Runs

For long diffuser runs a simple push fit alignment feature is provided for positive and accurate joining of individual diffuser lengths whilst maintaining an unbroken continuous appearance.

Quite simply a push pull spring clip can be snapped in to

each side of the diffuser end, both guiding and clipping the unit to the adjoining length. Additional alignment is also provided by fitting dowel pins into the end face locating into corresponding holes in the next section.

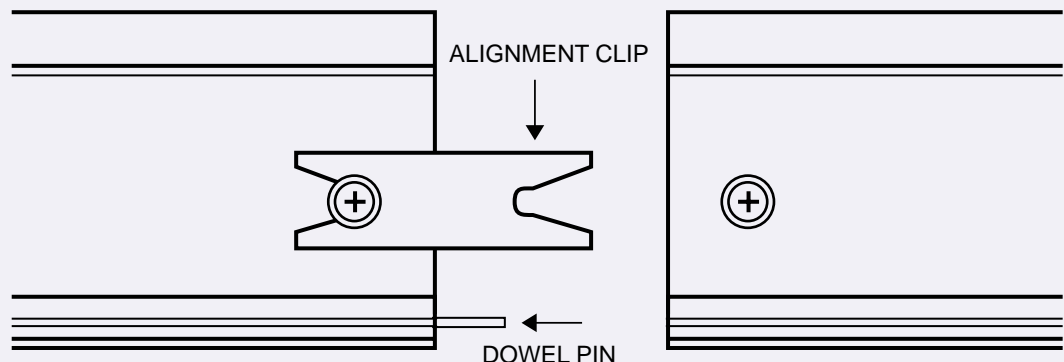

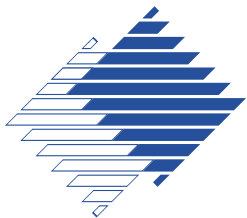

# SERIES GZL

## Semi Circular Air Distribution

The GZL Linear Slot Series Diffusers incorporate the unique 'Zipp-Air' cross-flow high induction jet design feature. This profile provides a semi circular air distribution pattern under the diffuser face which allows high induction mixing with the room air and a rapid fall off in discharge velocities. These air movement characteristics, difficult to achieve with existing conventional diffuser designs, mean that high air change rates can easily be accommodated within normal comfort condition parameters.

## Performance Data

The performance tables on the inside back cover of this brochure give performance data for each listed size of diffuser associated with specific volumes per metre length. Figures given relate to cooling and ventilation applications in a grid format on a cross-section of supply diffuser.

## Selection Procedure

**Note:** As the air distribution from this type of diffuser is of a semi-circular radial pattern, conventional directional air throw selection will not apply.

1. Establish the volume of air to be supplied to the conditioned space.
2. Knowing the type of space, refer to table one and establish the recommended maximum noise level for that type of area.
3. Divide the total air volume (m<sup>3</sup>/s) by the effective length of the diffuser and establish a volume per metre run. Note that the minimum spacing of two metres should be allowed between parallel lengths of diffusers.
4. Having established a volume per metre, check to see if it falls within the diffuser minimum to maximum range (see performance charts for one and two slots capacities). It is not recommended to reduce the volume per metre below the minimum value as the high entrainment feature is reduced and dumping of the supply air could occur.
5. Check to see that the maximum noise level is also not exceeded.
6. Establish the near field and average room air movement velocities from performance data tables.

### Examples:

0.8m<sup>3</sup>/s of supply air at a  $\Delta t$  of -5°C is to be supplied to a 6m x 6m x 2.8m high conditioned space.

Maximum noise level to be NC 35.

Select 3 x 6m lengths of slot diffuser evenly spaced across the ceiling at 1m from one wall to the first run, then 2m centres for the following 3 x 6m runs.

Total length of slot diffuser = 6 x 3 = 18m  
therefore 0.8m<sup>3</sup>/s divided by 18 = 0.044m<sup>3</sup>/s per metre run of diffuser.

From selection tables a 1m x 1 slot diffuser handling the above air volume would give an average room velocity in the occupied zone of 0.15m/s, and a noise level of NC 25. It is worth noting that this selection has achieved an air change rate throughout the occupied zone of 28 air changes per hour.

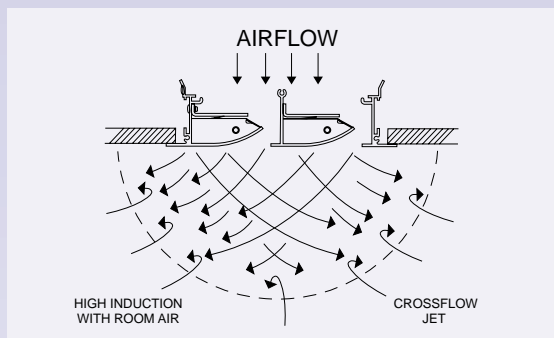

- PRESSURE - all pressures are in pascal's (n/m<sup>2</sup>)
- AIR VELOCITIES - all air stream velocities are given in m/s
- SOUND - the NC values are peak levels on the NC curves.

## PLENUM BOXES

Standard plenum box details are shown in the plenum box section and inlet sizing data. This provides the recommended minimum size of plenum box to obtain even distribution along the diffuser using one centre fed constant cross-section plenum box. If side entry inlet however cannot be accommodated, and only top entry is possible then all boxes should be complete with a perforated baffle section. Plenum boxes are available in lengths up to 1500mm and are suitable for direct fixing through the neck of the diffuser, or where specified toggle latch fixing. The plenum to diffuser connection offers tight and secure fitting and provides an adequate air seal. However, additional sealing may be applied on site if ultra low leakage is required.

TABLE 1

Area to be served	Recommended Maximum NC Levels
Sound Broadcasting	15 - 20
Recording Studios TV (Audience Studios)	20 - 25
Lecture Theatres, Cinemas, Concert Halls, Boardroom/Ex Offices Lounge, Conference Room, Court Room, Churches, Private Bedrooms	25 - 30
Operating Theatres, Hospital Wards, Staff Room, Class Rooms, Ballroom, Banquet Room, Library, Bank, Museum, Offices	30 - 40
Restaurants, Department Stores, Computer Suite, Washroom Toilet	35 - 40
Laundries, Kitchens, Swimming Pools, Sports Arena	40 - 45
Garage, Light Engineering Workshop	45 - 50
Heavy Engineering Workshop	50 - 65



# SERIES GZL

## Dimensional Details GZLA

### ONE SLOT

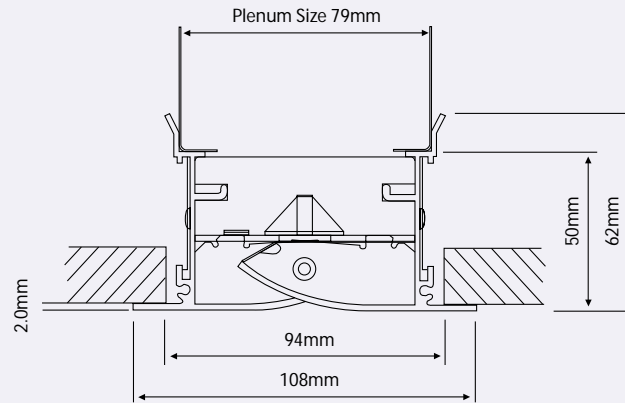

### TWO SLOT

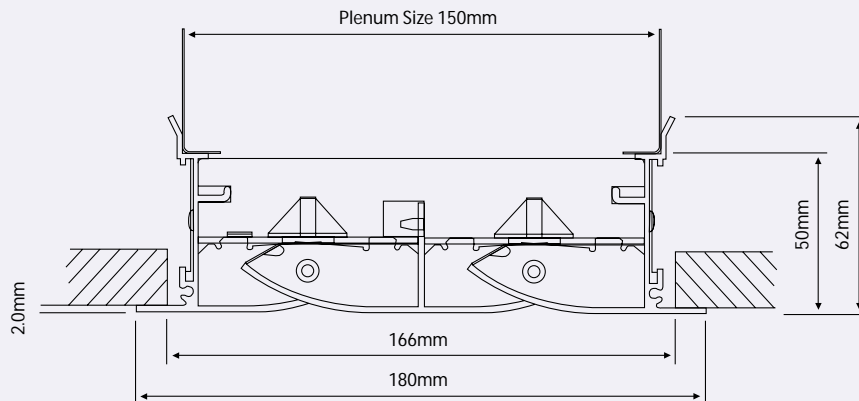

### UNIT WITH END CAPS

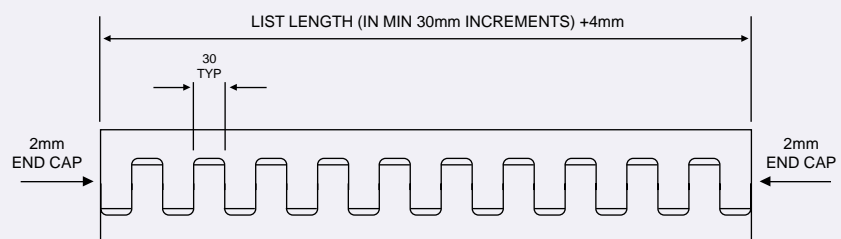

### UNIT WITH END FLANGES

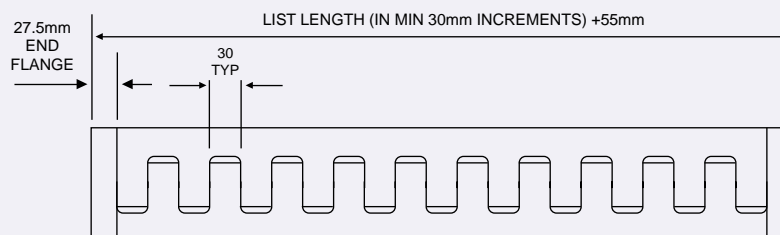

**Note:** End flange dimension can be reduced anywhere down to 3mm if required to achieve a specific length overall

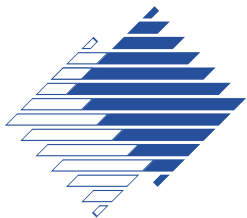

# SERIES GZL

## Plenum Box Series PB

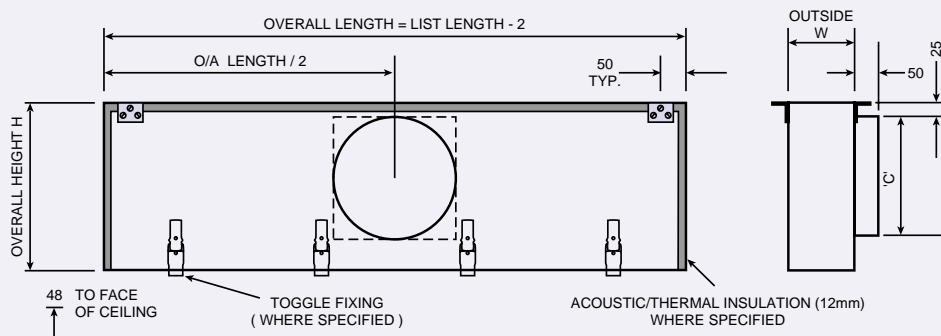

SPIGOT DIAMETER SELECTION

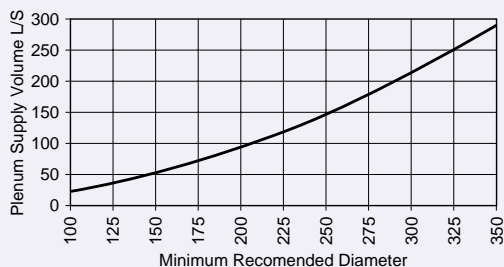

No of Slots	Width W
1	79
2	150

Nominal Spigot Dia (or height) C	Standard Height H
100	220
125	220
150	262.5
160	262.5
200	305
250	347.5
300	390

0.7 Galvanised or Zintec coated mild steel plenum.  
 Spigot Construction: Standard size spigots use plastic clip-in spigots.  
 Non standard, a sealed screw-in steel spigot  
 Thermal insulation: 12mm Pyrosorb foam approx. U-value  $4.7 \text{ Wm}^{-2}\text{k}^{-1}$

## Volume Control Options

QUADRANT REF. DQ

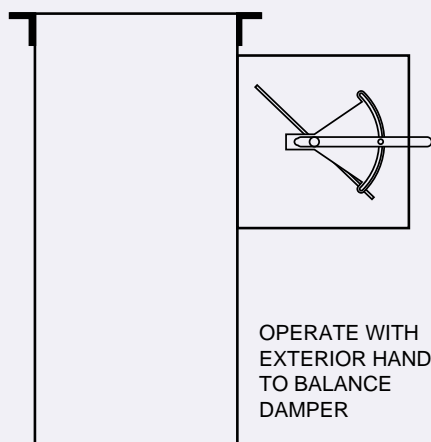

IRIS REF. DI

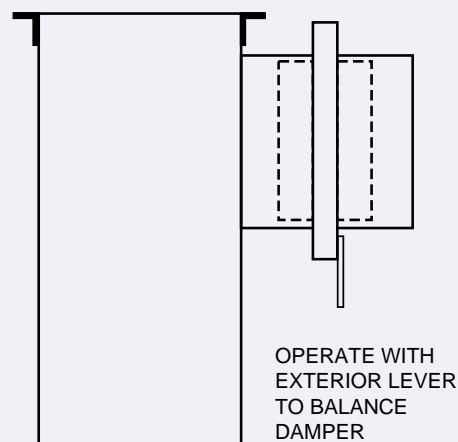



# SERIES GZL

## Fixing Options

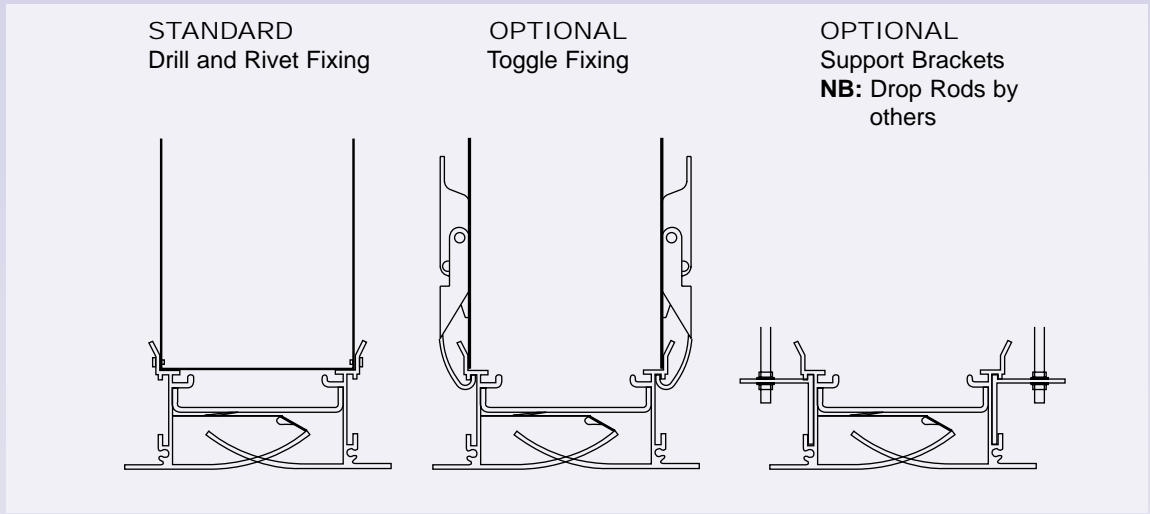

## Technical Data

### PERFORMANCE GRID

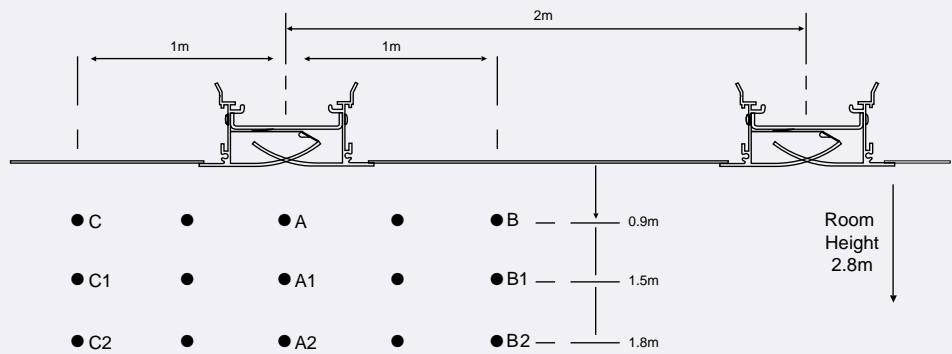

## Pressure Data

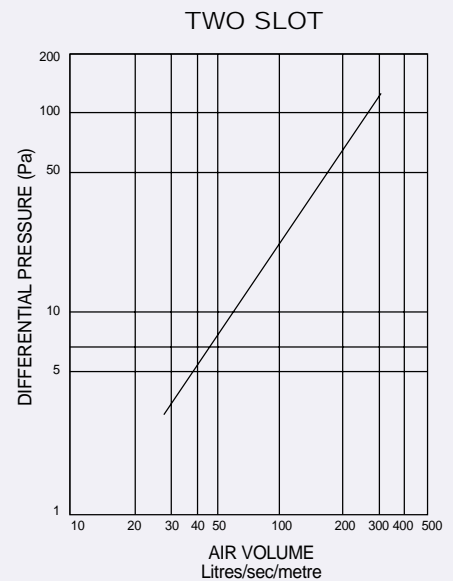
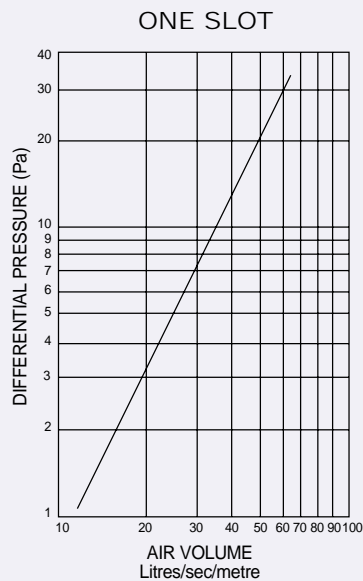



# SERIES GZL

1 Slot ( $\Delta t$ - OK)											
AIR VOLUME PER METRE (L/S)	VELOCITIES (M/S)									ROOM AVER IN OC ZONE M/S	N.C. LEVEL N.C.
	A	A1	A2	B	B1	B2	C	C1	C2		
20	0.10	0.01	0.10	0.14	0.05	0.01	0.16	0.05	0.12	0.06	15
30	0.13	0.01	0.09	0.16	0.07	0.02	0.13	0.05	0.09	0.07	15
40	0.17	0.01	0.01	0.19	0.13	0.15	0.24	0.07	0.12	0.11	20
50	0.24	0.12	0.15	0.23	0.10	0.13	0.17	0.07	0.10	0.12	35
60	0.18	0.15	0.10	0.12	0.16	0.10	0.20	0.03	0.15	0.15	40

1 Slot ( $\Delta t$ - 5K)											
AIR VOLUME PER METRE (L/S)	VELOCITIES (M/S)									ROOM AVER IN OC ZONE M/S	N.C. LEVEL N.C.
	A	A1	A2	B	B1	B2	C	C1	C2		
20	0.04	0.12	0.04	0.14	0.14	0.09	0.08	0.09	0.15	0.11	15
30	0.19	0.06	0.04	0.11	0.10	0.01	0.22	0.08	0.07	0.14	15
40	0.08	0.16	0.20	0.16	0.09	0.01	0.11	0.09	0.11	0.15	20
50	0.11	0.12	0.08	0.17	0.10	0.10	0.17	0.13	0.11	0.16	35
60	0.11	0.13	0.15	0.20	0.15	0.11	0.21	0.17	0.21	0.17	40

1 Slot ( $\Delta t$ - 10K)											
AIR VOLUME PER METRE (L/S)	VELOCITIES (M/S)									ROOM AVER IN OC ZONE M/S	N.C. LEVEL N.C.
	A	A1	A2	B	B1	B2	C	C1	C2		
20	0.21	0.13	0.08	0.05	0.11	0.11	0.17	0.16	0.04	0.16	15
30	0.12	0.15	0.15	0.11	0.09	0.14	0.10	0.24	0.19	0.17	15
40	0.19	0.21	0.04	0.15	0.22	0.12	0.18	0.23	0.10	0.19	20
50	0.18	0.11	0.15	0.17	0.15	0.12	0.23	0.15	0.07	0.20	35
60	0.22	0.26	0.15	0.22	0.16	0.22	0.26	0.21	0.17	0.24	40

2 Slot ( $\Delta t$ - 0K)											
AIR VOLUME PER METRE (L/S)	VELOCITIES (M/S)									ROOM AVER IN OC ZONE M/S	N.C. LEVEL N.C.
	A	A1	A2	B	B1	B2	C	C1	C2		
60	0.02	0.01	0.01	0.01	0.01	0.01	0.01	0.01	0.01	0.2	15
80	0.08	0.01	0.03	0.07	0.03	0.01	0.07	0.01	0.01	0.04	20
100	0.10	0.02	0.04	0.06	0.05	0.06	0.12	0.06	0.05	0.05	30
120	0.08	0.08	0.01	0.08	0.08	0.05	0.07	0.08	0.01	0.06	35
140	0.08	0.03	0.06	0.08	0.08	0.08	0.12	0.08	0.08	0.07	40
160	0.07	0.08	0.06	0.12	0.08	0.07	0.09	0.08	0.12	0.08	45

  

2 Slot ( $\Delta t$ - 5K)											
AIR VOLUME PER METRE (L/S)	VELOCITIES (M/S)									ROOM AVER IN OC ZONE M/S	N.C. LEVEL N.C.
	A	A1	A2	B	B1	B2	C	C1	C2		
60	0.23	0.05	0.17	0.17	0.08	0.08	0.17	0.01	0.09	0.11	15
80	0.14	0.05	0.15	0.22	0.12	0.11	0.19	0.11	0.08	0.13	20
100	0.19	0.13	0.15	0.17	0.10	0.15	0.13	0.17	0.16	0.15	30
120	0.14	0.16	0.20	0.17	0.21	0.10	0.14	0.24	0.22	0.17	25
140	0.18	0.20	0.25	0.19	0.16	0.18	0.23	0.15	0.24	0.19	40
160	0.15	0.17	0.26	0.40	0.12	0.14	0.45	0.09	0.20	0.22	45

2 Slot ( $\Delta t$ - 10K)											
AIR VOLUME PER METRE (L/S)	VELOCITIES (M/S)									ROOM AVER IN OC ZONE M/S	N.C. LEVEL N.C.
	A	A1	A2	B	B1	B2	C	C1	C2		
60	0.27	0.18	0.16	0.13	0.08	0.08	0.14	0.07	0.14	0.13	15
80	0.27	0.13	0.11	0.11	0.12	0.22	0.12	0.14	0.14	0.15	20
100	0.22	0.20	0.20	0.13	0.19	0.17	0.34	0.18	0.15	0.18	30
120	0.29	0.25	0.26	0.32	0.10	0.21	0.28	0.20	0.28	0.25	35
140	0.22	0.15	0.20	0.59	0.51	0.48	0.60	0.30	0.31	0.37	40
160	0.23	0.23	0.27	0.60	0.43	0.36	0.66	0.50	0.41	0.41	45

NC. VALUES BASED ON ROOM ABSORPTION of 8db

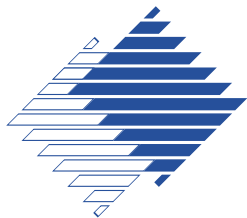

# SERIES GZL

## Ordering Specification Diffuser

SERIES .....	GZL	GZL	2	5200	1EF	SB	P3	PPC RAL 9010 20% GLOSS (STANDARD FINISH)	15
NUMBER OF SLOTS (1 or 2)									
LIST LENGTH (30mm Increments)									
END FLANGES									
Standard (x2) .....	2EF								
Standard (x1) .....	1EF								
End Caps (x2) .....	2EC								
End Caps (x1) .....	1EC								
FIXING OPTIONS: SUPPORT BRACKETS (for installation without plenum).... SB CONCEALED BRACKET (on GZL/2 only) .....	CB								
BLANKING PLATE (P + No of Metres)									
FINISH (Please Specify)									
NUMBER REQUIRED									

## Plenum

TYPE REQUIRED.....PB/GZL	PB/GZL	2	AT1	5200	250H	BB	PM	DR	DQ250DA	TSA	DQ250DA	15
NUMBER OF SLOTS (1 or 2)												
THERMAL / ACOUSTIC INSULATION (SEB ONLY)												
12mm PYRO (Standard) .....	AT1											
25mm PYRO .....	AT2											
12mm Armaflex .....	AT3											
LIST LENGTH (mm)												
BOX HEIGHT (If different from standard)												
MATT BLACK INTERNALS OPTION: .....	BB											
PERFORATED MESH.....PM												
FIXING ARRANGEMENT :												
Drill & Rivet (Std) .....	DR											
Toggle Fix.....	TF											
Concealed Bracket.....	CB											
SPIGOT AND DAMPER OPTIONS: (Plus Nominal Spigot Size) :												
No Damper.....	SS + Size											
Quadrant.....	DQ + Size											
Iris.....	DI + Size											
TWIN SPIGOT OPTIONS:												
Adjacent.....	TSA											
Opposite.....	TSO											
2nd SPIGOT AND DAMPER OPTION (See Damper Option)												
NUMBER REQUIRED												

### FIXING

Standard fixing is drill and rivet through the plenum into the diffuser neck. Toggle latch plenum fixing is also available on request.

For installations without a plenum, support brackets can be selected.

### FINISH

**Standard finish:** PPC White RAL 9010  
20% gloss

**Special Finishes:** PPC to stack BS or RAL colour; Stove Enamel to any BS or RAL colour.

## Contact

### GILBERTS

Head Office and Works  
**GILBERTS (BLACKPOOL) LTD**  
Gilair Works, Clifton Road,  
Blackpool.  
Lancashire FY4 4QT.  
Telephone: (01253) 766911  
Fax: (01253) 767941  
e-mail: sales@gilbertsblackpool.com  
Web: www.gilbertsblackpool.com

