

SERIES PG

Perforated Face Diffuser

PUBLICATION

DIFFUSERS 4

APRIL 2007

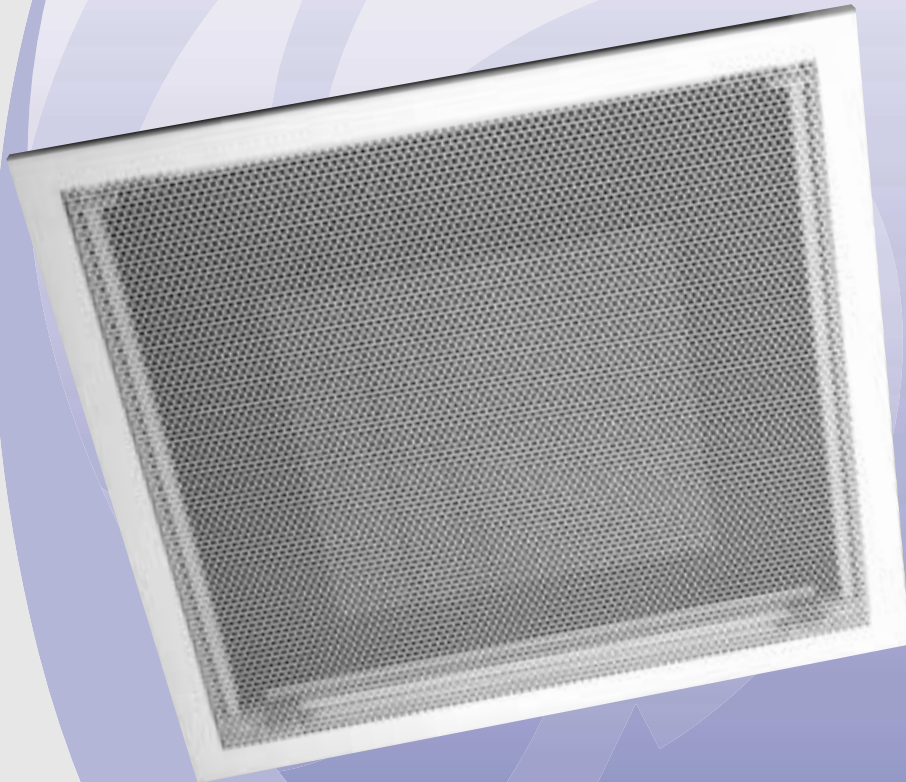

Features

- Concealed Deflection. for 1, 2, 3 or 4 Way Throw.
- Air Pattern Adjustable Core Option
- Hinged Opening Fascia for Access and Cleaning.
- Quiet, even Air Distribution.
- Top and Side Entry Connection.
- Extruded Aluminium frame with Steel Fascia.



GILBERTS

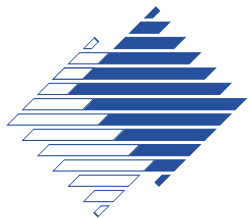

SERIES PG

Introduction

The PG Series of perforated diffusers provides a modern yet discreet range of diffusers designed to blend effectively with modern ceiling styles and profiles. Offering excellent uniform air distribution patterns the unit comprises of an extruded aluminium frame with a perforated, 50% free area, steel fascia. Concealed behind the fascia, on supply units, are factory fitted air deflection cassettes configured to give a 1, 2, 3 or 4 way discharge as required. Alternatively units can also be specified with a multi directional cassette which allows on site adjustment to any of the standard air patterns. Exhaust units are supplied without cassettes.

Conveniently the diffuser face incorporates a double hinge mechanism which allows for easy access to internals both for cleaning and for damper, or cassette, setting and adjustment.

SERIES OPTIONS:

PG 1, 2, 2E, 3 or 4 way Perforated Face Supply Diffuser complete with air deflection feature and top entry plenum connection box.

PG-R Perforated Face Extract Diffuser without air deflection feature or plenum box.

Features

- Concealed deflection vanes for 1, 2, 3 or 4 way throw.
- Air Pattern Adjustable Core Option
- Hinged opening fascia for access and cleaning.
- Quiet, even air distribution.
- Top or side entry connection.
- Extruded aluminium frame with steel fascia.

Standard list sizes range from 227mm to 527mm square with overall sizes to match popular ceiling grids. All supply units are fitted with a top entry connection box with a variety of inlet size options for optimum air distribution performance. Side entry boxes are also available as an optional extra.

Standard volume control is available using a screwdriver operated opposed blade (extract) damper or a rotary damper (supply) fitted at the diffuser neck. Damper adjustment and setting is achieved by lowering the hinged fascia for straightforward access. Quadrant operated spigot dampers can also be fitted to the plenum inlet where side entry boxes are selected.

The standard diffuser finish is polyester powder white with matt black internals. Other colours and finishes available on request.



Selection Procedure

Having established the position where air terminals can be located, select the required number of air directions per diffuser. Knowing the volume and throw for each diffuser in question then check:

(a) Recommended limit of volume per

direction with the throw of air required lying between the max. and min. values.

(b) Note sound level from performance data.

(c) Determine the pressure drop

from the performance data charts.

* For applications deviating from standard sizes or data, please contact our technical department.

Performance Data

The performance data tables on pages 7, 8 & 9 are information for cooling, ventilation and heating applications. They are intended to be aids to heating and air conditioning engineers.

REFERENCES USED

- **PRESSURE** All pressures are in Pa (N/m²)
SP = Static Pressure
-SP = Negative Static Pressure
- **THROW** The first figure is the throw that corresponds to 0.5m/s, and the second figure is the throw that corresponds to 0.25m/s.
- **SOUND** The NC values are based on a hard room with limited absorption and for one diffuser.

NOTE: For 3 way blow diffusers the pressures and noise levels are the same as 1, 2 and 4 way units for the same Total

air volume. To use the sizing tables for 3 way blow take the total air volume and use the 4 way charts to obtain throws for 2 directions. Use this same volume to obtain the throw for the last direction from the 2 way tables.

EXAMPLE:

Volume per diffuser = 0.156 M³/S (Supply, Inlet size 315 dia)
From 4 way blow tables

Throws in directions 'A' = 3 metres to 0.25 m/s Isothermal
From 2 way blow tables

Throw in direction 'B' = 6 metres to 0.25 m/s Isothermal

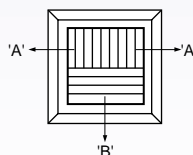

The performance data for all Gilberts products is derived using a Gilberts plenum design and specification. Performance cannot be guaranteed where alternative plenum designs are used.



SERIES PG

Series PG (Supply)

SERIES PG - TOP ENTRY
Supply

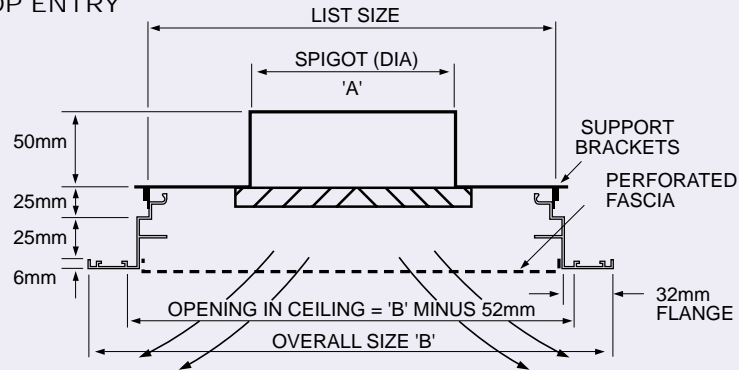

Supply Diffuser
c/w Rotary Damper

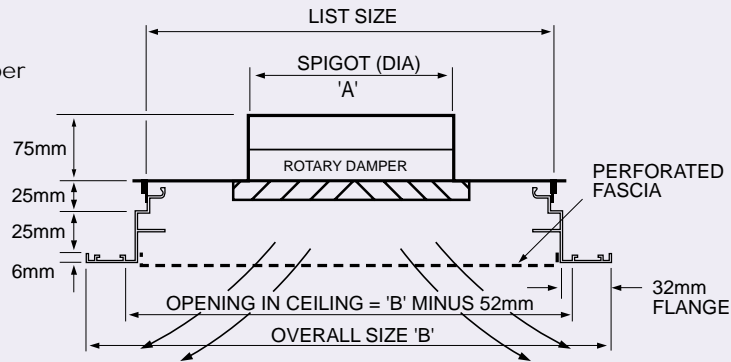

List Size	A Spigot Size (Dia)	B Overall Size	C Face Size (Type PGT)
227 x 227	160	299 x 299	
327 x 327	160 200	399 x 399	
422 x 422	160 200 250	494 x 494	484 x 484
427 x 427	160 200 250	499 x 499	
522 x 522	160 200 250 315	594 x 594	584 x 584
527 x 527	160 200 250 315	599 x 599	

Spigot Connections are male ie: outside size = A - 3mm

Series PGT Tegular Ceiling

The PG-T option for the perforated diffuser features a border frame specially designed to suit modern 'tegular' type ceiling grids. This border, available on supply 1, 2, 3 or 4 way units as well as extract models, features a factory adjusted edge detail to suit drops of between 7 - 19mm allowing it to match with most popular ceiling types (please provide full ceiling details).

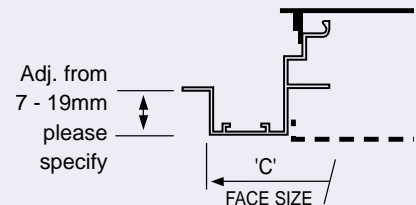

Series PGB Clip-in Ceiling

The PG-B option for the perforated diffuser features a border frame specially designed to suit popular clip-in type ceiling grids. Simply specify the ceiling pip height (normally 19 or 25mm) or provide full details of ceiling and we will include appropriate location/alignment clips to suit.

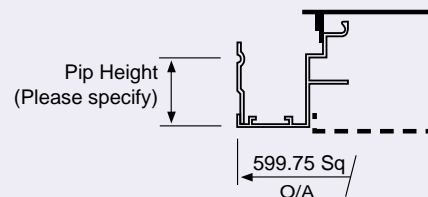



SERIES PG

Series PG (Supply)

SERIES PG/SEB - SIDE ENTRY Supply

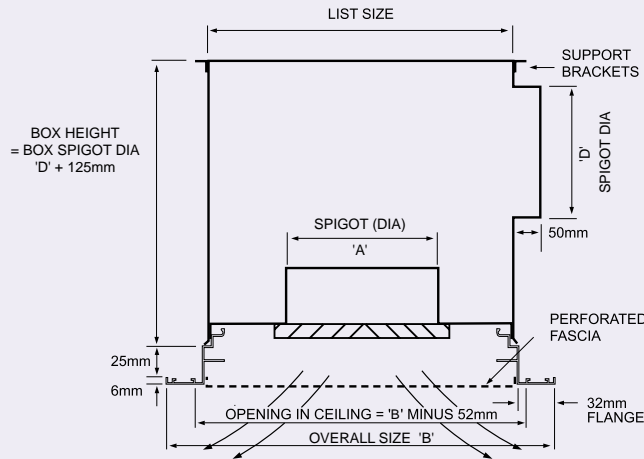

Quadrant Damper Option Inlet Spigot

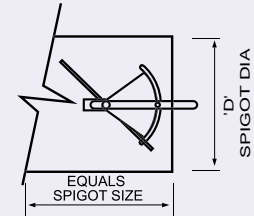

Note: Spigot Connections are male ie: outside size = A - 3mm

List Size	A Spigot Size (Dia)	B Overall Size	C Face Size (Type PGT)
227 x 227	160	299 x 299	
327 x 327	160 200	399 x 399	
422 x 422	160 200 250	494 x 494	484 x 484
427 x 427	160 200 250	499 x 499	
522 x 522	160 200 250 315	594 x 594	584 x 584
527 x 527	160 200 250 315	599 x 599	

Series PG (Extract)

SERIES PG - R Exhaust Diffuser

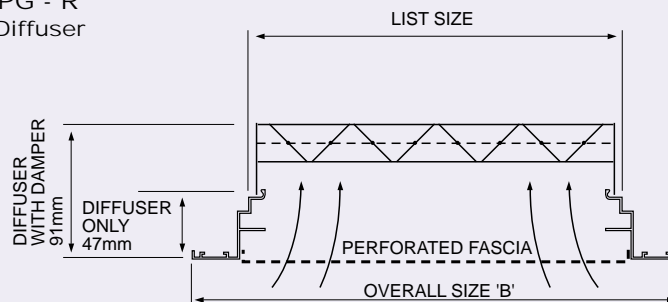

List Size	B Overall Size	C Face Size (Type PGT)
227 x 227	299 x 299	
327 x 327	399 x 399	
422 x 422	494 x 494	484 x 484
427 x 427	499 x 499	
522 x 522	594 x 594	584 x 584
527 x 527	599 x 599	

Note: Spigot Connections are male ie: outside size = A - 3mm



SERIES PG

Series PG (Extract)

SERIES PG - R - TCB Exhaust Diffuser c/w Top Connection Box

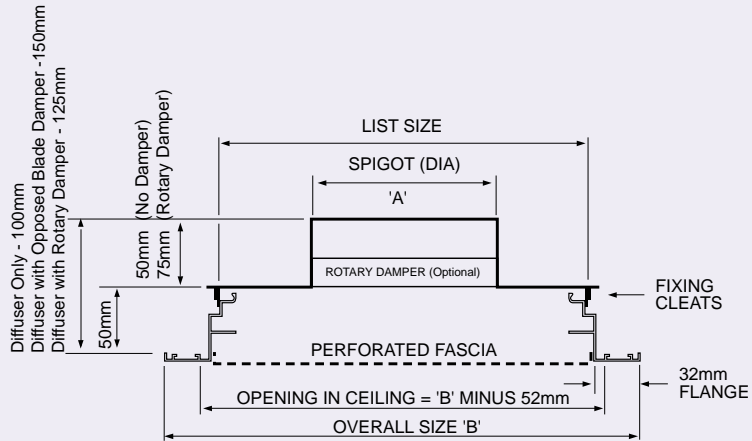

SERIES PG - R SEB Exhaust Diffuser c/w Side Entry Box

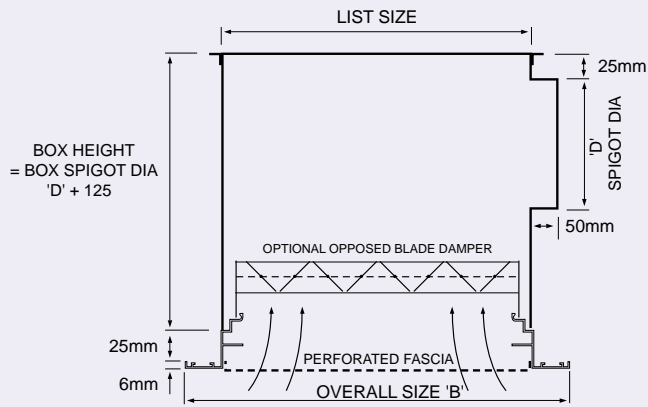

Quadrant Damper Option Outlet Spigot

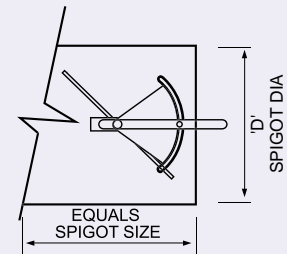

List Size	A Spigot Size (Dia)	B Overall Size	C Face Size (Type PGT)
227 x 227	160	299 x 299	
327 x 327	160 200	399 x 399	
422 x 422	160 200 250	494 x 494	484 x 484
427 x 427	160 200 250	499 x 499	
522 x 522	160 200 250 315	594 x 594	584 x 584
527 x 527	160 200 250 315	599 x 599	

Note: Spigot Connections are male ie: outside size = A - 3mm

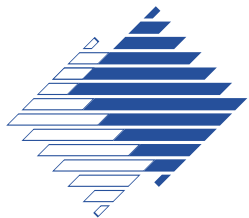

SERIES PG

Air Pattern Cassettes

To ensure correct air pattern control and air distribution performance all Series PG supply units are fitted with air deflection cassettes. On standard 1, 2, 3 and 4 way units a single cassette provides the air pattern and therefore cannot be reset to other patterns on site. The Multi Direction (MD) pattern however comprises 4 cassettes which does allow on site adjustment to a 1, 2 3 or 4 way air pattern as required. Access to the air pattern cassettes is achieved by opening the hinged diffuser face (see opening instructions below). This gives clear access to the cassettes which can simply be unscrewed and repositioned as required

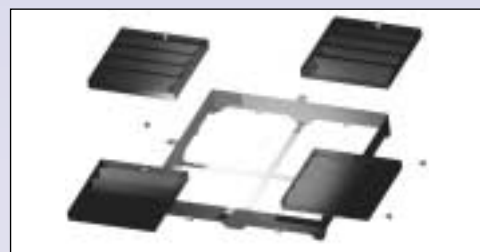

Rotary Dampers

The Rotary damper is a new alternative to fitting a quadrant damper on the plenum inlet allowing damper adjustment from the diffuser face. The damper can simply be manually adjusted/rotated to the required position using the tabs on the damper face.

For access to the damper the hinged diffuser face must first be opened (see opening instructions below) and the air pattern cassettes must then be removed. The Air pattern cassettes are easily unscrewed and dropped out for damper adjustment.

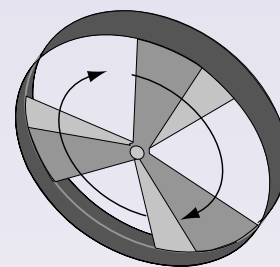

Hinged Access Feature

The perforated fascia on all PG Series diffusers is hinged to allow easy access to the dampers for adjustment and setting or for access to internals for cleaning.

Opening Instructions (see illustration)

- 1 Pull down to disengage spring clips only until perforated face is clear of frame, ie: 20mm
- 2 Move face forward by 10mm to allow the hinge side of the fascia to clear the diffuser frame before lowering any further.
- 3 Once the fascia is safely clear of the frame continue the downward movement to the open position.

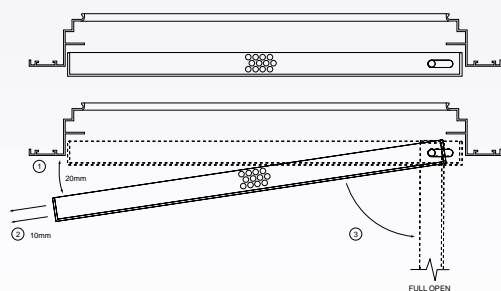

Air Pattern Options

PG1

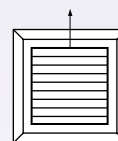

1 way

PG 2

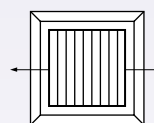

2 way

PG 2E

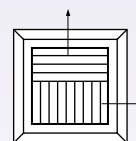

2 way corner

PG3

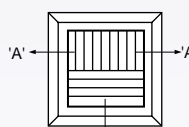

3 way

PG 4

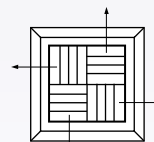

4 way

PG R

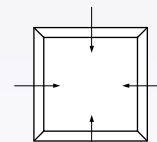

Extract



SERIES PG

Inlet Size
160 Dia

1 Way Blow

Volume flow rate (M ³ /S)	0.02	0.03	0.04	0.05	0.06
Pressure drop SP (top or side entry) (Pa)	4	7	10	16	25
Δt +10	0.7	1.2	1.5	2.0	2.5
Δt +5	0.6	1.0	1.3	1.7	2.2
Throw to 0.50 m/s Isothermal (M)	0.5	0.9	1.1	1.5	2.0
Δt -5	0.4	0.7	0.8	1.2	1.6
Δt -10	0.3	0.5	0.6	0.9	1.2
Δt +10	1.3	2.8	4.0	5.2	6.4
Δt +5	1.2	2.4	3.5	4.6	5.6
Throw to 0.25 m/s Isothermal (M)	1.0	2.1	3.0	4.0	4.8
Δt -5	0.8	1.6	2.4	3.2	3.8
Δt -10	0.6	1.2	1.8	2.4	2.8
Noise level (top or side entry) (NC)	15	20	20	25	35

4 Way Blow

Volume flow rate (M ³ /S)	0.02	0.03	0.04	0.05	0.06
Pressure drop SP (top or side entry) (Pa)	4	7	10	16	25
Δt +10	N/A	N/A	N/A	0.5	0.7
Δt +5	N/A	N/A	N/A	0.4	0.6
Throw to 0.50 m/s Isothermal (M)	N/A	N/A	N/A	0.3	0.5
Δt -5	N/A	N/A	N/A	0.2	0.4
Δt -10	N/A	N/A	N/A	0.2	0.3
Δt +10	N/A	0.4	0.6	1.0	1.2
Δt +5	N/A	0.3	0.5	0.9	1.1
Throw to 0.25 m/s Isothermal (M)	N/A	0.2	0.4	0.8	1.0
Δt -5	N/A	0.2	0.3	0.6	0.8
Δt -10	N/A	0.2	0.2	0.4	0.6
Noise level (top or side entry) (NC)	15	20	20	25	35

1 Way Blow

Volume flow rate (M ³ /S)	0.031	0.047	0.062	0.078	0.094
Pressure drop SP (top or side entry) (Pa)	3	8	15	24	36
Δt +10	1.0	1.5	1.8	2.4	2.9
Δt +5	0.9	1.3	1.5	2.1	2.5
Throw to 0.50 m/s Isothermal (M)	0.8	1.1	1.3	1.8	2.2
Δt -5	0.7	0.8	1.0	1.4	1.8
Δt -10	0.6	0.6	0.8	1.0	1.3
Δt +10	1.4	3.8	4.6	5.5	8.0
Δt +5	1.3	3.3	4.0	4.8	7.0
Throw to 0.25 m/s Isothermal (M)	1.2	2.8	3.5	4.2	6.0
Δt -5	1.0	2.1	2.8	3.3	4.8
Δt -10	0.8	1.6	2.0	2.5	3.5
Noise level (top or side entry) (NC)	15	20	25	35	40

2 Way Blow

Volume flow rate (M ³ /S)	0.02	0.03	0.04	0.05	0.06
Pressure drop SP (top or side entry) (Pa)	4	7	10	16	25
Δt +10	0.3	0.8	1.0	1.2	1.3
Δt +5	0.2	0.7	0.9	1.0	1.2
Throw to 0.50 m/s Isothermal (M)	0.2	0.6	0.8	0.9	1.0
Δt -5	0.2	0.4	0.6	0.7	0.8
Δt -10	0.1	0.3	0.5	0.5	0.6
Δt +10	0.7	1.0	1.9	2.6	3.2
Δt +5	0.6	0.9	1.7	2.4	2.8
Throw to 0.25 m/s Isothermal (M)	1.0	0.8	1.5	2.0	2.5
Δt -5	0.4	0.6	1.2	1.6	2.0
Δt -10	0.3	0.5	0.9	1.2	1.5
Noise level (top or side entry) (NC)	15	20	20	25	35

2 Way Blow

Volume flow rate (M ³ /S)	0.031	0.047	0.062	0.078	0.094
Pressure drop SP (top or side entry) (Pa)	3	8	15	24	36
Δt +10	N/A	0.8	1.0	1.4	1.6
Δt +5	N/A	0.7	0.8	1.2	1.4
Throw to 0.50 m/s Isothermal (M)	N/A	0.6	0.7	1.0	1.2
Δt -5	N/A	0.5	0.6	0.8	1.0
Δt -10	N/A	0.4	0.5	0.6	0.8
Δt +10	N/A	1.8	3.2	3.7	5.0
Δt +5	N/A	1.6	2.8	3.2	4.5
Throw to 0.25 m/s Isothermal (M)	N/A	1.4	2.4	2.8	3.8
Δt -5	N/A	1.1	1.9	2.2	3.0
Δt -10	N/A	0.8	1.4	1.6	2.3
Noise level (top or side entry) (NC)	15	20	25	35	40

Inlet Size
200 Dia



Inlet Size 200 Dia continued

4 Way Blow

Volume flow rate (M ³ /S)	0.031	0.047	0.062	0.078	0.094
Pressure drop (SP) (top or side entry) (Pa)	3	8	15	24	36
Δt +10	N/A	0.5	0.6	1.0	1.4
Δt +5	N/A	0.4	0.5	0.9	1.2
Throw to 0.50 m/s Isothermal (M)	N/A	0.3	0.4	0.6	1.0
Δt -5	N/A	0.2	0.3	0.6	0.8
Δt -10	N/A	0.1	0.2	0.5	0.6
Δt +10	N/A	0.9	1.8	2.6	3.5
Δt +5	N/A	0.8	1.5	2.3	3.0
Throw to 0.25 m/s Isothermal (M)	N/A	0.7	1.0	2.0	2.6
Δt -5	N/A	0.6	0.9	1.6	2.0
Δt -10	N/A	0.5	0.8	1.2	1.5
Noise level (top or side entry) (NC)	15	20	25	35	40

Inlet Size 250 Dia

1 Way Blow

Volume flow rate (M ³ /S)	0.049	0.073	0.098	0.122	0.147
Pressure drop (SP) (top or side entry) (Pa)	5	10	16	25	36
Δt +10	1.6	2.1	3.3	5.0	6.6
Δt +5	1.4	1.9	2.9	4.4	5.8
Throw to 0.50 m/s Isothermal (M)	1.2	1.6	2.5	3.8	5.0
Δt -5	1.0	1.2	2.0	3.0	4.2
Δt -10	0.7	0.9	1.5	2.3	3.0
Δt +10	3.5	5.2	7.0	9.0	12.0
Δt +5	3.0	4.6	6.0	8.0	10.5
Throw to 0.25 m/s Isothermal (M)	2.6	4.0	5.2	6.8	9.0
Δt -5	2.0	3.2	4.1	5.4	7.2
Δt -10	1.5	2.4	3.1	4.0	5.4
Noise level (top or side entry) (NC)	15	20	25	30	45

2 Way Blow

Volume flow rate (M ³ /S)	0.049	0.073	0.098	0.122	0.147
Pressure drop (SP) (top or side entry) (Pa)	5	10	16	25	36
Δt +10	0.7	1.0	1.7	2.5	3.3
Δt +5	0.6	1.3	1.5	2.2	2.9
Throw to 0.50 m/s Isothermal (M)	0.5	0.8	1.3	1.9	2.5
Δt -5	0.4	0.6	1.0	1.4	2.0
Δt -10	0.3	0.5	0.8	1.1	1.5
Δt +10	2.0	3.5	5.3	6.6	8.5
Δt +5	1.8	3.0	4.6	5.8	7.5
Throw to 0.25 m/s Isothermal (M)	1.5	2.6	4.0	5.0	6.4
Δt -5	1.2	2.0	3.2	4.2	5.1
Δt -10	0.9	1.5	2.4	3.0	3.8
Noise level (top or side entry) (NC)	15	25	30	35	45

4 Way Blow

Volume flow rate (M ³ /S)	0.049	0.073	0.098	0.122	0.147
Pressure drop (SP) (top or side entry) (Pa)	5	10	16	25	36
Δt +10	0.6	0.9	1.3	2.0	2.8
Δt +5	0.5	0.8	1.1	1.8	2.4
Throw to 0.50 m/s Isothermal (M)	0.3	0.5	1.0	1.5	2.0
Δt -5	0.2	0.4	0.8	1.2	1.6
Δt -10	0.1	0.3	0.6	1.0	1.2
Δt +10	1.6	2.5	3.6	4.0	4.6
Δt +5	1.4	2.2	3.2	3.5	4.0
Throw to 0.25 m/s Isothermal (M)	1.0	1.9	2.7	3.0	3.5
Δt -5	0.9	1.5	2.1	2.4	2.8
Δt -10	0.7	1.1	1.6	1.8	2.1
Noise level (top or side entry) (NC)	15	20	25	30	45



Supply Units Inlet Size 315 Dia

1 Way Blow

Volume flow rate (M ³ /S)	0.078	0.117	0.156	0.195	0.234
Pressure drop (SP) (top or side entry) (Pa)	5	10	16	25	36
Δt +10	2.0	4.7	7.3	9.0	10.5
Δt +5	1.7	4.2	6.4	7.8	9.3
Throw to 0.50 m/s Isothermal (M)	1.5	3.6	5.5	6.7	8.0
Δt -5	1.2	2.8	4.4	5.5	6.4
Δt -10	0.9	2.1	3.3	4.0	4.8
Δt +10	5.0	7.8	12.0	14.5	17.0
Δt +5	4.4	6.7	10.5	13.0	15.5
Throw to 0.25 m/s Isothermal (M)	3.8	6.0	9.0	11.2	13.5
Δt -5	3.0	4.8	7.1	8.9	10.8
Δt -10	2.3	3.5	5.4	6.7	8.0
Noise level (top or side entry) (NC)	20	25	30	35	45

2 Way Blow

Volume flow rate (M ³ /S)	0.078	0.117	0.156	0.195	0.234
Pressure drop (SP) (top or side entry) (Pa)	5	10	16	25	36
Δt +10	1.6	2.4	3.7	6.0	8.0
Δt +5	1.4	2.2	3.2	5.2	7.0
Throw to 0.50 m/s Isothermal (M)	1.0	1.8	2.8	4.5	6.0
Δt -5	1.0	1.4	2.2	3.6	4.8
Δt -10	0.7	1.0	1.7	2.7	3.6
Δt +10	3.8	5.3	8.0	9.0	10.0
Δt +5	3.1	4.6	7.0	8.0	9.0
Throw to 0.25 m/s Isothermal (M)	2.8	4.0	6.0	7.0	8.0
Δt -5	2.3	3.2	4.7	5.5	6.4
Δt -10	1.7	2.4	3.5	4.0	4.8
Noise level (top or side entry) (NC)	20	25	30	35	45

4 Way Blow

Volume flow rate (M ³ /S)	0.078	0.117	0.156	0.195	0.234
Pressure drop (SP) (top or side entry) (Pa)	5	10	16	25	36
Δt +10	0.7	1.3	2.0	2.9	4.0
Δt +5	0.6	1.1	1.8	2.5	3.5
Throw to 0.50 m/s Isothermal (M)	0.5	1.0	1.5	2.2	3.0
Δt -5	0.4	0.8	1.2	1.7	2.4
Δt -10	0.3	0.6	1.0	1.3	1.8
Δt +10	2.0	3.0	4.0	5.0	6.0
Δt +5	1.8	2.6	3.5	4.4	5.2
Throw to 0.25 m/s Isothermal (M)	1.5	2.2	3.0	3.8	4.5
Δt -5	1.2	1.7	2.4	3.0	3.6
Δt -10	0.9	1.3	1.8	2.2	2.7
Noise level (top or side entry) (NC)	20	25	30	35	45

Extract Units (522/527sq with TCB)

	Volume flow rate (M ³ /S)	0.002	0.03	0.04	0.05	0.06
160 Dia Outlet	Pressure drop (top entry) -SP (Pa)	1.5	2.7	4.7	8.0	12.5
	Noise level (NC)	15	15	20	20	20
	Volume flow rate (M ³ /S)	0.031	0.047	0.062	0.078	0.094
200 Dia Outlet	Pressure drop (top entry) -SP (Pa)	1.5	2.7	4.7	8.0	12.5
	Noise level (NC)	15	15	20	20	20
	Volume flow rate (M ³ /S)	0.049	0.073	0.098	0.122	0.147
250 Dia Outlet	Pressure drop (top entry) -SP (Pa)	1.5	2.7	4.7	8.0	12.5
	Noise level (NC)	15	15	20	20	20
	Volume flow rate (M ³ /S)	0.078	0.117	0.156	0.195	0.234
315 Dia Outlet	Pressure drop (top entry) -SP (Pa)	1.5	2.7	4.7	8.0	12.5
	Noise level (NC)	15	15	20	20	20

Extract Units (no plenum)

	Volume flow rate (M ³ /S)	0.05	0.07	0.10	0.12	0.15
227 x 227	Pressure drop (top entry) -SP (Pa)	2	4	9	13	23
	Noise level (NC)	25	30	35	35	40
	Volume flow rate (M ³ /S)	0.10	0.16	0.21	0.26	0.32
327 x 327	Pressure drop (top entry) -SP (Pa)	3	4	10	15	24
	Noise level (NC)	25	30	35	35	40
	Volume flow rate (M ³ /S)	0.18	0.27	0.36	0.45	0.54
422 x 422 427 x 427	Pressure drop (top entry) -SP (Pa)	3	5	11	17	25
	Noise level (NC)	25	30	35	35	40
	Volume flow rate (M ³ /S)	0.27	0.41	0.55	0.68	0.82
522 x 522 527 x 527	Pressure drop (top entry) -SP (Pa)	3	7	13	20	27
	Noise level (NC)	25	30	30	40	45



SERIES PG

Ordering Specification (Diffuser)

SERIES: PG, PG-T, PG-B, PG-R, PG-RT, PGR-B	PG	MD	160	522	TD8	PIP 19	DR	AS REQUIRED	4
AIR PATTERN : Supply - 1, 2, 2E, 3 or 4 Way Supply - MD (Adjustable Direction) Return - R									
SPIGOT SIZE (Supply Only)									
LIST SIZE (mm)									
REGULAR DROP DEPTH mm (PGT only - TD + DEPTH)									
PIP HEIGHTS (mm) Applies to PGB ref - PIP + Height									
DAMPER OPTION: Rotary.....DR (Supply) Opposed Blade...DO (Extract) (for matt black finish add ref. BB ie: DO/BB)									
FINISH (please specify)									
NUMBER REQUIRED									

Ordering Specification (Plenum Box)

SERIES: SEB/PG, PGT, PGB TCB/PGR, PGRT, PGRB SEB/PGR, PGRT, PGRB	SEB/PG	AT1	522	BH500	BB	DQ160Dia	TSO	DQ300Dia	15
THERMAL/ACOUSTIC INSULATION (SEB only) 12 mm Pyro (standard)..... AT1 25 mm Pyro AT2 12 mm Armaflex AT3									
LIST SIZE OF DIFFUSER CONNECTED TO (mm)									
BOX HEIGHT (where different from standard)									
MATT BLACK INTERNALS Option:.....BB									
SPIGOT DAMPER OPTIONS No Damper.....SS + size Rotary (TCB only)DR + size Quadrant (SEB only)DQ + size									
TWIN SPIGOT OPTION (SEB): Adjacent.....TSA Opposite.....TSO									
TWIN SPIGOT DAMPER OPTIONS No Damper.....SS + size Rotary (TCB only)DR + size Quadrant (SEB only)DQ + size									
NUMBER REQUIRED									

FIXING

Standard fixing is via drop rods (by others) to support brackets at rear.

FINISH

Standard finish: PPC White Ral 9010 20% gloss.
Special finish: PPC to Stock BS or RAL colour.
Note: Internals matt black

Contact

GILBERTS

Head Office and Works
GILBERTS (BLACKPOOL) LTD
Gilair Works, Clifton Road,
Blackpool.
Lancashire FY4 4QT.
Telephone: (01253) 766911
Fax: (01253) 767941
e-mail: sales@gilbertsblackpool.com
Web: www.gilbertsblackpool.com

