

SMOKEGARD

Door, Wall and Partition Mounting Smoke & Fire Dampers

SFB (57.9) X

UDC 697.9

Dampers 2 | JAN 2005



Features

- Slimline construction.
- Smoke or fire operated .
- Stainless steel interlocking blades and side seals for maximum smoke retardation.
- Galvanised steel frame.
- Easy key reset.
- 1 hour door & 2 hour wall mounting fire ratings.

□



GILBERTS



Introduction

Gilberts Smokegard Dampers provide a revolutionary “Engineered” answer to the problem of smoke and fire protection in fire doors, walls and partitions. A unique patented blade linkage mechanism has produced a Damper narrow enough to fit within the confines of a 1/2 hour (44mm) door, 1 hour (54mm) door or any wall/partition and allow the passage of ventilation air in normal conditions but prevent the spread of smoke and flames in fire conditions.

Five modes of operation are available (3x failsafe closed and 2x failsafe open) ranging from basic Mode A, which is Fire only operated, to the Mode C which is Fire and Smoke operated and complete with in built status indicators. All units comprise of a Galvanised Steel Frame with Stainless Steel Inter-Locking Blades and Side Seals, combining rugged construction with maximum Fire and Smoke retardation capabilities whilst the inter-connecting Rack Blade operation feature is incorporated to ensure faultless precision Damper Operation.

Fire tested to BRITISH STANDARD 476 PART 20 1987 the units are 2 hour rated, having been tested for 4 hours in a wall and 1 hour in a door.

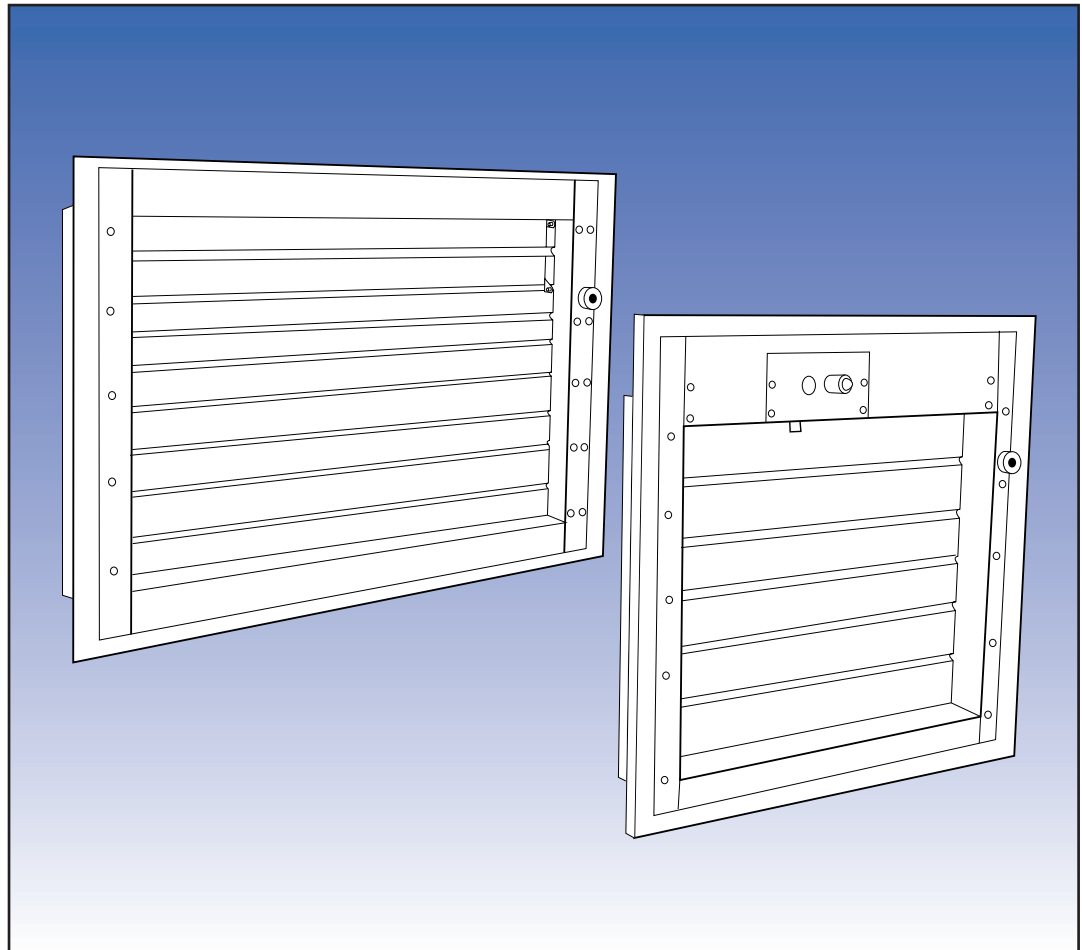

- Five control modes available
- Available in Fire or Smoke & Fire modes
- Interlocking Stainless Steel blades and frame side seals provide a tight seal against smoke and flames
- Fusible link elements close the Damper instantly at between 70/80°C
- Galvanised Steel frame construction to resist corrosion
- Simple key reset mechanism in the event of activation
- Indication lights available to provide a visual display of Damper status
- Integral test facility provided on Mode C



Mode A Fire Operated

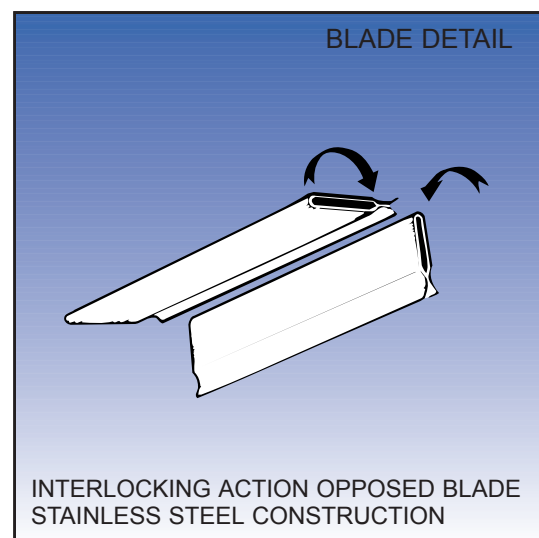
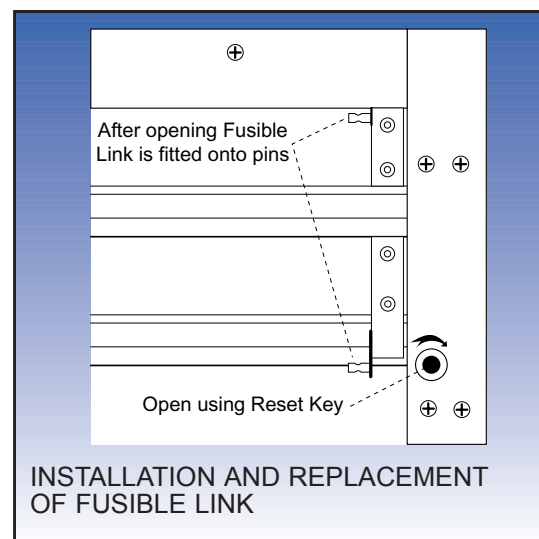
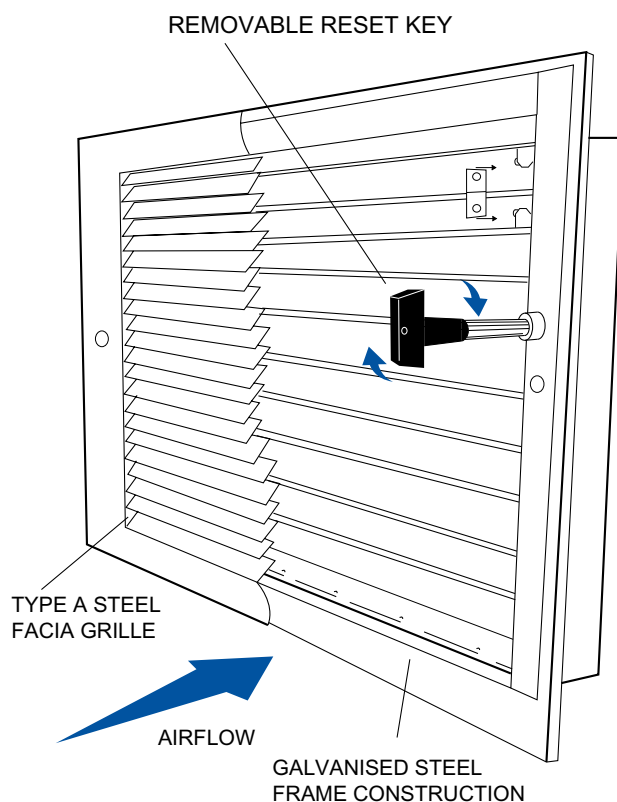

Mode A

Gilberts Smokegard Mode A has been designed to allow the passage of ventilation air in normal conditions and prevent the spread of FLAMES in fire conditions. It is available in a wide range of sizes to cater for most air flow requirements and is supplied with a door sleeve suitable for a 45mm or 54mm door or a wall sleeve suitable for a wall or partition of specified thickness. The damper can be suitably masked on both sides either with steel type A grilles or aluminium non-vision type B grilles.

OPERATION: The unit is activated by an integral fusible link assembly. This assembly is under constant spring tension to close the interlocking blades and is only released, under fire conditions, by the melting of the holding solder at 72°C which allows the blades to close INSTANTLY.

RESET PROCEDURE: Reset or initial setting is accomplished by the insertion of a special key through a hole in the inside frame (removal of fascia grille is required for access). The key is turned in a clockwise direction until the blades are fully open and then, whilst holding the blades open with the key, the fusible link is fitted over its locating pins on the top pair of blades.

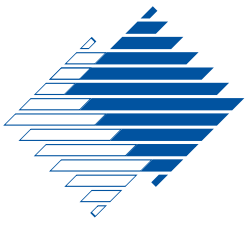

Mode A Dimensions

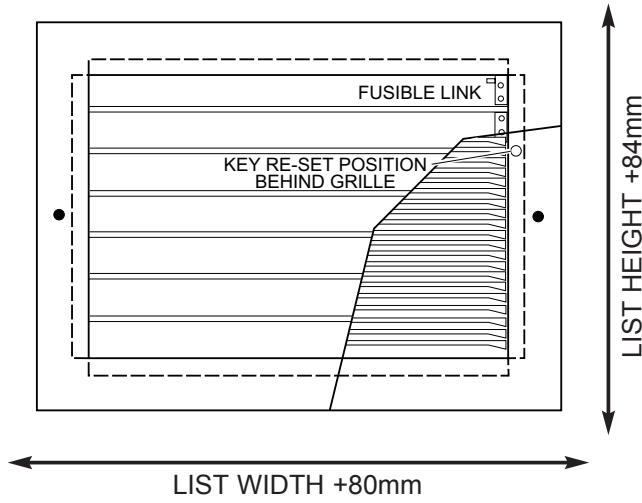

TYPE A GRILLE

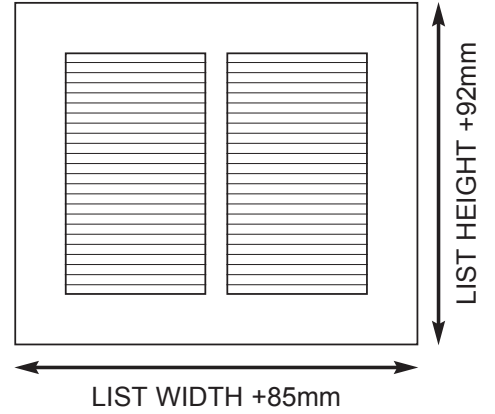

SECTION THROUGH WALL/DOOR

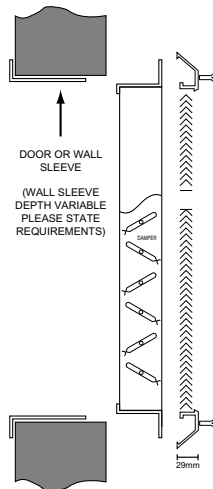

LIST SIZES AVAILABLE

- WIDTH 200mm in 50mm increments to 400mm
- HEIGHT 100mm in 100mm increments to 400mm
- Reverse sizes available only upon request

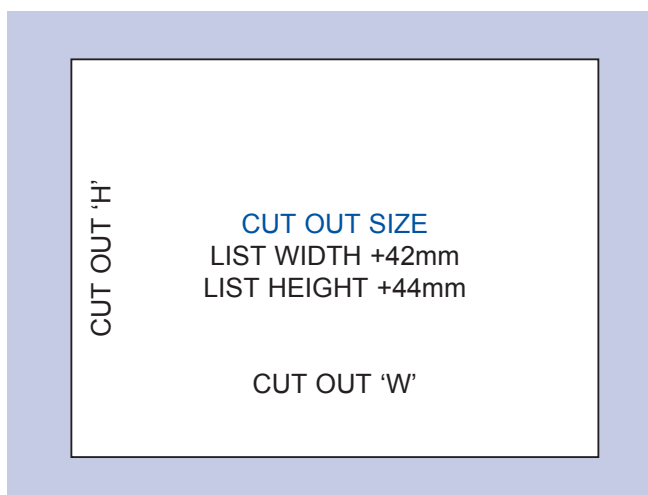

TYPE B GRILLE

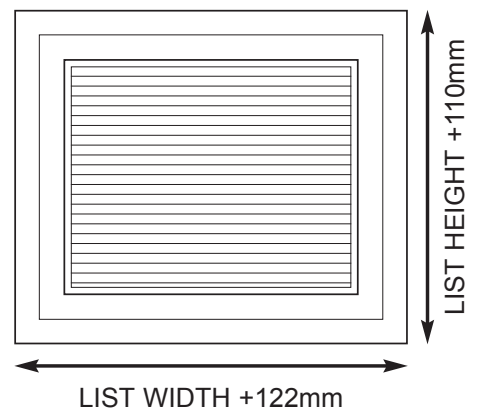

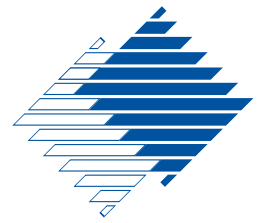

Mode B & C Smoke & Fire Operated

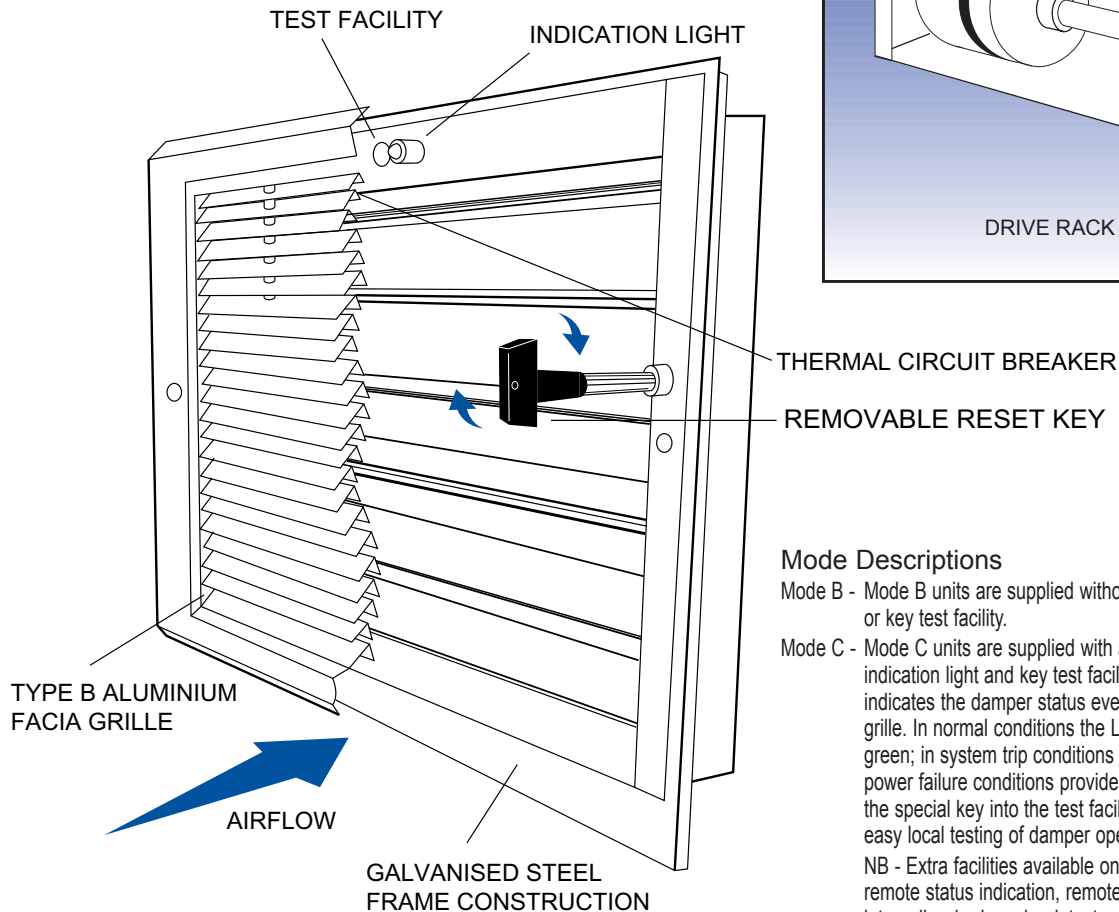

Mode Descriptions

Mode B - Mode B units are supplied without status indication light or key test facility.

Mode C - Mode C units are supplied with an LED status indication light and key test facility. The LED visibly indicates the damper status even when behind a fascia grille. In normal conditions the LED indicates a steady green; in system trip conditions a steady red and in power failure conditions provides no display. Inserting the special key into the test facility socket provides for easy local testing of damper operation.

NB - Extra facilities available on Modes B & C include remote status indication, remote operation and integrally wired smoke detector operation. Please refer to wiring diagram for details.

Mode B & C

Gilberts Smokegard Modes B & C have been designed to allow the passage of ventilation air in normal conditions and prevent the spread of SMOKE AND FLAMES in fire conditions. They are available in a wide range of sizes to cater for most air flow requirements and are supplied complete with a door sleeve and electrical door wiring loop for a 45mm or 54mm door or a wall sleeve only, for a wall/partition. The damper can be suitably masked on both sides either with steel type A grilles or aluminium non-vision type B grilles.

OPERATION: The units are operated by a 24V DC electrical supply. This 24V DC supply provides power for the damper's integral electro magnet which in normal conditions hold the damper blades open. In fire conditions, however, when the fire protection system detects the presence of fire or smoke, it will interrupt the power supply to the damper causing the electro magnet to release the blades. The damper will then close INSTANTLY under spring tension.

If fire were to reach the damper without such detection, the unit would close regardless of external sources at 72°C by the action of its integral Electro thermal fuse.

RESET PROCEDURE: Reset or initial setting, which can be accomplished with the fascia grilles in place, is achieved by the insertion of a special key through a hole in the grille and damper frame. With the main 24V DC supply live the key is turned in a clockwise direction until the blades are fully open. The electro magnet will then lock and hold the blades and the key can be removed.

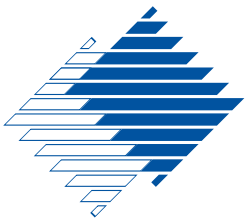

Mode B & C Dimensions

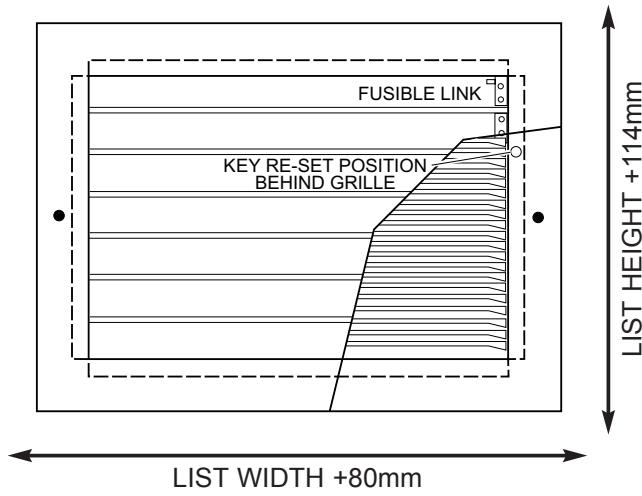

TYPE A GRILLE

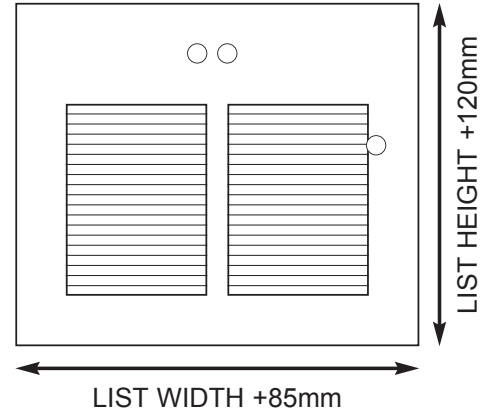

SECTION THROUGH WALL/DOOR

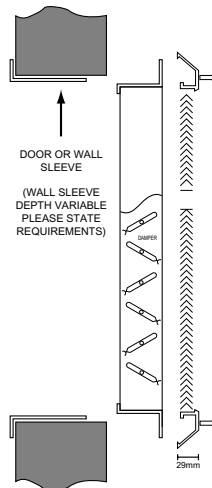

LIST SIZES AVAILABLE

WIDTH 200mm in 50mm increments to 400mm

HEIGHT 100mm in 100mm increments to 400mm

Reverse sizes available upon only request

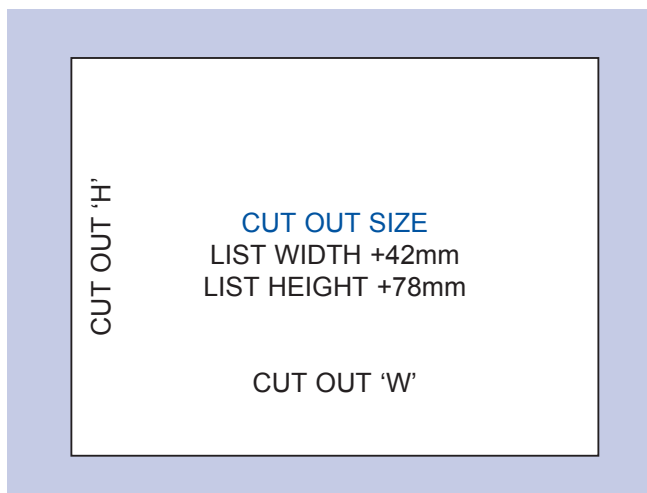

TYPE B GRILLE

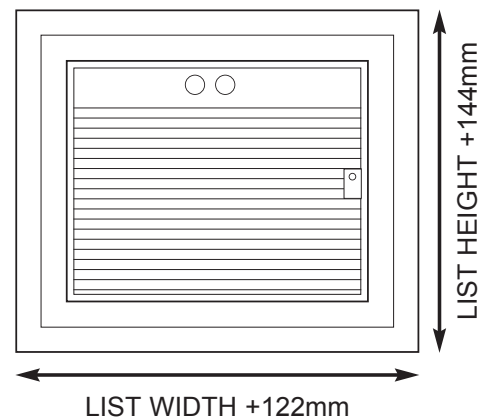

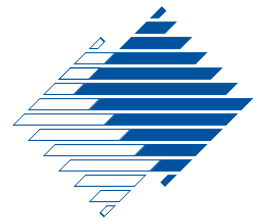

Ancillary Items

Gilberts range of ancillary items have been designed for use in conjunction with Smokegard Damper Modes B & C. Purpose made for straight forward connection to the units they offer a number of useful services.

Remote Indicators

Gilberts remote indicator panels can be linked to Damper Modes B & C and provide remote indication of the status of one damper. Powered by the yellow and blue switch wires from the Smokegard and the -VE DC supply the panel LED indicates

- Green - Damper Open
- Red - Damper Closed
- No Light - No Supply Voltage - Damper Closed

Ref:- SRI 1

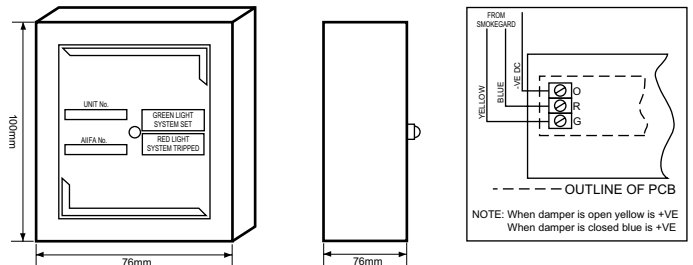

Master Monitor

A more advanced form of remote indication is available with a master monitor. This unit provides remote indication for the status of up to 12 individual dampers. Details as for Remote Indicator.

Ref:- SMM1-12*

* dependant on number of dampers on the system

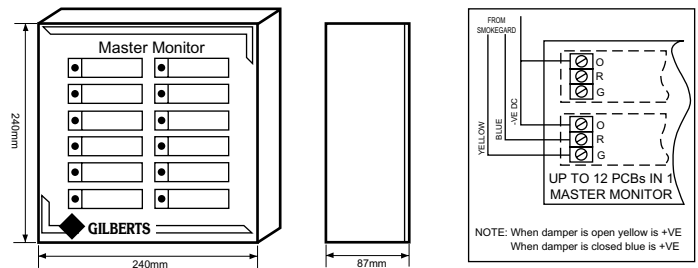

Standard Power Supply

Standard power supplies are available in two sizes to suit up to 6 or 12 dampers. They provide conversion from 240v AC input to a smooth and stabilised 24v DC output.

- Ref:-
- G6 = 6 UNIT
 - G12 = 12 UNIT
 - G6R = 6 UNIT + INTERFACE RELAY
 - G12R = 12 UNIT + INTERFACE RELAY

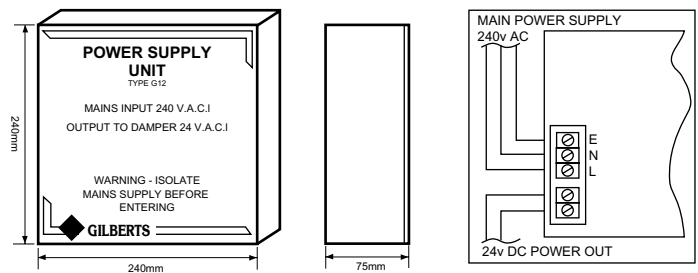

Uninterruptible Power Supply

Uninterruptible power supplies operating on a 240v AC input provide a smooth 24v DC output to power up to 6 or 12 dampers. Unlike standard power supplies however, in the event of a power failure, there will be an automatic changeover to in-built batteries without tripping the dampers providing continued power for a period of up to 1 hour.

- Ref:-
- UPS6 = 6 UNIT
 - UPS12 = 12 UNIT
 - UPS6R = 6 UNIT + INTERFACE RELAY
 - UPS12R = 12 UNIT + INTERFACE RELAY

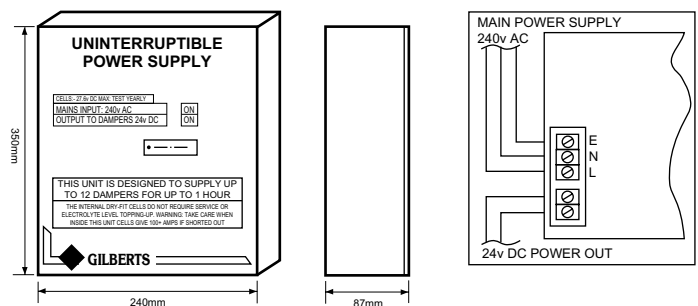

Smoke Detectors

Smoke Detectors are available for ceiling mounting and can link directly into Modes B or C or the output relay of the Power Supply units. Detectors are 24v DC Ionisation type.

Ref: 4 wire - SD2

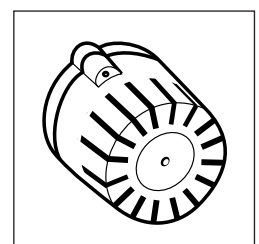



Wiring Details Modes B & C

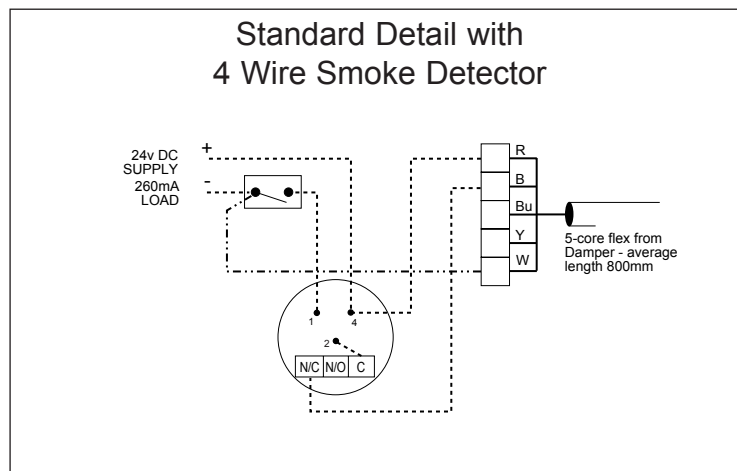
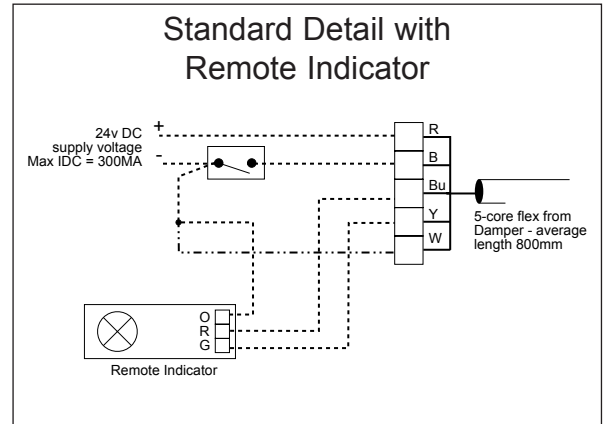
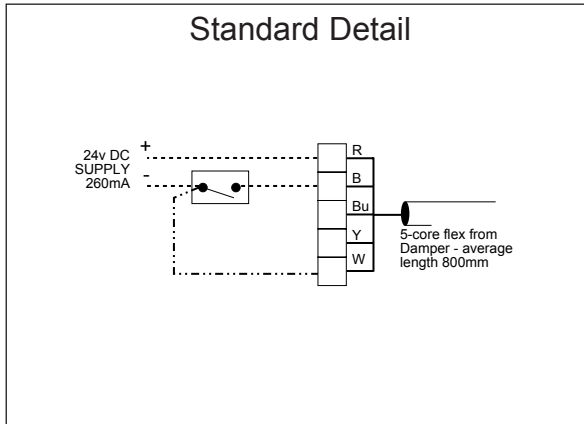

----- External Wiring By Others

- - - - - For Permanent Local Indication

IMPORTANT: SMOKEGARD UNITS REQUIRE A SMOOTH AND STABILISED 24V DC SUPPLY +/- 2 VOLTS WITH A MAXIMUM 3 VOLT AC RIPPLE

The Smokegard B & C Dampers are supplied pre-wired with a 5-core pvc insulated flex for connection as follows:

- | | |
|--------|--|
| RED | 24v+ DC supply input |
| BLACK | 24v- DC supply input |
| BLUE | 24v DC +output with damper tripped |
| YELLOW | 24v DC +output with damper set |
| WHITE | - VE input if local led permanently required when supply voltage switches to operate dampers |

The yellow and blue wires are only utilised if remote indication of damper status is required. These 2 wires should be insulated if not required.

MODE C only

The Mode C Smokegard has an integral LED to indicate the blade position of the damper (open/closed). It fits into the right of the 2 circular apertures located on the top frame of the damper.

A key is also provided for local control or test. To test the damper, insert the key into the left of the 2 circular apertures.

NOTE: Should access to the pcb be required for any reason ISOLATE the DC supply prior to undertaking any work.



Installation Procedures

Door Mounted or Light Structure Partitions

1. Aperture to be cut into door to match the DAMPER size (Aperture dimensions detailed on page 5).
2. The backing sleeve should now be entered into the opening to allow marking of fixing bolt hole locations.
3. Remove the backing sleeve and drill 5mm diameter bolt holes where marked.

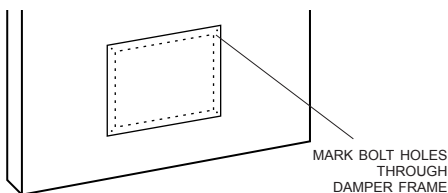

4. MODE A Type unit can be reinstalled in the aperture and, with the mating back sleeve inserted on the opposite side, secured using the set of screws and nuts provided.

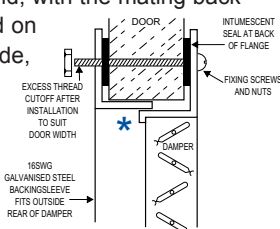

MODE B & C Type units will now require electrical connection before completing installation. After the aperture has been cut into the door a 6mm diameter wiring hole must be drilled from the door edge, through the centre of the door, in line with the top of the damper from the door to the jamb. Upon reaching the edge of the door therefore, a routing will then need to be made to allow the cable to enter the loop, as illustrated, for terminal block connection. (The damper cable is colour coded. Please refer to Wiring Diagram for correct connection). The damper can then be installed and, with the mating back sleeve inserted on the opposite side, secured using the set screws and nuts provided.

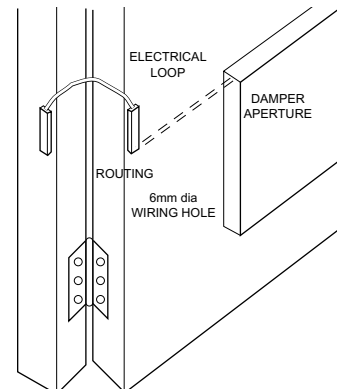

5. The Fascia Grilles can now be fitted over the damper and fixed with self tapping screws provided.

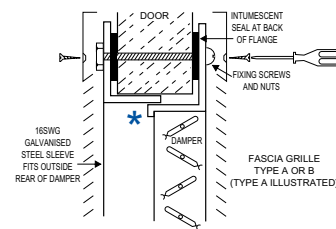

Wall Mounting

1. Aperture to be cut into wall to match the damper size (aperture dimensions detailed on page 5).

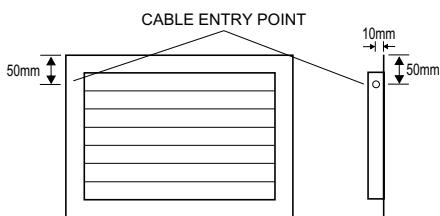

2. The rear sleeve should now be fixed into the wall and secured with suitable screws (and plugs if necessary) through the flange.
3. Mode A type Dampers, which do not require an electrical connection, can now be fitted from the front and secured with suitable screws (and plugs if necessary) through the flange.
4. Mode B and C type Dampers, require electrical connection before installation

is complete.

The dampers are supplied with approximately one metre of flex to which a secure insulated connection is recommended.

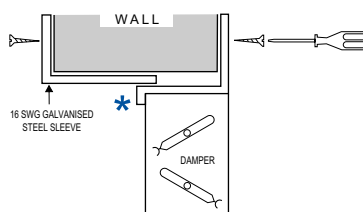

The damper cable is colour coded. Please refer to Wiring Diagram for correct connection. Once these connections have been completed the damper can be fitted into the aperture and

secured with suitable screws (and plugs if necessary) through the flange.

5. The front and rear fascia grilles for all modes can then be fitted over the damper and fixed with the self tapping screws provided through the holes in the flanges.

*It is recommended that an Intumescent Sealant is inserted at this point between the overlapping sleeves.

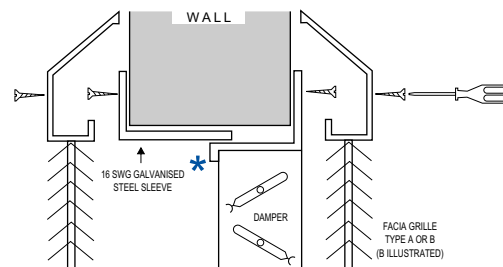

Maintenance of Components

All units are tested before leaving the factory, but should be test operated prior to commissioning and regularly thereafter to ensure correct operation. Test frequency will depend upon Damper environment however a maximum interval of 6 months is recommended. In addition an Annual Visual Inspection is also advisable to permit cleaning and removal of any airborne contaminants which may affect the Damper operation. (NB for safety the Damper Blades should be closed before personally approaching them for inspection/cleaning).

The Dampers contain no other user serviceable parts, any faults are best referred to the manufacturer.

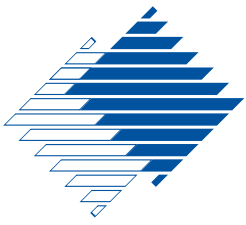

Nomogram

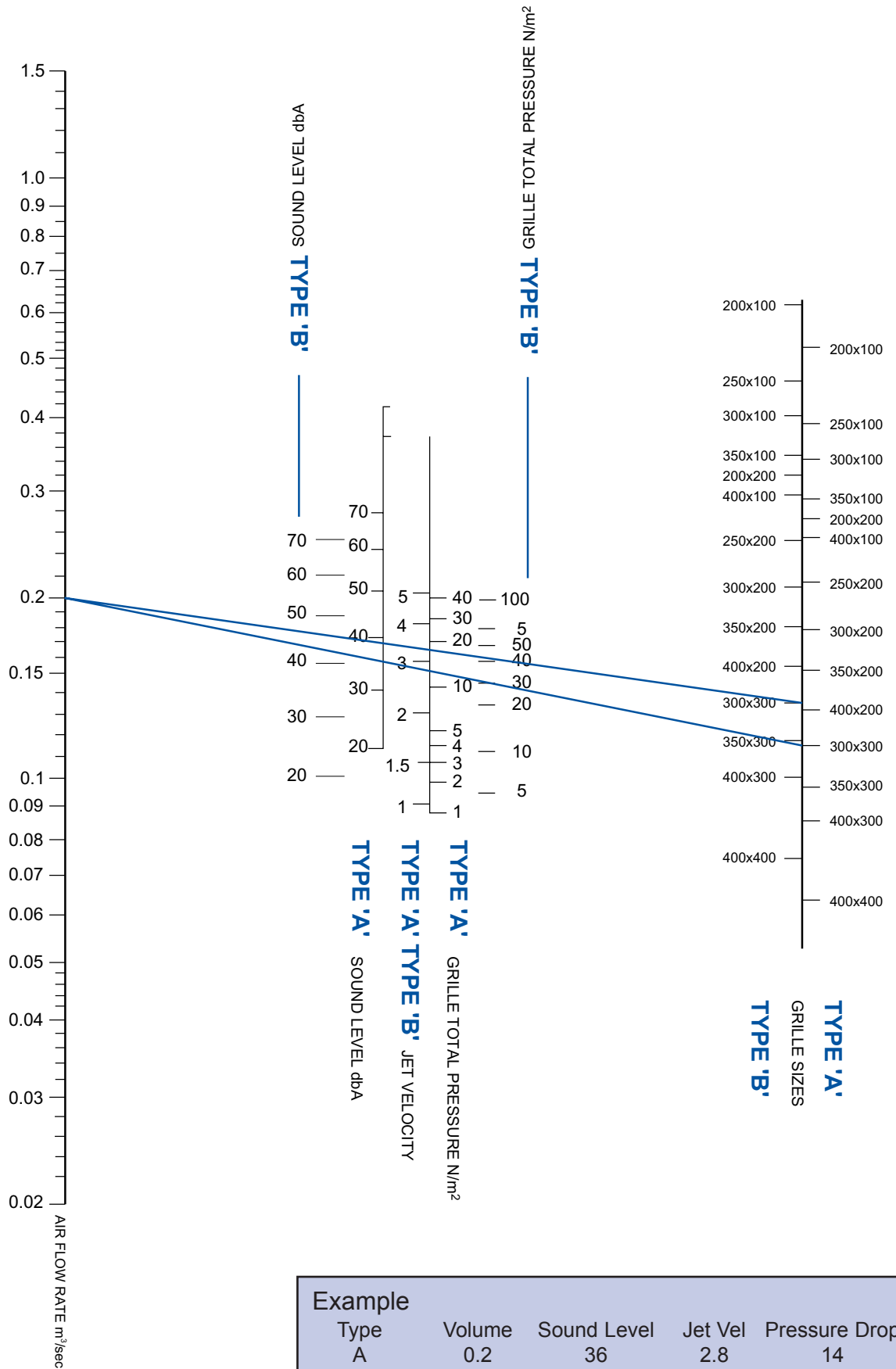

Example				
Type	Volume	Sound Level	Jet Vel	Pressure Drop
A	0.2	36	2.8	14
B	0.2	45	3.3	46

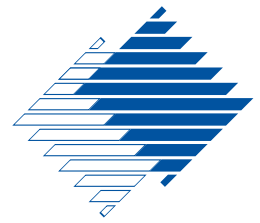

Test Data Fire Tests

Introduction

All fire tests were conducted by the WARRINGTON RESEARCH CENTRE to BRITISH STANDARD 476 PART 20 1987.

This test describes the performance of structural elements under fire conditions, and considering there is no standard test for this type of fire damper it was decided to mount both a fusible link operated, and also an electro-magnet operated fire damper in a standard 1 hour timber fire door.

Test Description

Tests were conducted in order to test both the stability and integrity of the units, and it was felt that mounting them in a fire door would demonstrate the most severe combined situation for which the units would likely be installed. Not only were the fire dampers scrutinised during the test, but also the combined situation thus demonstrating the total integrity of the installation.

Units tested were of a size 400 Wide x 400mm High which is the largest manufactured size for this type of unit. They were installed within 54mm thick fire doors with a suitable backing flange, and secured with mild steel bolts from one face flange to the other through the door itself. The combined assembly was placed vertically against one open side of a 1m³ furnace and then securely bolted to maintain an air seal between.

Test Results

The duration of the test was 1 hour, and only slight charring of the timber around the damper frame was apparent after this time. At the end of the test the integrity and stability of both the damper and door had been maintained.

STANDARD TIME-TEMPERATURE CURVE OF BS476 PART 20 1987

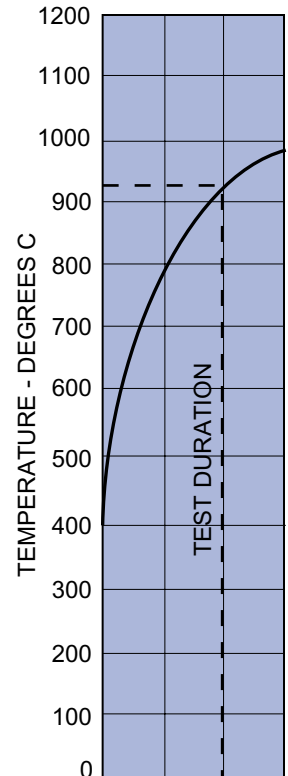

Air Flow Test Data

Introduction

The air flow test was conducted by the Building Research and Information Association.

AIR FLOW LEAKAGE CHARACTERISTIC OF A 300x200MM SMOKEGARD FIRE DAMPER IN THE CLOSED POSITION

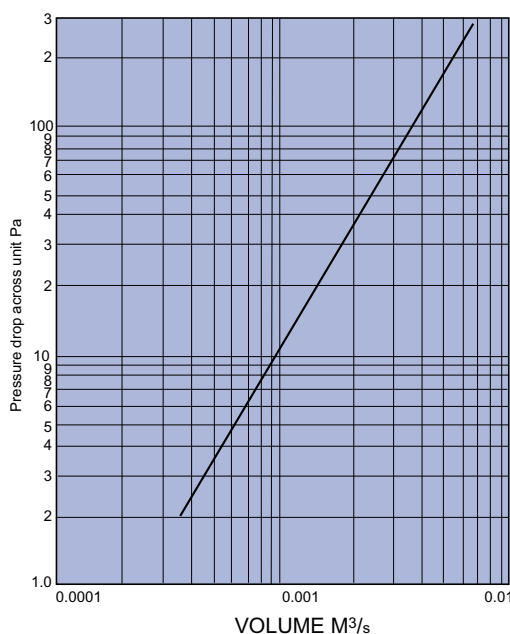

FLOW RATE - PRESSURE DROP CHARACTERISTIC FOR MULTI- BLADE FIRE DAMPER IN OPEN POSITION

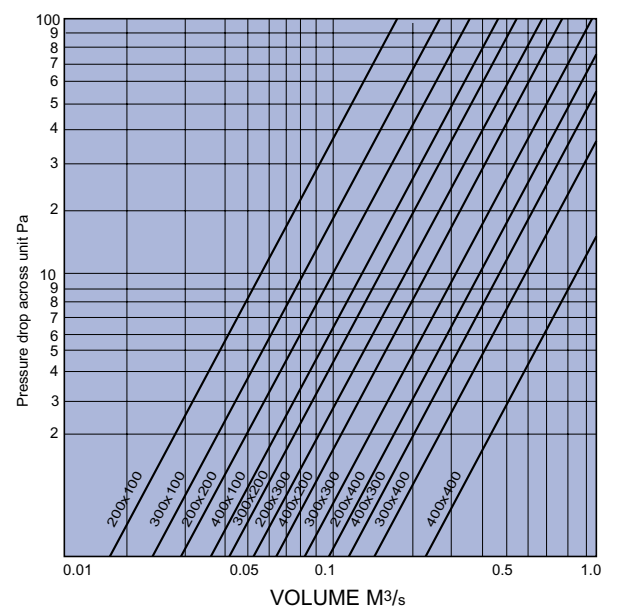

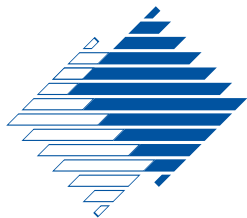

Ordering Specification

SERIES: SMOKEGARD	SG/A	W	300 x 200	125T	A	PPC SATIN SILVER (Standard Finish)	15
Failsafe Closed-							
Mode A.....	SG/A						
Mode B.....	SG/B						
Mode C.....	SG/C						
Failsafe Open-							
Mode RB.....	SG/RB						
Mode RC.....	SG/RC						
DOOR MOUNTED.....	D						
WALL MOUNTED.....	W						
SIZE (mm width x Height)							
WALL THICKNESS (mm)							
GRILLE TYPE A or B							
GRILLE FINISH (Please Specify)							
NUMBER REQUIRED							

STANDARD POWER SUPPLIES:	
6 Way.....	G6
6 Way c/w output relay.....	G6R
12 Way.....	G12
12 Way c/w/ output relay.....	G12R

REMOTE INDICATORS:	
Single unit.....	SR1

MASTER MONITOR:	
1 - 12 unit.....	SMM1 -12 plus per damper

UNINTERUPTABLE POWER SUPPLIES:	
6 Way.....	UPS6
6 Way c/w output relay.....	UPS6R
12 Way.....	UPS12
12 Way c/w/ output relay.....	UPS12R

SMOKE DETECTORS:	
24V DC wire ionisation.....	SD2

GRILLES:

TYPE A - All steel construction with horizontal louvres on 8.5mm centres with a 30° downward deflection.

TYPE B - Manufactured from extruded aluminium with vision proof core.

NOTES:

- MODE A type of unit provided with a fusible link set to operate at 72°C.
- MODE B & C type of unit provided with a Thermal Circuit Breaker set to operate at 72°C.
- MODES B & C type of units which are required for door mounting are provided with electrical jump loop to transfer wiring from door to jamb.
- All units provided with 16SWG mild steel galvanised sleeve to suit wall/door thickness.

FINISH:

Standard Finish is a PPC satin silver. Special Finishes are ppc to any stock BS/RAL colour.

Engineering Specification

Inner frame manufactured from 1.0mm galvanised mild steel to BS 1449 Part 1, CR4 Grade ZZ. Formed to channel shape with end flanges. The four parts of the inner frame are rivetted together with two stainless steel rivets 3mm diameter x 6mm long at each of the four corners. The outer frame is manufactured from 1.6mm galvanised mild steel formed into 4 sections and welded to form a rigid frame. The inner frame is secured through the flange onto the outer frame using No6 screws.

Blades of 0.457mm (26SWG) stainless steel to BS 1449 Part 2, 1975 302 S16, are formed into hollow section with a radiused leading edge and vee shaped trailing edge. The section is spot welded together after forming at the point of the vee, spotwelds at a pitch of 33mm. The blade ends are closed off by stainless steel end caps, material specification as per the blade and have stainless steel pivot pins rivetted to them, the pivot pins have suitable flats to engage the blade drive pinions. The end caps are secured to the blade by three 2.8mm diameter stainless steel rivets 6mm long at each end.

Holes in the inner side frame to accept the blade pivot pins are set at suitable spacings to allow blade leading edges to interlock in the vee of the next blade. Side seals of 0.152mm (38SWG) stainless steel as per blade specification, are formed and pierced to accept blade pivot pins, and are assembled between frame sides and blade ends. Top and bottom seals are manufactured in material as for side seals but are retained on top and bottom inner frames by nibs formed in frame inner surfaces.

The blades are actuated by a 3mm thick x 40mm steel rack located in the side frame, and acting on steel pinions attached to blade pivot pins. The rack and pinions are zinc plated and passivated, and are contained in the side frame by a cover plate for Modes B and C, the blades are held in the open position via the rack, which in turn is held by a conical ended stainless steel pin engaging in a female keyhole aperture in the rack. The action of the rack through the spring action is to disengage the pin, but this is prevented by an electro-magnet. When the electro-magnet is deenergised it allows the stainless steel pin to move forward, thus disengaging the rack which moves immediately to the closed position shutting the blade pack.

For Mode A units a 72°C Fusible link is mounted on pivot brackets on the two opposed action blades. On failure of said fuse link blades are allowed to move in opposed directions, synchronised and driven by the spring loaded rack and pinion arrangement.

Contact

GILBERTS

Head Office and Works
 GILBERTS (BLACKPOOL) LTD
 Gilair Works, Clifton Road,
 Blackpool.
 Lancashire FY4 4QT.
 Telephone: (01253) 766911
 Fax: (01253) 767941
 e-mail: sales@gilbertsblackpool.com
 Web: www.gilbertsblackpool.com

