

# SERIES GF

Heavy Duty  
Floor  
Grilles

PUBLICATION

GRILLES 15

MARCH 2009

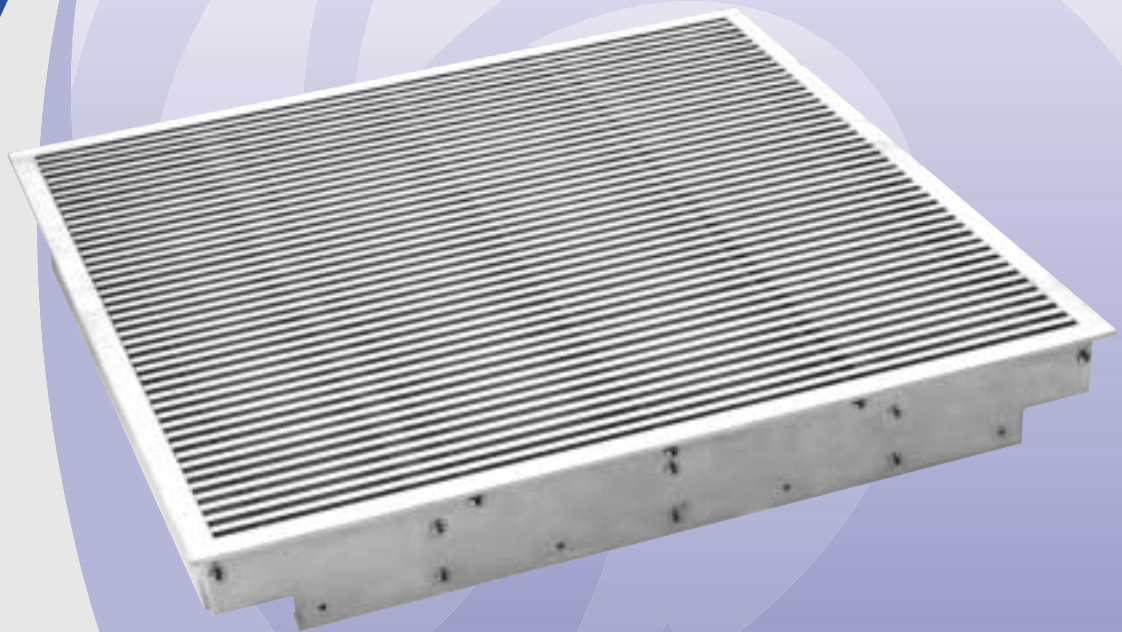

## Features

- Numerous Frame Formats to Suit Floor Types of all Manufacturers
- Robust Design.
- Strong and Rigid Assembly.
- Fully Tested to Current Floor Grille Specifications.
- All Extruded Aluminium Construction.



# GILBERTS

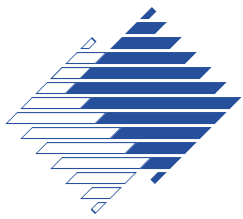

# SERIES GF

## Introduction

Gilberts GF Series is one of the most established and advanced ranges of floor grilles available in the industry today. Designed, principally, to replace 600mm sq tiles in raised access floor systems the units are suitable for both light to medium grade installations such as offices as well as heavy grade installations such as computer floors. The GF Series comprises of 6mm bars set straight on a close 13mm pitch, designed to prevent heel penetration and snagging, with blades fully supported at the sides and across the grille centre for maximum strength and rigidity. Catering for point

loads of up to 4.5kn, each unit can handle air volumes up to 300 l/sec and is available in a variety of frame formats to suit all the popular floor types.

Frame type 6 suits the majority of installations. Frame types 1, 2 & 3 are more specialised and designed for only limited floor types. Our technical department will be pleased to help identify the correct frame type for the application. Prior to despatch all floor grille corners are machined to match with the floor type and surface covering ensuring that floor level is always maintained.

**TYPE GFX/600:** Units comprise of 6mm bars set straight on a 13mm pitch in housing frame. Frame options 6, 3, 2 and 1 available to suit different floor types.

**Loading** All units are rated extra heavy duty in accordance with BS EN 13264:2001 PSA and IBM specifications.

**Restrictions** Full static and dynamic load restrictions detailed below.

All GF units are manufactured throughout from robust high grade aluminium extrusions to BS 1470-1474 and are available with two damper types dependant on frame option. Screwdriver operated Slot dampers, formed from opposed sliding plates, are the preferred option and are available on the standard frame type 6. Engineered to close tolerance for smooth, silent operation these discreet matt black dampers are position lockable and are completely enclosed within the grille body making transport and handling much easier, as well as reducing cost. Opposed blade dampers however are also available on all frame types with a choice of standard steel construction or higher cost aluminium. Aluminium opposed blade dampers can also be specified with a locking screw (see inside back cover) to prevent tampering. The standard finish is a natural mill finish (brushed on frames 1, 2 & 3). Enhanced finishes such as Shadowline (brushed grille face with internals matt black) and nylon colour coatings are available on request.

## Features

- Numerous Frame Formats to suit Floor Types of all Manufacturers.
- Robust Rigid Design.
- Strong and Rigid Assembly
- Fully Tested to current Floor Grille Specifications.
- All Extruded Aluminium Construction.

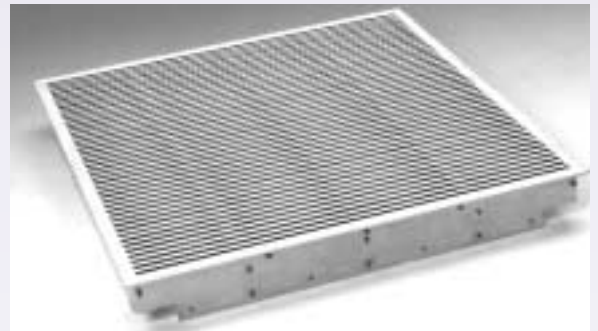

### Static Loadings

### Min Concentrated Load

#### Extra Heavy Duty

4.5 Kn over an area 25 x 25mm

NOTE: This grade is also required to sustain a total load of 11Kn applied equally on four points, each point 25 x 25mm on a 200 x 200mm square configuration at any point of the grille.

### Transient Load

### Rolling Load

#### Extra Heavy Duty

25 passes at 3Kn in each of 2 directions at right angles to each other  
25 passes at 4.5Kn in each of two directions at right angles to each other

NOTE: Both static and transient load tests were conducted on the GF Series.

The Extra Heavy Duty Units meet the structural and Electrical performance requirements of both the PSA MOB 08.801 (Extra Heavy Duty) and the relevant IBM Property Management Guide and BS EN 13264:2001.

## Installation

The Performance data tables that follow indicate the velocities, noise and pressure drop characteristics through the GFX/600.

## Selection Procedure

It is generally preferable to position grilles used for supply air purposes close to the generated heat sources (ie: in front of computers etc.) and away from the occupied areas of the rooms. This is basically because of the cooler air supplied at floor level and general comfort conditions for the occupants. A normal supply air jet velocity would be in the region of between 1.5 and 2 m/s, but this would be related to available pressures.

### Example:

**Total volume for computer room is 10 m<sup>3</sup>/s**

TYPE GFX/600/6

Max pressure drop of 3 Pa is required. Referring to the sizing chart for the GFX/600/6 this pressure limit indicates a unit (no damper) with a max vol. of 350 l/s. The sizing chart shows that at this volume the unit has a jet velocity 2.21m/s

and an NC level less than 15. Therefore:

$$\text{Total No of Grilles} = \frac{10\text{m}^3/\text{s}}{0.35\text{m}^3/\text{s}} = 28.57 \text{ (29 grilles required)}$$

TYPE GFX/600/1, 2 & 3

Max pressure drop of 3 Pa required. From the GFX/600/2 & 3 sizing chart this indicates a unit with approx Max Vol of 175 l/s. Jet velocity is approx 1.5m/s and NC level less than 15.

Therefore:

$$\text{Total No of Grilles} = \frac{10\text{m}^3/\text{s}}{0.175\text{m}^3/\text{s}} = 57.14 \text{ (58 grilles required)}$$

### References Used:

**Pressure** All pressures are in Pascals (N/m<sup>2</sup>)  
**Velocities** All jet velocities are in m/s  
**Volumes** All air volumes are in L/s

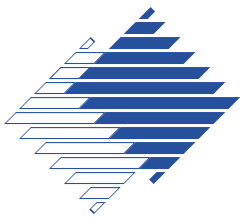

# SERIES GF

## Dimensional Data

### SERIES GFX (Extra Heavy Duty)

#### TYPE GFX/600/6

#### Frame Type 6

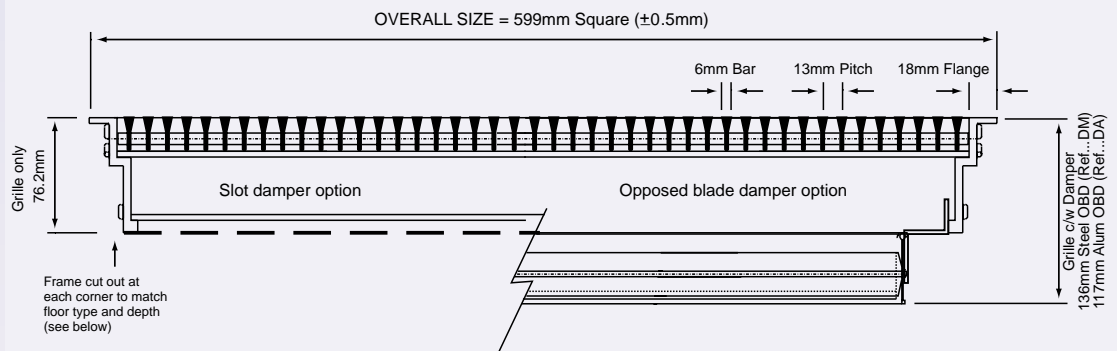

#### TYPICAL CORNER DETAIL

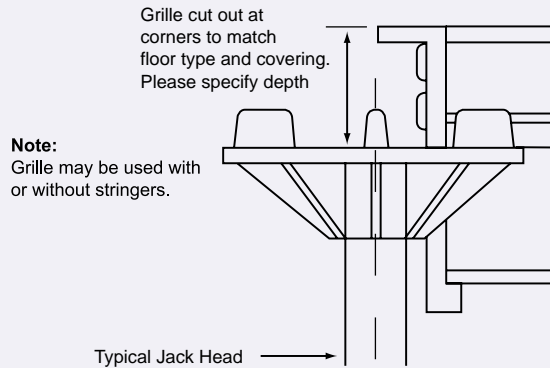

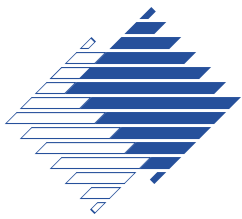

# SERIES GF

## Dimensional Data

### SERIES GFX (Extra Heavy Duty)

#### TYPE GFX/600/3

#### Frame Type 3

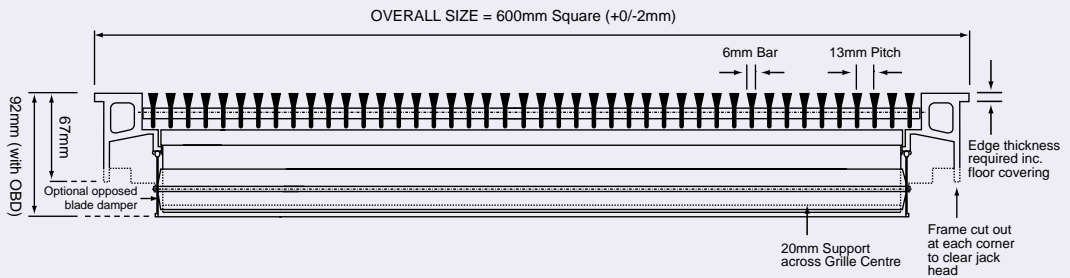

#### TYPE GFX/600/2

#### Frame Type 2

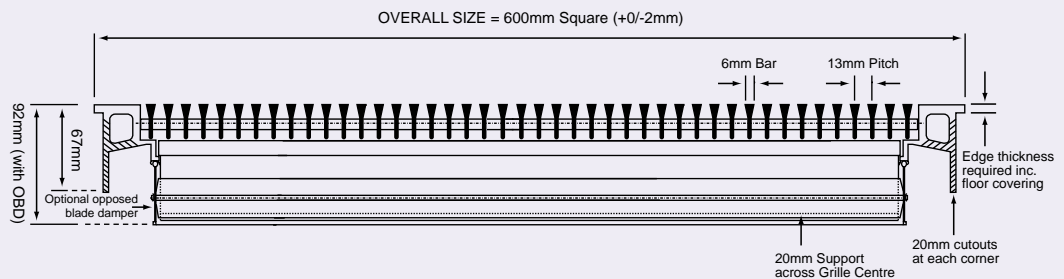

#### TYPE GFX/600/1

#### Frame Type 1

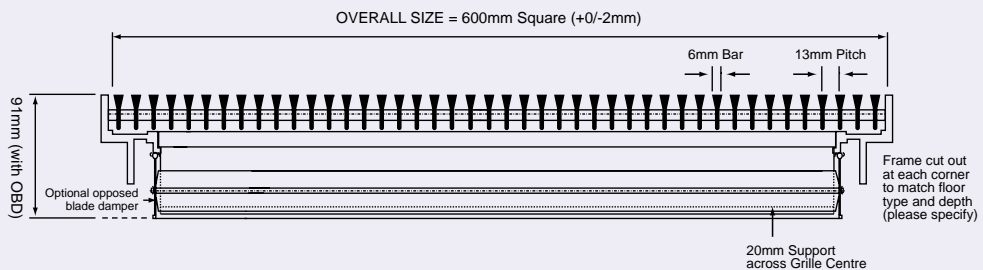

## Series GF Damper Options

On the standard frame Type 6 a Slot damper is available as an engineered solution for balancing purposes. The damper is easily adjusted by loosening the pozidrive lock screw in the centre of the grille (accessible between the bars). Pass a screwdriver through the third slot from the edge of the frame and engage the point in the slot on the sliding top plate. Push either way to obtain satisfactory airflow. The damper may then be locked in position using the lock screw. As an alternative Steel or Aluminium opposed blade type dampers (Ref: DM or DA) are optionally available on frame type 6. The only volume control option for Frame types 1, 2 & 3 is opposed blade.



Slot Damper...Ref. DH

View through centre of grille with the bars cut away

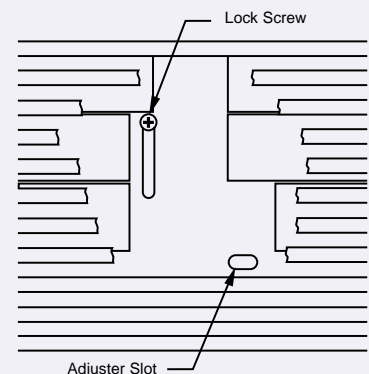

#### Slot Plate Damper Adjustment



# SERIES GF

## Series GF Options

### Opposed Blade Damper (Lockable)...Ref: DAL

The aluminium opposed blade damper can also be specified with a locking device to prevent tampering. Once the damper is balanced the locking screw at the back of the damper can simply be tightened with a screwdriver

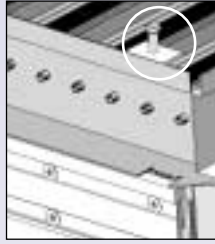

### Alignment Pips...Ref: P

Where units are fitted in linear banks or rows special alignment pips are required (2 each side) to ensure accurate spacing between each grille.

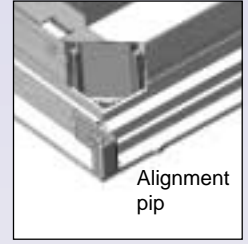
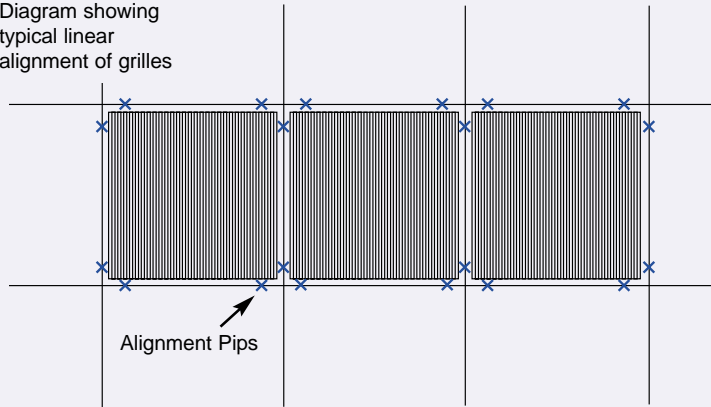

Diagram showing typical linear alignment of grilles



## Sizing Data

### SERIES GFX/600/6

### FRAME TYPE 6

Total Volume l/s		50		100		150		200		250		300		350		400		450		500	
Static Pressure /NC Level	No Damper ΔP-NC	<1.0	<15	<1.0	<15	<1.0	<15	<1.0	<15	<1.6	<15	2.3	<15	3	<15	4	<15	5	15	6	20
	Damper Full Open	<1.0	<15	<1.0	<15	1.5	<15	2.6	<15	4.0	15	6.0	20	8	25	10	25	13	30	16	30
	Damper 75% Open	<1.0	<15	1.0	<15	2.3	15	4.0	20	6.0	25	9.0	25	13	30	16	30	19	35	24	40
	Damper 50% Open	<1.0	<15	1.9	15	4.2	20	7.5	25	11.0	30	17.0	30	23	35	31	40	37	>40	48	>40
	Damper 25% Open	2.0	15	5.0	20	11.0	25	20.0	30	30.0	35	46.0	35	60	40	82	40	100	>40	130.0	>40
	Damper Closed	4.0	25	16.0	30	36.0	40	64.0	>40	95.0	>40	141.0	>40	180.0	>40	240.0	>40	300.0	>40	380.0	>40
Throw (m) 1st Figure to 0.5m/s 2nd Figure to 0.25m/s	Isothermal		0.15	0.45	0.85	1.0	2.8	1.8	3.2	3.0	5.0	4.0	7.0	5.2	10.0	7.0	>10.0	8.5	>10.0	>10.0	>10.0
	ΔT - 5K		0.12	0.40	0.62	0.82	1.80	1.40	2.20	2.20	3.40	2.90	4.65	3.70	6.50	4.95	7.80	6.0	10.0	7.50	>10.0
	ΔT - 10K		0.10	0.35	0.40	0.65	0.80	1.00	1.20	1.40	1.85	1.80	2.30	2.20	3.00	2.90	3.60	3.50	4.50	4.00	5.20
JET VELOCITY (M/S) ROTATING VANE			0.32		0.63		0.95		1.26		1.58		1.89		2.21		2.52		2.84		3.16

**DATA:** Based on unit with Hit & Miss Damper.

**THROWS:** First throw figure corresponds to 0.5m<sup>3</sup>/s, second figure to 0.25m<sup>3</sup>/s.

**NC LEVELS:** No room correction figures have been deducted.

For commissioning purposes using a 100mm dia rotating Vane Anemometer, take 12 random readings across the grille face and establish the mathematical average. Dividing this figure by 0.75 gives the true jet velocity for reference to the above table.

### SERIES GFX/600/1, 2 & 3

### FRAME TYPE1, 2 & 3

Total Volume l/s		50		100		150		200		250		300	
Static Pressure /NC Level	No Damper ΔP-NC	<1.0	<15	<1.0	<15	2.0	<15	3.6	<15	6.0	<15	9.0	20
	Isothermal	0.2	0.6	1.0	2.8	2.7	7.0	5.25	>10	9.0	>10	>10	>10
	ΔT - 5K	0.15	0.4	0.80	1.8	2.0	4.5	3.75	6.55	6.0	7.5	8.0	>10
	ΔT - 10K	0.1	0.2	0.64	0.8	1.3	1.7	2.25	3.10	3.2	4.6	4.5	6.4
JET VELOCITY (M/S) ROTATING VANE			0.42		0.80		1.40		1.70		2.10		2.80

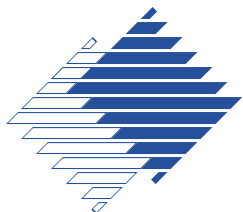

# SERIES GF

## Ordering Specification

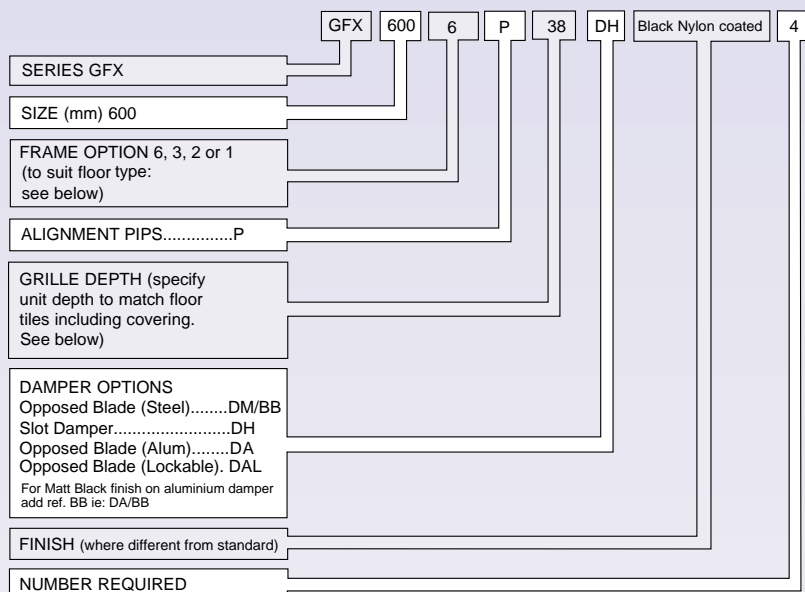

**Frame Type:** Frame type - Frame 6 has been developed to suit most popular floor systems. Frames type 1, 2 and 3 are limited in application. Our office can advise according to your floor make and model.

**Grille Depth:** Please specify the overall tile thickness (including any floor covering), the manufacturer and model of the raised floor and the maximum width of any stringers. Grille corners are factory manufactured anywhere between 50mm and 32mm to keep the grille face level with the adjacent floor tile and surface covering.

Min depth = 32mm / max = 50mm

**Alignment Pips** Please advise if units are fitted in linear banks or rows. Special pips will need forming at the edges of the grille frame to ensure accurate alignment and offset any manufacturing tolerances.

**Mill Finish:** Natural aluminium will resist corrosion in a clean atmosphere however the natural process of oxidation will gradually dull the surface appearance. The oxidised layer is a tough durable film that makes the unit highly resistant to further corrosion. Grille cleaning will not prevent oxidation and this oxidised layer can rub allowing the possibility of transfer to surrounding surfaces. Where this is critical alternative surface finishes such as a Nylon coatings are recommended

### FINISH

STANDARD FINISH: Mill Finish - Type GFX/600/6  
Brushed Mill Finish - Type GFX/600/1, 2 & 3

#### SPECIAL FINISHES:

- Brushed Finish (Frame type 6 only - Std on 1, 2 & 3)
- "Shadowline" with inner faces matt black and face brush finished
- Black Nylon coated to meet IBM specifications (This also insulates the unit in accordance with IEE regulations).
- Special Nylon coat colours may be available on request

NOTE: Aluminium Opposed Blade Dampers are Mill finish as standard. Steel Opposed Blade Dampers and Slot dampers are matt black

### FIXING

No fixing provided as standard. All units are "drop in type".

## Contact

### GILBERTS

Head Office and Works  
**GILBERTS (BLACKPOOL) LTD**  
Gilair Works, Clifton Road,  
Blackpool.  
Lancashire FY4 4QT.  
Telephone: (01253) 766911  
Fax: (01253) 767941  
e-mail: sales@gilbertsblackpool.com  
Web: www.gilbertsblackpool.com

