

# INTEGRATED LOUVRE SYSTEMS

OTHER RANGES AVAILABLE INCLUDE:

- HIGH PERFORMANCE LOUVRES
- MOVABLE BLADE LOUVRES
- SITE ASSEMBLY LOUVRES
- ACOUSTIC LOUVRES

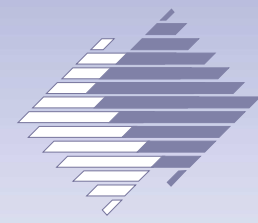

# GILBERTS

CI/SFB	
(57.7)	Xh
LOUVRES 2	
JAN 2006	

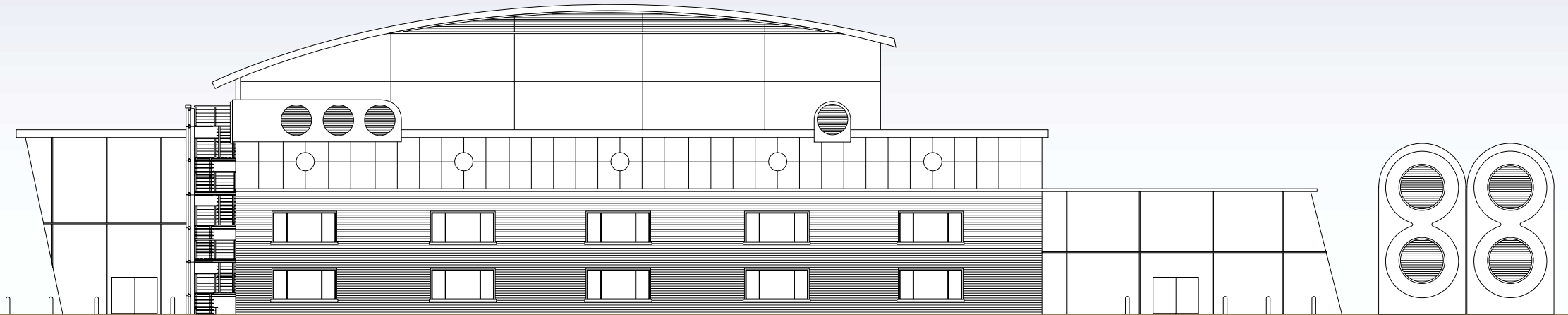

Clifton Road, Blackpool FY4 4QT Telephone: 01253 766911 Fax: 01253 767941  
Email: [louvres@gilbertsblackpool.com](mailto:louvres@gilbertsblackpool.com) Web: [www.gilbertsblackpool.com](http://www.gilbertsblackpool.com)

## INTEGRATED LOUVRE SYSTEMS

### STANDARD LOUVRES

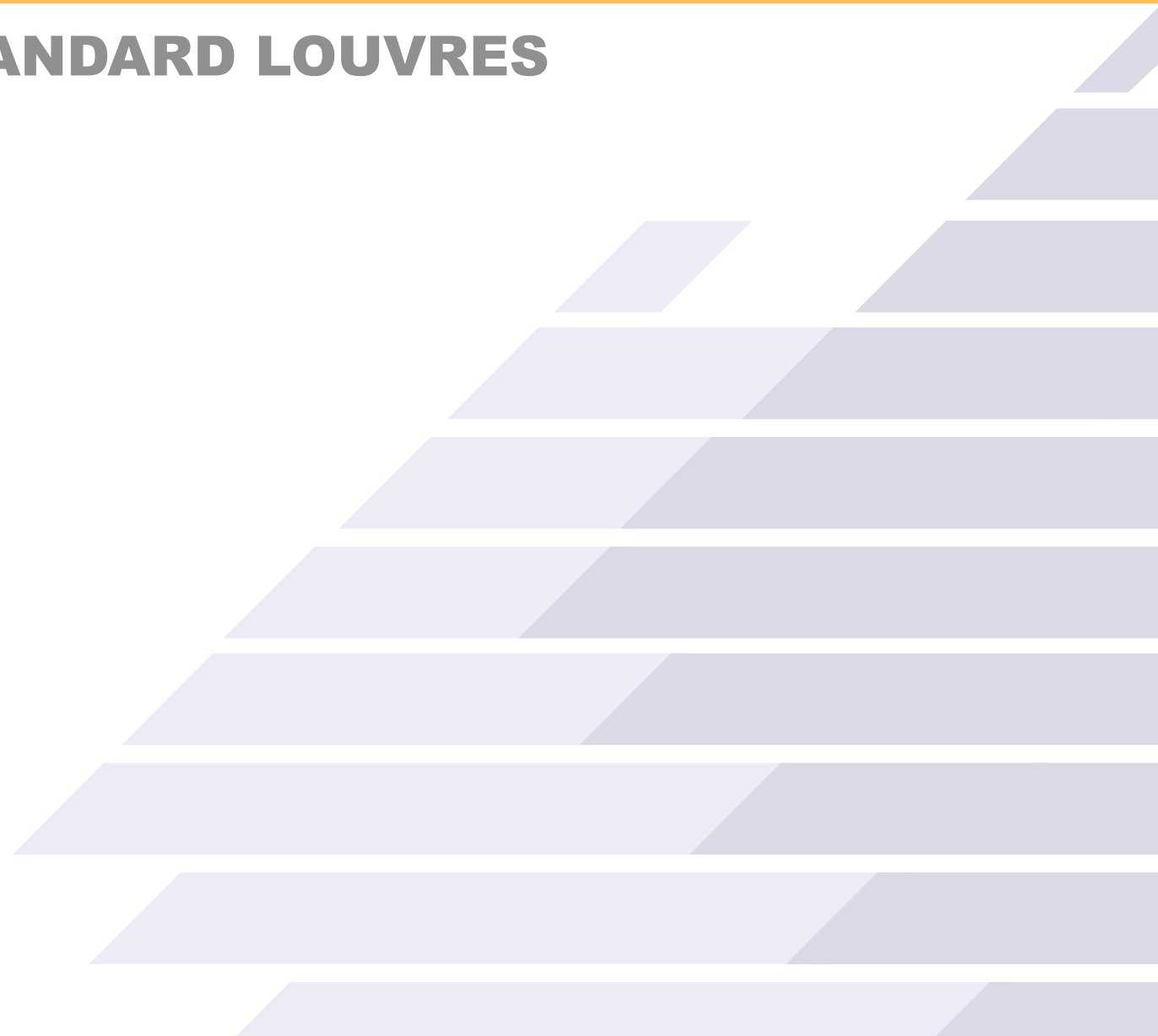
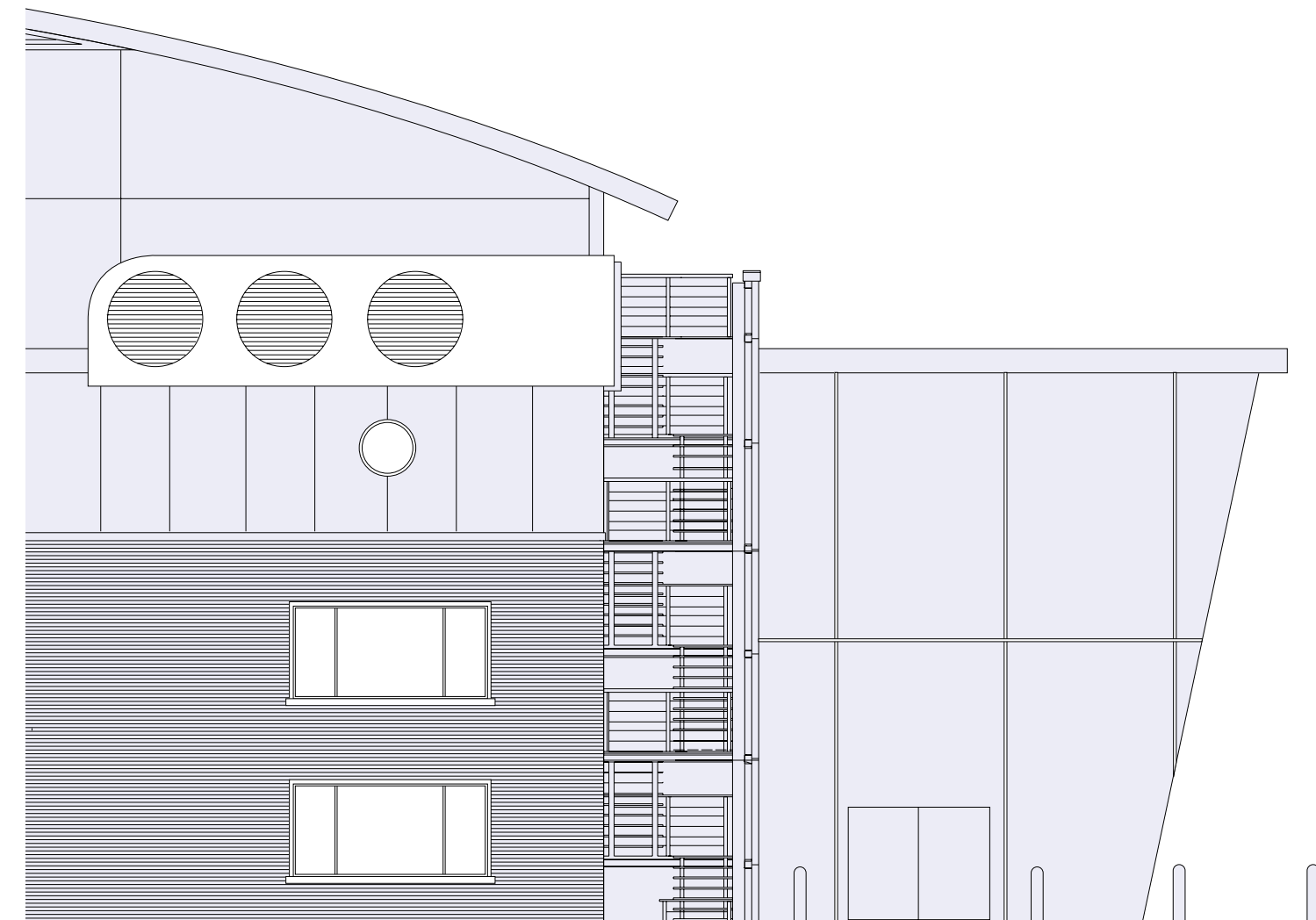



# 38mm PITCH LOUVRES

### 38mm PITCH LOUVRES

Series WG38 with its 38mm Pitch fixed Blades represents the smallest Louvre profile available in this system. This unit was designed to provide a neat and compact appearance for smaller Louvre applications combined with a convenient low size to weight ratio for easy handling. The profile of the Louvre ensures it offers good resistance to the ingress of rain even with its high 50% free area. Both flanged and recessed channel frame options can be selected along with standard bird guard, insect screen and weather cill accessories.

### SERIES OPTIONS

**WGF/38:** Comprises of 16 SWG Louvres on 38mm centres in a 32mm wide Flanged Frame.

**WGC/38:** Comprises of 16 SWG Louvres on 38mm centres in a 38mm deep Channel Frame.

### SIZE RANGE

Available sizes range from 100mm square up to 1750mm square in one unit. Above this size Louvres are supplied as multiple units with a continuous appearance for assembly on site.

(NB: On multiple assemblies the Frame/Flange size increases to 50mm angle).

LENGTH OF BLADE	VERTICAL MULLION WHEN REQUIRED
Up to 750	None
Over 750 - 1500	One
Over 1500	One every 750 pitch

FLANGE FACE FIXING DETAILS	
W-H Dim.	A Dim.
Up to 500	75.0
500 to 1750	150.0
1800 & over 150 & centre fixing holes	

NB: If Louvre is powder coated, Mullion pitch must be 500mm

### FIXING

**WGF/38:** Flange screw fixing using the pre-drilled 4mm countersunk holes. Flanges can be supplied un-drilled upon request.

**WGC/38:** Rear fixing cleats mounted off the housing frame to facilitate screw fixing into adjacent timber, masonry or duct.

### FINISH

The standard Louvre finish is mill finish (ie: un-treated). Polyester Powder Coatings, PVF and Anodised Finishes are also available on request.



# WG-38 SERIES

### WGF -38



### WGC -38

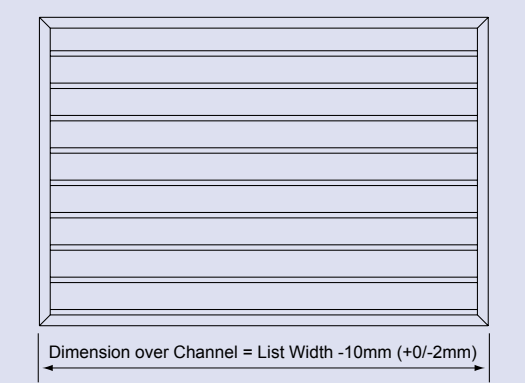

### WGF -38

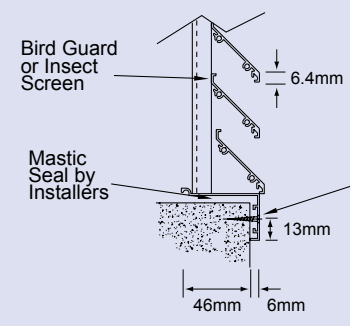

### WGC -38

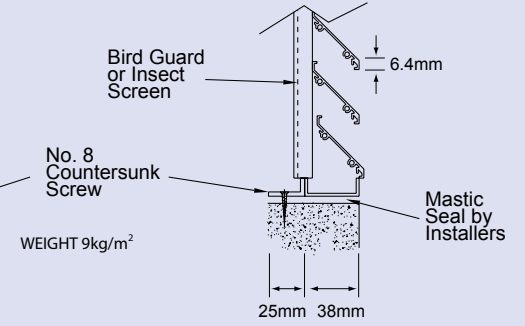

WEIGHT 9kg/m<sup>2</sup>

SERIES: <input type="checkbox"/>	Flanged - WGF Channel Frame - WGC	WGC
BLADE PITCH: <input type="checkbox"/>	38mm <input type="checkbox"/>	38
SIZE: <input type="checkbox"/>	(mm Width x Height) <input type="checkbox"/>	1200 x 800
OPTIONS: <input type="checkbox"/>	Birdguard - BG Insect Screen - IS	BG
EXTRA OPTIONS: <input type="checkbox"/>	Weather Cill - WC <input type="checkbox"/>	WC
SPECIAL FIXING OPTIONS: <input type="checkbox"/>	Rear Lug Fixing - RLF <input type="checkbox"/>	RLF
BLANKING PLATE OPTIONS: <input type="checkbox"/>	Standard - SBP Insulated - IBP	SBP
FINISH: <input type="checkbox"/>	(Please Specify) <input type="checkbox"/>	Mill Finish (Standard Finish)
NUMBER REQUIRED: <input type="checkbox"/>		15

# WG-75 SERIES

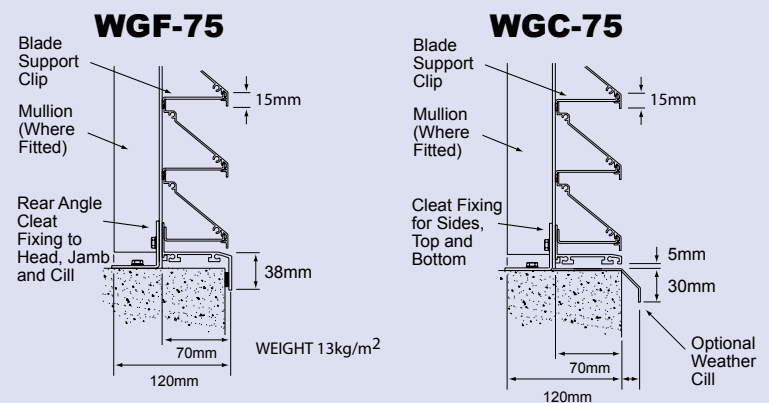
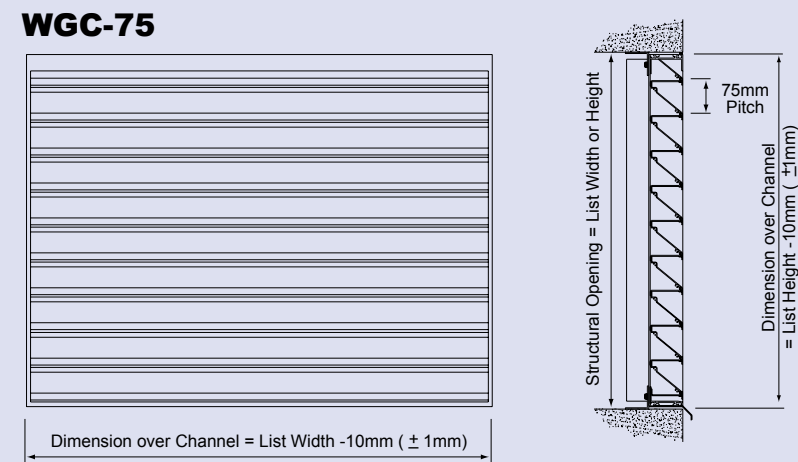
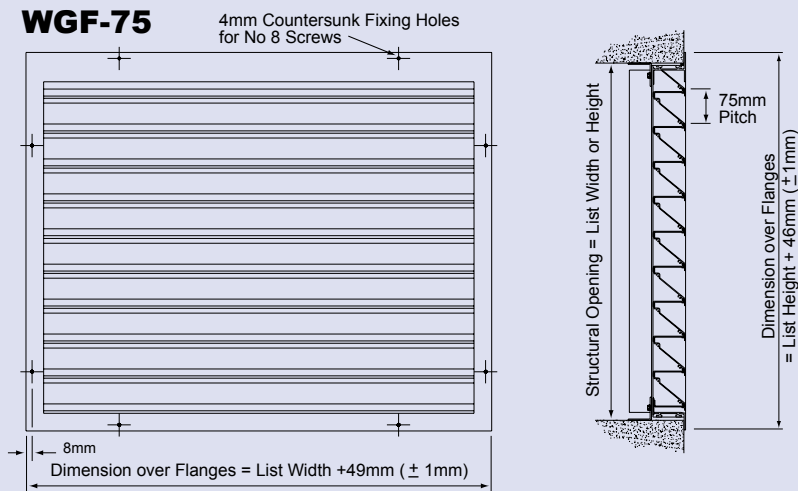

SERIES: <input type="checkbox"/>	Flanged - WGF	WGC
<input type="checkbox"/>	Channel Frame - WGC	
BLADE PITCH: <input type="checkbox"/>	75mm <input type="checkbox"/>	75
SIZE: <input type="checkbox"/>	(mm Width x Height) <input type="checkbox"/>	1200 x 800
OPTIONS: <input type="checkbox"/>	Birdguard - BG	BG
<input type="checkbox"/>	Insect Screen - IS	
EXTRA OPTIONS: <input type="checkbox"/>	Weather Cill - WC <input type="checkbox"/>	WC
SPECIAL FIXING OPTIONS: <input type="checkbox"/>	Rear Lug Fixing - RLF <input type="checkbox"/>	RLF
BLANKING PLATE OPTIONS: <input type="checkbox"/>	Standard - SBP	SBP
<input type="checkbox"/>	Insulated - IBP	
FINISH: <input type="checkbox"/>	(Please Specify) <input type="checkbox"/>	Mill Finish (Standard Finish)
<input type="checkbox"/>		
NUMBER REQUIRED: <input type="checkbox"/>		15



## 75mm PITCH LOUVRES

### 75mm PITCH LOUVRES

Series WG75 with its 16 SWG 75mm Pitch Louvres represents the principle building block for the Gilberts Louvre system. This unit utilises a 75mm blade, a profile which is equally suitable for both small and large Louvre Panels, allowing for a balanced appearance across a broad spectrum of sizes. The increased strength and rigidity of this blade over its 38mm counterpart has led to its use as the Design Basis for many of our other Louvre Products including single doors, double doors and louvre screens. In line with the smaller Louvres this series offers a high resistance to weather ingress combined with a good 50% free and both flanged and recessed channel frame options can be selected along with standard bird guard and insect screen accessories.

### SERIES OPTIONS

**WGF/75:** Comprises of 16 SWG Louvres on 75mm centres in a 38mm wide Flanged Frame.

**WGC/75:** Comprises of 16 SWG Louvres on 75mm centres in a 70mm deep Channel Frame.

### SIZE RANGE

Available sizes range from 300mm square up to 2000mm square in one unit. Above this size Louvres are supplied as multiple units with a continuous appearance for assembly on site.

(NB: On multiple assemblies the Frame/Flange size increases to 50mm angle).

### FIXING

**WGF/75:** Standard method is flange screw fixing using the pre-drilled counter sunk fixing holes and screws. Alternatively flanges can be supplied un-drilled upon request, with achieved via fixing cleats located at the back of the unit.

**WGC/75:** Self drill tapping bolt fixing through adjustable, fixing cleat angles located at the back of the unit.

### FINISH

The standard Louvre finish is mill finish (ie: un-treated). Polyester Powder Coatings, PVF and Anodised Finishes are also available on request.

LENGTH OF BLADE	VERTICAL MULLION WHEN REQUIRED
Up to 1000	None
1000 - 1600	One
Over 1600	One every 800

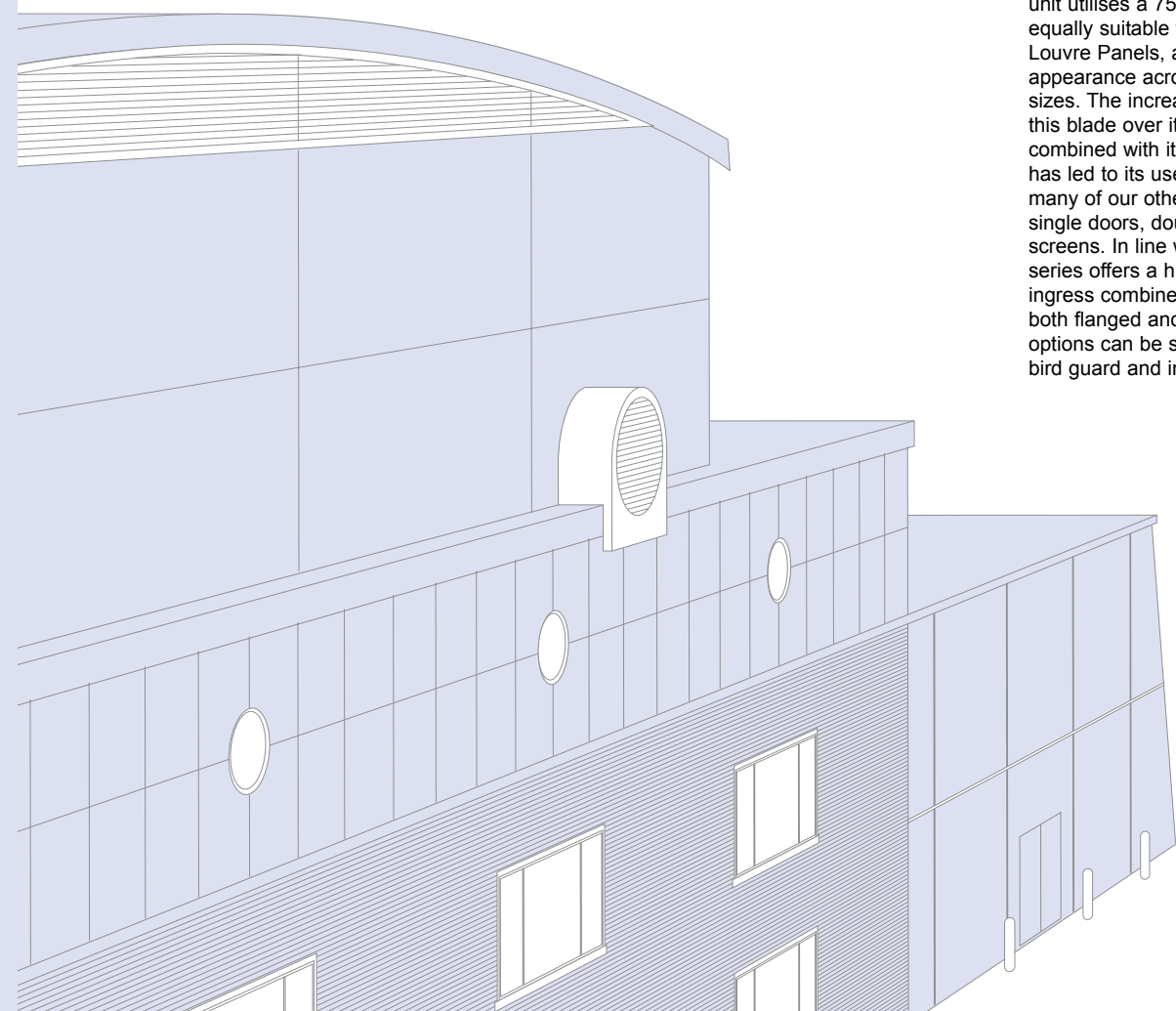



# 100mm PITCH LOUVRES

### 100mm PITCH LOUVRES

Series WG100 a 100mm Pitch Fixed Blade Unit represents the largest profile available in the Gilberts System. Utilising a 100mm heavy duty Louvre Blade the unit portrays a naturally 'Grand' appearance making it best suited for the larger Louvre applications. Manufactured from 16 SWG extrusion they are inherently strong and robust and offer good weather exclusion characteristics without sacrificing free area (50%). Both flanged and recessed channel frame borders can be selected along with optional Birdguard, Insect Screen and Weather Cill Accessories.

### SERIES OPTIONS

**WGF/100:** Comprises of 14 SWG Louvres on 100mm centres in a 38mm wide Flanged Frame.

**WGC/100:** Comprises of 14 SWG Louvres on 100mm centres in a 120mm deep Channel Frame.

### SIZE RANGE

Available sizes range from 600mm square up to 2500mm square in one unit. Above this size Louvres are supplied as multiple units for assembly on site.

LENGTH OF BLADE	VERTICAL MULLION WHEN REQUIRED
Up to 1000	None
1000 - 2000	One
Over 2000	One every 1000

### FIXING

**WGF/100:** Standard method is flange screw fixing using the pre-drilled countersunk fixing holes. Flanges can be supplied un-drilled upon request.

**WGC/100:** Screw fixing through pre-drilled holes located on the rear lip of the Louvre frame into the surround duct, timber or masonry.

### FINISH

The standard Louvre finish is mill finish (ie: un-treated). Polyester Powder Coatings, PVF and Anodised Finishes are also available on request.

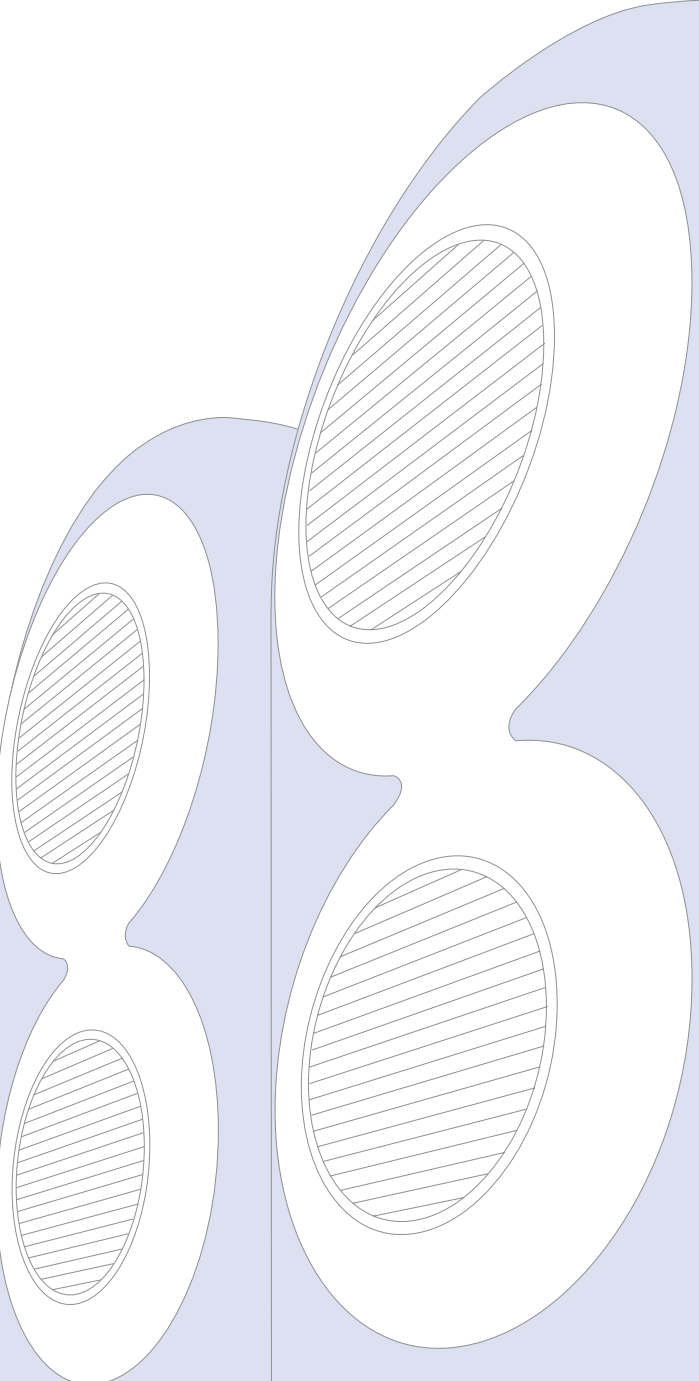
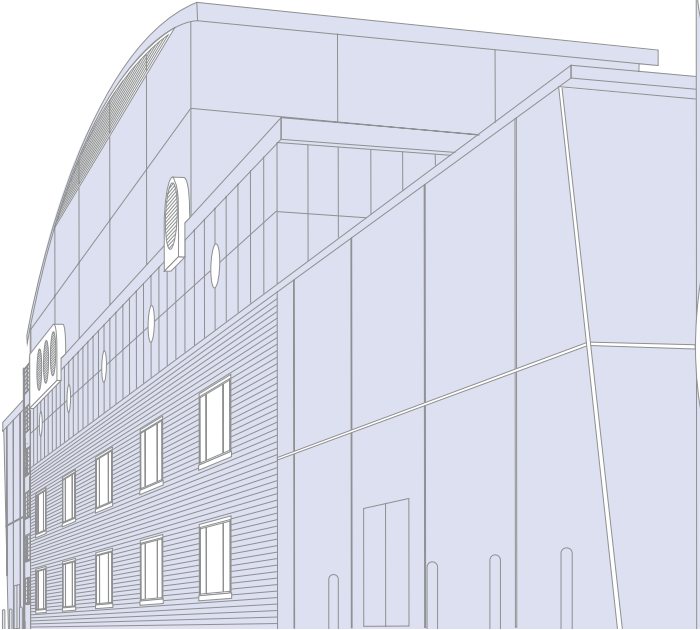

# WG-100 SERIES

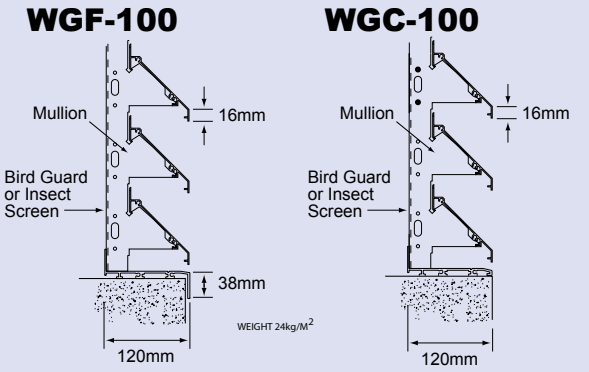
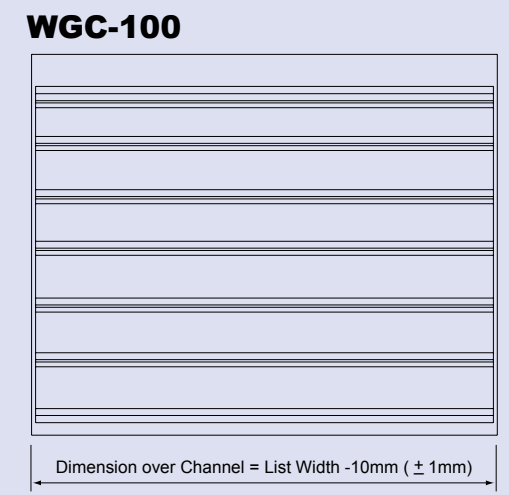
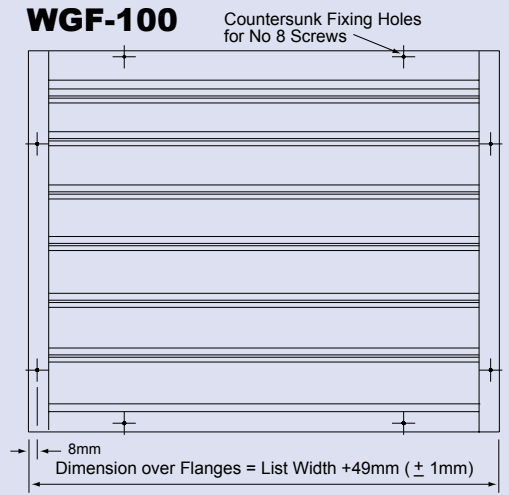

SERIES: <input type="checkbox"/>	Flanged - WGF	WGC
<input type="checkbox"/>	Channel Frame - WGC	
BLADE PITCH: <input type="checkbox"/>	100mm <input type="checkbox"/>	100
SIZE: <input type="checkbox"/>	(mm Width x Height) <input type="checkbox"/>	1200 x 800
OPTIONS: <input type="checkbox"/>	Birdguard - BG	BG
<input type="checkbox"/>	Insect Screen - IS	
EXTRA OPTIONS: <input type="checkbox"/>	Weather Cill - WC <input type="checkbox"/>	WC
SPECIAL FIXING OPTIONS: <input type="checkbox"/>	Rear Lug Fixing - RLF <input type="checkbox"/>	RLF
BLANKING PLATE OPTIONS: <input type="checkbox"/>	Standard - SBP	SBP
<input type="checkbox"/>	Insulated - IBP	
FINISH: <input type="checkbox"/>	(Please Specify) <input type="checkbox"/>	Mill Finish (Standard Finish)
<input type="checkbox"/>		
NUMBER REQUIRED: <input type="checkbox"/>		15

# WG 38/75/100 SERIES

## FIXING DETAILS - FLANGE FRAME

Either Face Flange Fixing or Rear Mounted Angle Brackets can be selected on Flange Border Units.

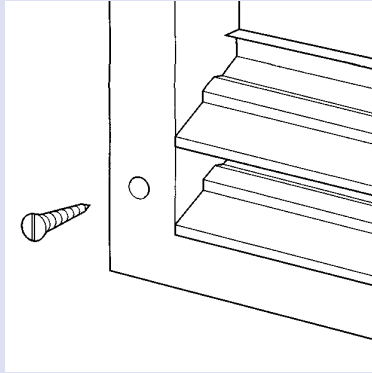

## FIXING DETAILS - CHANNEL FRAME

For WG38, 75 & 100 Series Fixing Angle Cleats can be situated on the appropriate centres at the rear of the Louvre Frame drilled suitable for Expansion Bolts (up to size M8) into structure. The slotted fixing allows for any necessary adjustment to suit fixing tolerances.

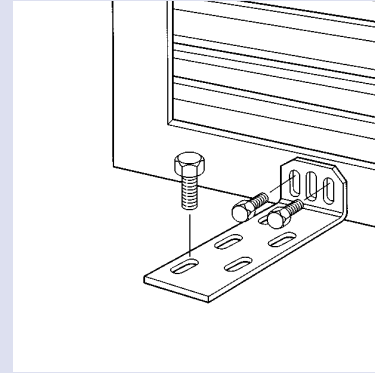

Cleats are available in 4 standard lengths; 50mm, 100mm, 150mm & 250mm and will be supplied in 3mm hot dipped galvanised mild steel. Unless otherwise stated 100mm lengths will be provided.

## EXPANSION JOINTS

Where Louvres are supplied for installation by others it is advisable that Compriband seal is inserted at all joints.

Where Gilberts are installing the Louvres Compriband will be fitted.

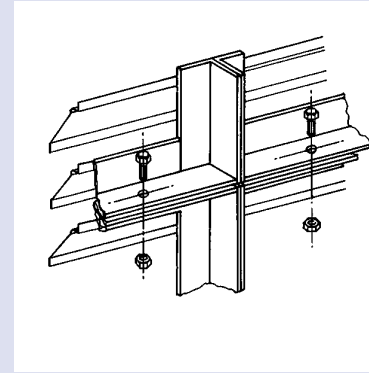

## CONCEALED ANGLE

The Concealed Angle Assembly design provides for virtually invisible jointing between Louvre panels. Accurate blade alignment on the face is insured by the support clips and pre-drilled assembly holes. Provision for Louvre expansion can also be made by applying Compriband Sealing/Expansion between the angles. (WG75 shown).

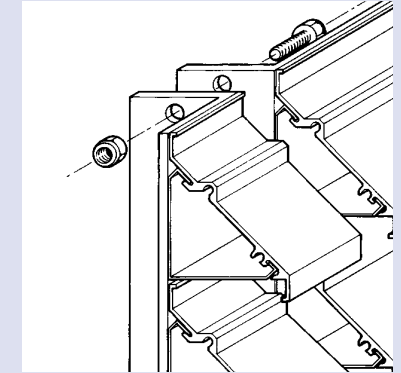

## VERTICAL ASSEMBLY

For assembly of vertical panels a reversed angle feature is utilised as illustrated. This provides for a invisible joint whilst maintaining the correct blade pitch. (WG75 shown).

## 38/75/100mm CONTINUOUS LOUVRES

### CONTINUOUS LOUVRE

For applications where larger Louvre assemblies are required such as for wall or rooftop screening and ventilation applications our Series WG38, 75 and 100 can be supplied any size in multiple panels, purpose built to assemble into a continuous Louvre Screen. Despatched with all the necessary fixing angles and bolts for their assembly the panels can be banked both horizontally and vertically and designed to incorporate additional features such as:

- Internal/External Mitred Corners
- Dummy, Blanked and Active Sections
- Horizontal and Vertical Blade Sections
- Single and double Hinged Continuous Appearance Doors

Unusual and irregular profiles can typically be catered for with accurate face alignment provided by the pre-fixed assembly holes and blade alignment pieces. Rear mounted Mullion Supports are provided for additional strength where required.

Our standard fixing and assembly details are illustrated herein. The individuality and

complexity of continuous screening applications will however require, in each case, the preparation of detailed manufacturing drawings to ensure that the unit not only meets all the clients requirements but is also easy to assemble, install and fix on site. Our Company has been specially tailored to provide this all inclusive service with:

- Initial Site Surveys to obtain construction work details
- Preparation of detailed manufacturing drawings in accordance with the clients requirements and the results of the initial Survey
- Final manufacture and appropriate finishing to blend or contrast, as required with the building structure
- Expert Site installation by our own team of skilled engineers

In this way a thorough and trouble free installation can be insured and our Louvre Team will be pleased to give any advice or guidance you may require for a particular application.



# LOUVRE DOORS

### LOUVRED DOORS

For applications where ventilation and access is required to Plant Room or Generator equipment Gilberts single and double leaf, inward or outward opening, Louvred Doors can provide an ideal solution. Designed for use both as stand alone units with Border Frame, or as part of a continuous Louvre Screen they constitute ready made units complete with all necessary accessories such as Door Stays, Mortice Locks, Barrel Bolts and, if required Birdguard or Insect Screens

### CONTINUOUS SCREEN DOORS

For use in continuous screens Louvre Doors incorporate a blade appearance frame and concealed pivot style hinges. This ensures that the continuous line of the Louvre is not compromised in any way. The standard blade profile is the 75mm unit as used on Series WG75 however 38 and 100mm pitches are available.

### SERIES OPTIONS

**WDS/75:** Single Hinged Louvre Door comprising 16 SWG Louvres on 75mm Centres  
**WDD/75:** Double Hinged Louvre Door comprising 16 SWG Louvres on 75mm Centres

### FIXING

Two alternative fixing methods are available on WD Louvred Doors as detailed.

### FINISH

The standard Louvre finish is mill finish (ie: un-treated). Polyester Powder Coatings, PVF and Anodised Finishes are also available on request.

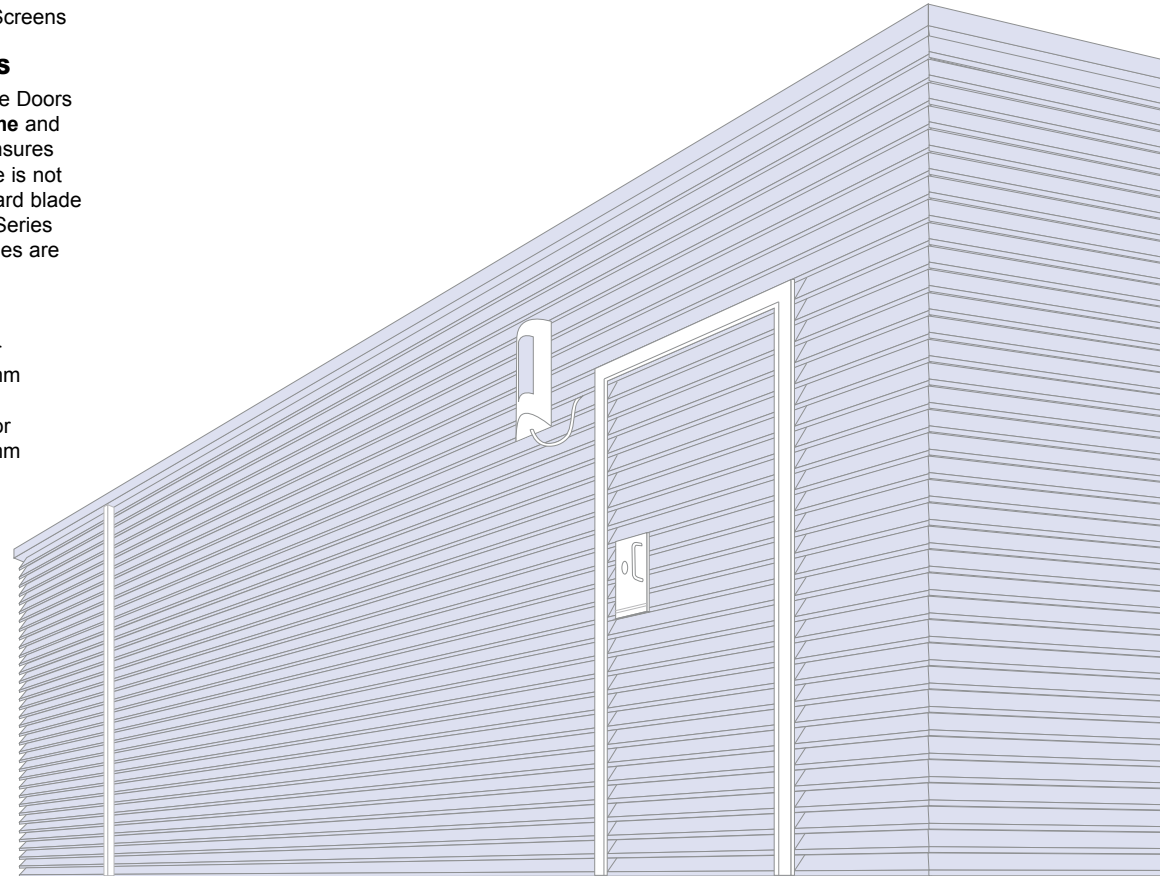

# WD SERIES

### WDS-75

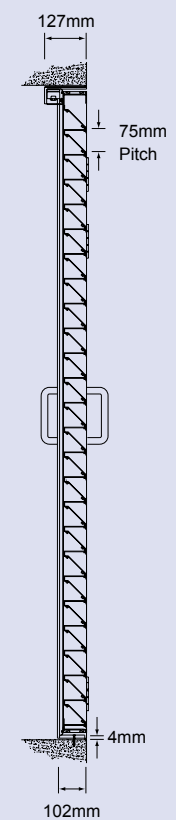
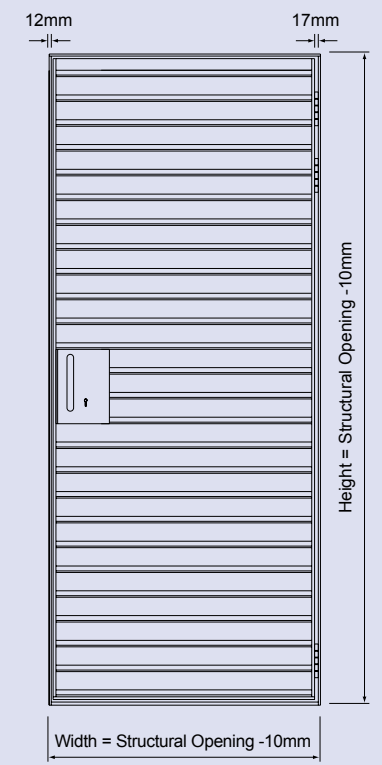

### SIZE RANGE

**WDS/75 (SINGLE DOOR):** Standard door panel to fit aperture openings 400 x 600 up to 1000 x 2100 angle. Leaf size = aperture opening -40 on width and -33 on height.

**WDD/75 (DOUBLE DOOR):** Standard door panel assembly to fit structural openings 1200 x 600 up to 2000 x 2100 angle. Leaf size = aperture opening -40 on width, and -33 on height. Clear opening = aperture width -112 and height -72

**Note:** For doors greater than listed sizes a 75 x 38mm box section outer frame is used to provide sufficient design rigidity.

### WDD-75

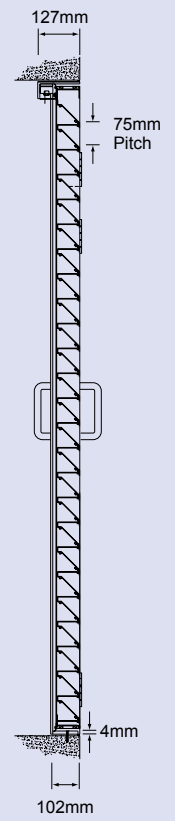
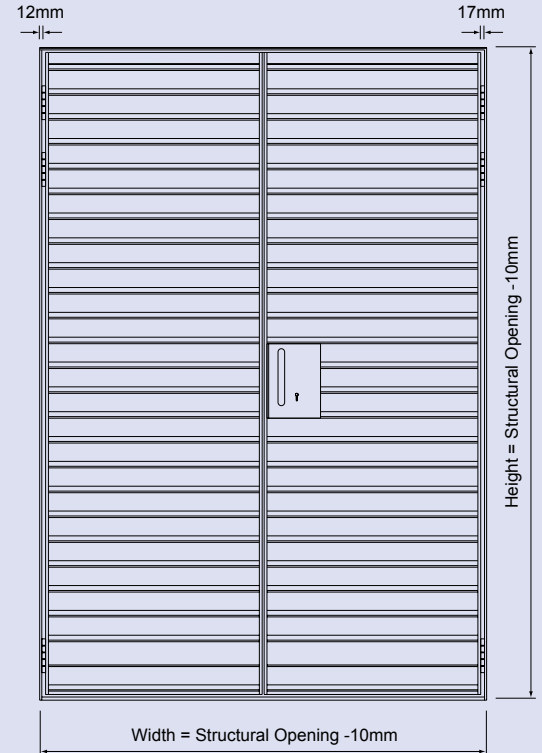

### FIXING ARRANGEMENT A

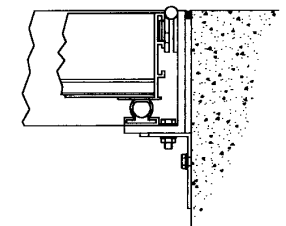

UNIT SECURED TO STRUCTURE THROUGH FIXING ANGLE CLEATS MOUNTED AT 600mm CENTRES AT REAR OF FRAME

### FIXING ARRANGEMENT B

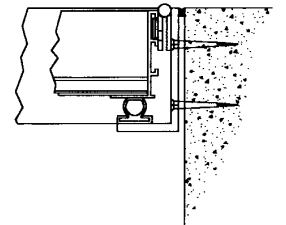

UNIT SECURED TO STRUCTURE WITH No.12 COUNTERSUNK SCREWS ON 600mm CENTRES THROUGH THE FRAME

SERIES: <input type="checkbox"/>	Narrow Border - WFD Wide Border - WBD	WFD
DOOR: <input type="checkbox"/>	Single - S Double - D	S
BLADE PITCH: <input type="checkbox"/>	75mm <input type="checkbox"/>	75
SIZE: <input type="checkbox"/>	(mm Width x Height) <input type="checkbox"/>	1200 x 800
OPTIONS: <input type="checkbox"/>	Birdguard - BG Insect Screen - IS	BG
OPENING DETAILS: <input type="checkbox"/>	Inward Opening - IO Outward Opening - OO	IO
HINGE DETAILS (Single door): <input type="checkbox"/>	Left hand Hinge - LH Right Hand Hinge - RH	LH
DOOR FIXING ARRANGEMENT: <input type="checkbox"/> A or B <input type="checkbox"/>		A
FINISH: <input type="checkbox"/>	(Please Specify) <input type="checkbox"/>	Mill Finish (Standard Finish)
NUMBER REQUIRED: <input type="checkbox"/>		15

# PH SERIES

## PH-38 BORDER STYLE 1

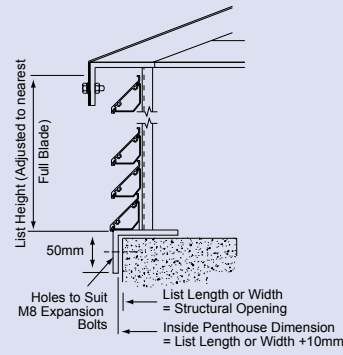

## BORDER STYLE 2

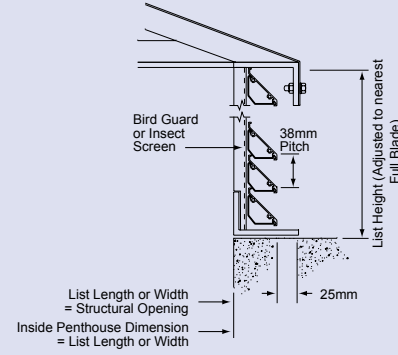

## PH-75

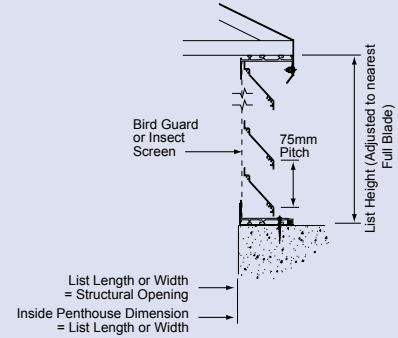
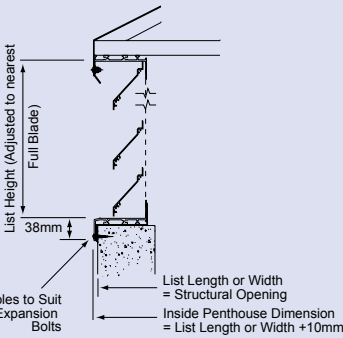

## PH-100

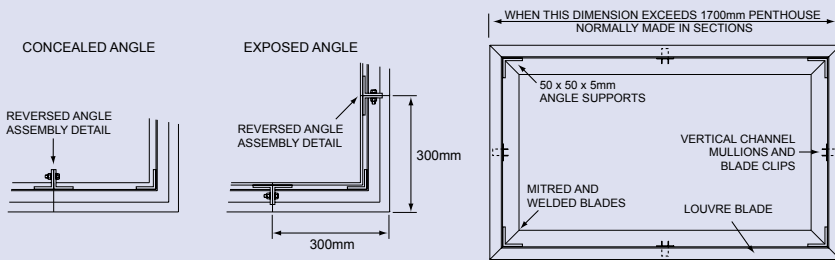
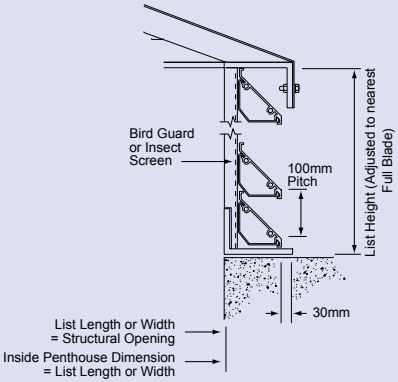
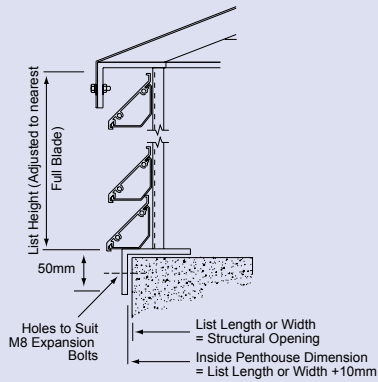

SERIES: <input type="checkbox"/>	PH <input type="checkbox"/>	PH
BLADE PITCH (mm): <input type="checkbox"/>	38, 75, 100 <input type="checkbox"/>	75
SIZE: <input type="checkbox"/>	(mm Length x Width x Height) <input type="checkbox"/>	1200 x 1200 x 800
OPTIONS: <input type="checkbox"/>	Insect Screen - IS <input type="checkbox"/>	IS
BASE BORDER STYLE: <input type="checkbox"/>	Border Style 1 - B1 Border Style 2 - B2	B1
FINISH: <input type="checkbox"/>	(Please Specify) <input type="checkbox"/>	Mill Finish (Standard Finish)
NUMBER REQUIRED: <input type="checkbox"/>		15



## PENTHOUSE LOUVRES

### PENTHOUSE LOUVRES

The PH Series is a range of roof mounting fixed Blade Louvre Housings suitable for air intake or discharge over ventilation shafts etc. The units are available in 3 blade formats based upon the WG Series of Louvre Panels and are supplied complete with continuous corners, removable sloping roof and birdguards. Supplied with alternative fixing borders to suit plinth or flat roof mounting the units offer a 50% free area performance combined with good weather characteristics.

### SERIES OPTIONS

**PH/38:** Comprises of 16 SWG Aluminium Louvres on a 38mm Pitch with rear mounted Birdguard screen. Insect screens available as an optional extra.

**PH/75:** Comprises of 16 SWG Aluminium Louvres on 75mm Pitch with rear mounted Birdguard screen. Insect screens available as an optional extra.

**PH/100:** Comprises of 16 SWG Aluminium Louvres on 100mm Pitch with rear mounted Birdguard screen. Insect screens available as an optional extra.

### SIZE RANGE

Available sizes range from 300x300x300mm upwards. For maximum unit sizes in one piece please refer to head office. Multiple assemblies can be supplied upon request.

### FIXING

The PH Series Penthouse Louvres are available with two types of base border options to suit either plinth or flat roof mounting. These borders are supplied with fixing holes to suit M8 expansion bolts on standard 600mm centres. Other fixing details available to order.

### FINISH

The standard Louvre finish is mill finish (ie: un-treated). Polyester Powder Coatings, PVF and Anodised Finishes are also available on request.

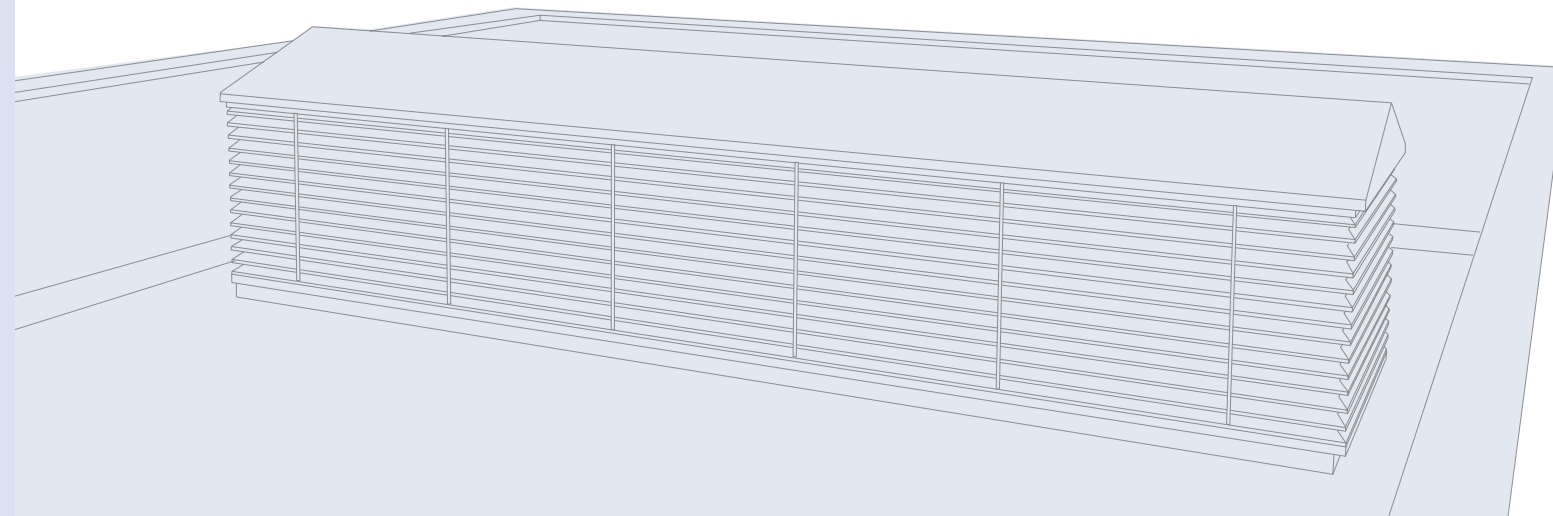



**SPECIAL LOUVRES**

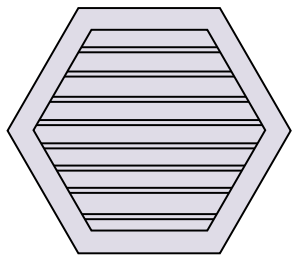

**HEXAGONAL**

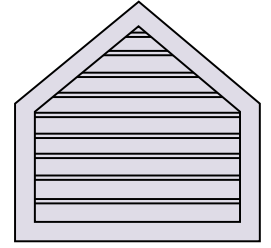

**POLYGONAL**

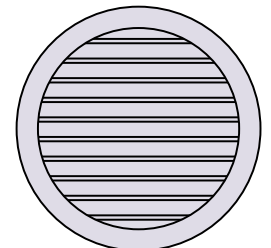

**CIRCULAR**

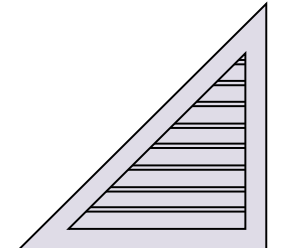

**RIGHT ANGLE TRIANGLE**

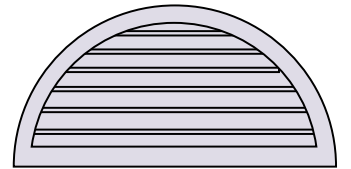

**SEMI-CIRCULAR**

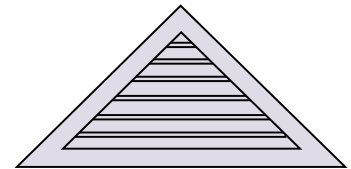

**EQUILATERAL TRIANGLE**

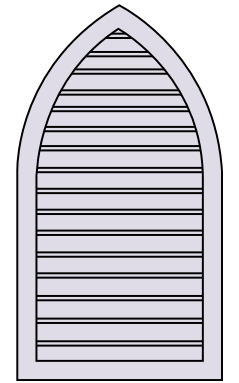

**ARCHED**

In addition to standard, square and rectangular patterns Gilberts can also fabricate special louvres to almost any practical design.

Circular, semi-circular and triangular designs are popular selections however other more unusual profiles such as gothic arch, polygon and even hexagonal have been supplied. For that special application in 38, 75 and 100mm pitch profiles please contact our louvre sales office.

# SIZING NOMOGRAM

## WG-38/75/100 SERIES

