



HEAT RECOVERY UNITS

DIRECT DRIVE · BELT DRIVE · BESPOKE



INTRODUCTION

Climate change is already having an impact on the environment and there is no doubt that the reduction of carbon emissions is paramount if we are to help preserve the world in which we live.

One way in which emissions can be reduced is by reducing energy consumption when heating and cooling buildings by incorporating heat recovery equipment. Instead of extracting the stale air and sending heated air to atmosphere energy recovery devices can be incorporated into the extract plant to recover a large proportion of the otherwise wasted heat which can then be transferred to the supply air stream.

Over the following pages we will demonstrate the ways in which heat can be recovered and how much energy can be saved.

CONTENTS

Thermal Wheel Heat Recovery

The most effective technology to reduce energy related cost in air handling units is the energy recovery wheel.



Page 4

Plate to Plate Heat Recovery

Plate type heat exchangers are utilised for both heating and cooling recovery in air conditioning, ventilation and processing technology.



Page 5

Runaround Coil Heat Recovery

Runaround coil systems have been used for many years for the purpose of heat recovery and are of particular use where air streams or plant are remote from one another.

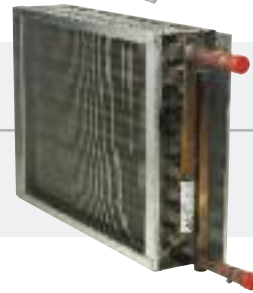

Page 6

NEVADA

HEAT RECOVERY

Features & Benefits

Component Specification

Performance & Electrical Data

Dimensional Data

Silencer Data

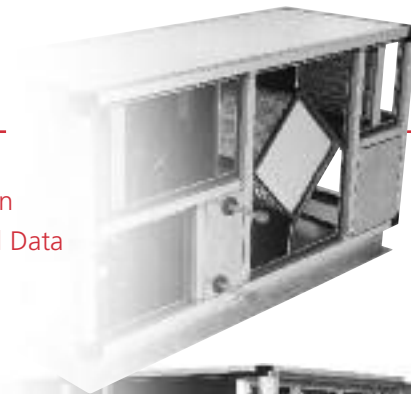

Page 8

Page 9

Page 10

Page 12

Page 15

Page 16

BESPOKE

HEAT RECOVERY

Features & Benefits

Component Section Data

Performance & Electrical Data

Typical Arrangements



Page 18

Page 19

Page 20

Page 22

Page 24

AIR HANDLING

SELECTION PROGRAM

Integrating computer aided design software with 3D visualisation tools and bespoke third party engineering selection programs, to deliver the complete engineered solution to meet your specific requirements.

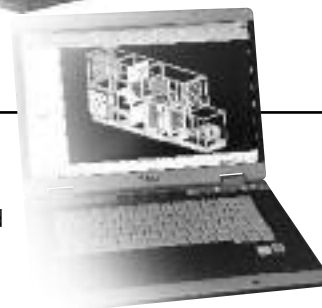

Page 26

Options & Accessories

A selection of products available from Fastlane to improve performance and control of Fastlane's Heat Recovery Air Handling units.

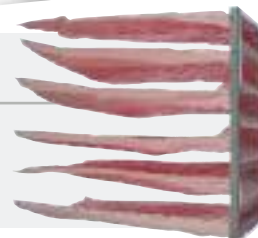

Page 28

Thermal Wheel Heat Recovery

The most effective technology to reduce energy related cost in air handling units is the energy recovery wheel.
The heat recovery wheel installed in a ventilation and air conditioning system

recovers the heat and moisture from one air stream and transfers it to the other air stream. It supplies a continuous flow of fresh air, providing a comfortable level of humidity at minimal ventilation cost.

Figure 1. Heat Recovery with Standard Rotary Heat Exchanger

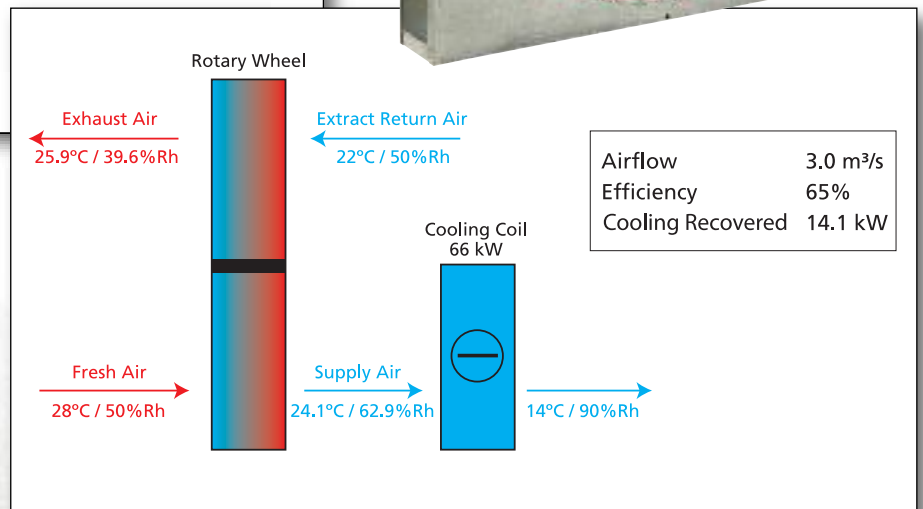
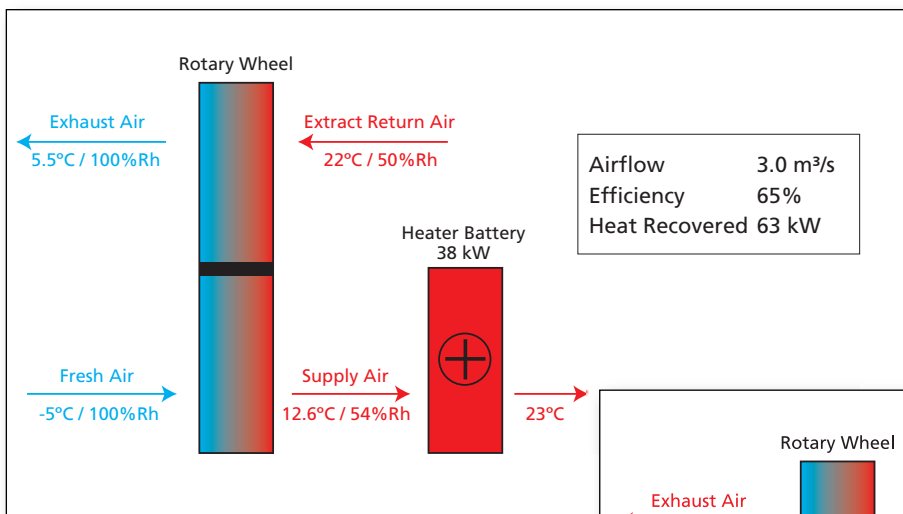

Figure 2. Cooling Recovery with Standard Rotary Heat Exchanger

Although this is a standard rotary exchanger under the conditions shown in Figure 1., a certain amount of moisture is also recovered from the extract air and passed to the supply air stream. If the above duty were performed by a plate heat exchanger the off temperature of 12.6°C would remain unchanged but the relative humidity figure would only be 27.6%. As shown in Figure 1. the actual heat recovered, including moisture recovery, is 83.6 kW. The advantage under

these conditions is that the air is less dry and if humidification is required a reduction in running costs will be available.

Under the conditions shown in Figure 2 the cooling recovery is identical to the duty of a plate heat exchanger as no moisture is transferred from the supply air to the extract air. If a Sorption rotary exchanger is used a considerable amount of moisture would be transferred with a subsequent increase in cooling recovery.

Plate to Plate Heat Recovery



Plate type heat exchangers are utilised for both heating and cooling recovery in air conditioning, ventilation and processing technology.

By means of the heat exchanger two air streams of differing characteristics are forced to pass by each other in either opposite directions or parallel to each other through thin specially structured plates without any contact between the two air streams. The numerous plates in the heat exchanger cause the energy transfer. The two air streams do not mix, consequently the transfer of humidity, pollution, bacteria and odour is avoided.

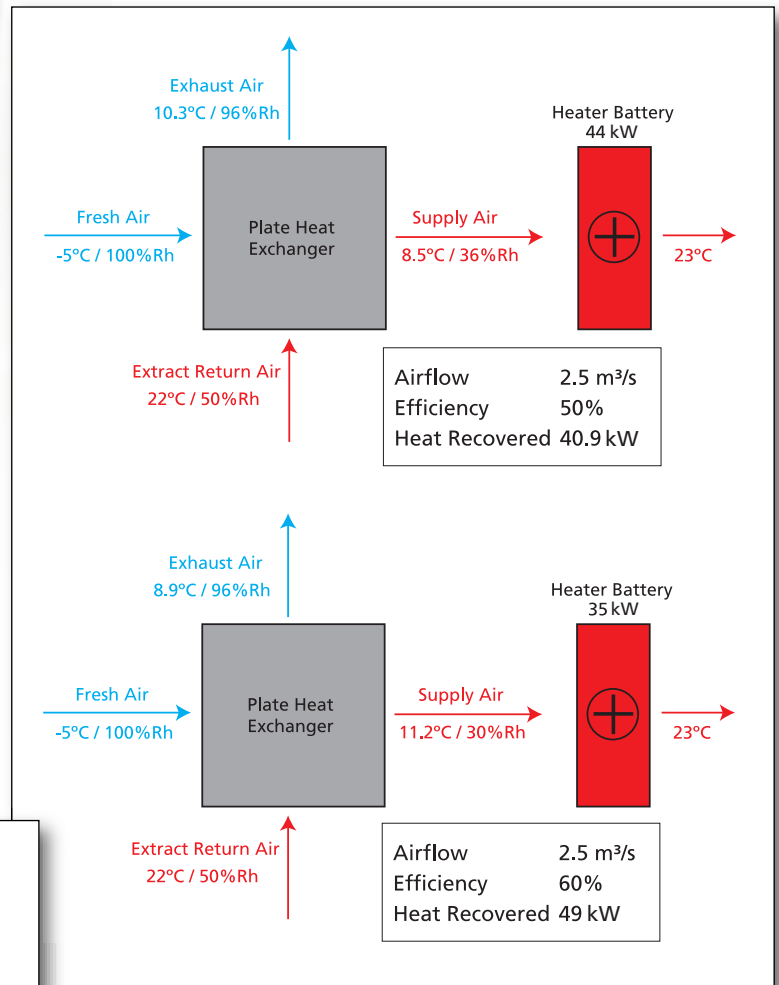

Figure 3. Heat Recovery with Plate Heat Exchanger

Figures 3 and 4 illustrate the effect of the heat exchanger efficiency for both heat recovery and cool recovery applications.

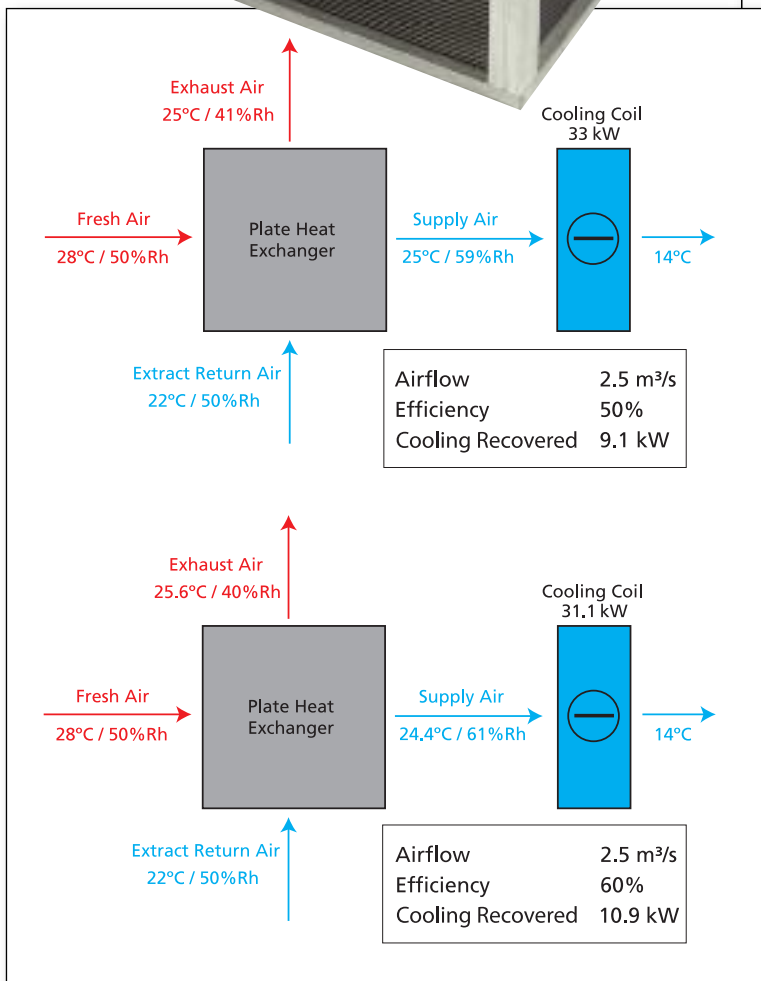

Figure 4. Cooling Recovery with Plate Heat Exchanger

$$\text{Efficiency of Heat Exchanger} = \frac{\text{Rise in cold air temperature}}{\text{Temperature difference between warm and cold air at entry}}$$

$$= \frac{t22 - t21}{t11 - t21}$$

- t11 = Temperature of warm air entering heat exchanger
- t21 = Temperature of cold air entering heat exchanger
- t22 = Temperature of cold air leaving heat exchanger

If warm air volume is greater than cold air volume the efficiency will be increased. If cold air volume is greater than warm air volume the efficiency will decrease.

Runaround Coil Heat Recovery

Runaround coil systems have been used for many years for the purpose of heat recovery.

A runaround coil heat recovery system is essentially self contained as shown in Figure 5. A matched pair of coil heat exchangers are piped together in a continuous loop through which the heat exchange medium water or a water and anti-freeze mix flows. A pump ensures that the medium keeps flowing at a constant rate.

Because the system is sealed it can transfer heat energy from contaminated exhaust air to supply air without degrading the quality of the supply air.

This type of system can provide up to 60% heat recovery, they are particularly cost effective in settings that generate high temperatures such as kitchens, laundries, paint spray booths and any process that generates waste heat. The advantage of this system is it can be used when the supply and extract systems are remote from each other, as there is no limit on the distance between the systems.

There are 3 types of coils available; Copper tube / Aluminium fins, Copper tube / Copper fins and Copper tube / Copper electro tinned fins. The pump set can be provided either fitted within the Air Handling Unit or for remote mounting.

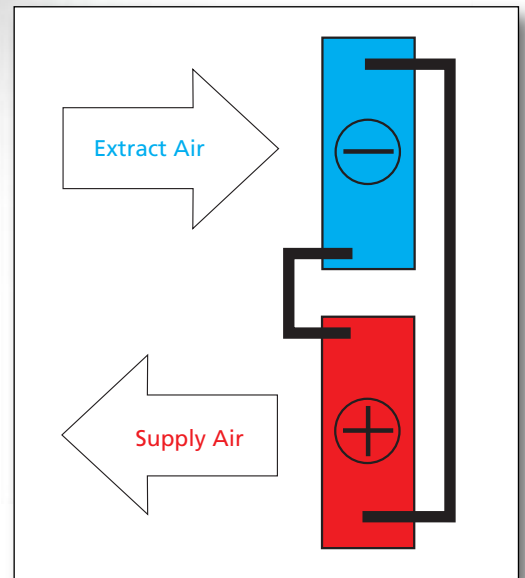

Figure 5. Runaround Coil Systems



NEVADA

HEAT RECOVERY

The Nevada range of direct drive heat recovery units provide a solution for most applications which require a small unit and low air volumes and are also suitable for cooling recovery.

Units are manufactured with a rigid pentapost construction and are suitable for either internal or external mounting dependant upon application.

Units are available in two standard arrangements; Side by Side or Double Deck to suit space available with a selection of five standard models and a duty range of up to 1.0 m³/s.

Each standard Nevada HRU comprises of direct driven centrifugal fans for supply and extract, plate to plate recuperator, Electric Heater Battery or L.P.H.W. Coil, and G4 pleated panel filter in both airways.

The Nevada HRU range can be enhanced through a wide variety of optional equipment to cater for customer applications including standby fans on extract, bypass dampers, silencers, control panels, washable filters and volume control dampers.



NEVADA

HEAT RECOVERY

FEATURES & BENEFITS

Construction

The Nevada range offers a flexible modular construction which provides an easier on site building option. All units can also be supplied in flat-pack form where access to plant room or site location is restricted.

The frame structure enables added versatility by providing hanging, stacking or joining configuration variations.

The unit has a rigid aluminium framework, with purpose built corners for added strength. Double skinned panels offer a smooth clean line with the outer panel available in Galvanised Sheet Steel or Plastisol coated steel.

For ease of installation and maintenance each unit comprises slide rails and either top, bottom or side entry points offering easy access to components with minimal effort.

Performance

Flexibility in performance is achieved by the use of fully speed controllable fans which lead to added efficiency and excellent performance characteristics for air volumes of up to 1.0 m³/s.

Design

The range offers two standard arrangements; Side by Side and Double Deck and incorporate forward curved single or double inlet centrifugal fans, plate to plate recuperator, electric or hot water heating coils and pleated panel filters within both air streams. Backward curved centrifugal fans with energy efficient EC/DC motors are available. Condensation drain trays are fitted in all units and a wide range of heater output options are available.

Units are acoustically and thermally lined with additional acoustic treatment available on request.

Flexible in design with internal or external mounting units the Nevada range also boasts a comprehensive range of accessories including matching silencers and summer bypass dampers suitable for motorised operation.

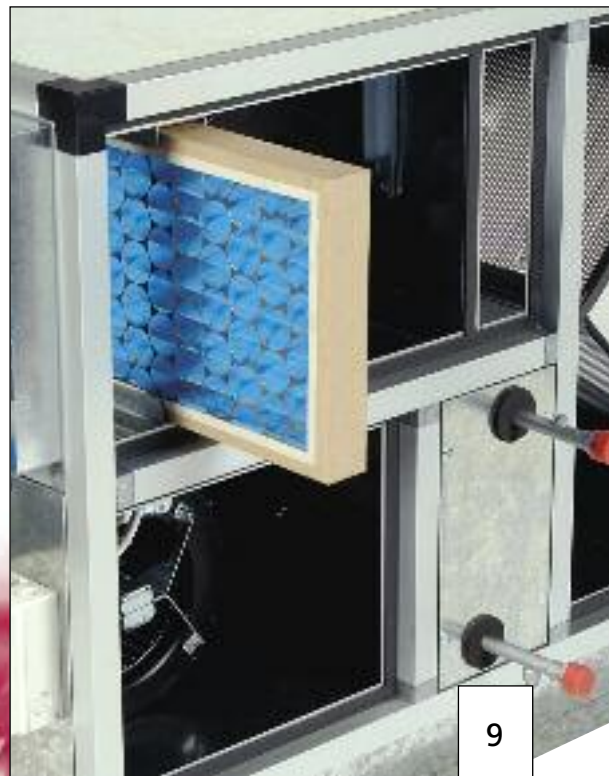

NEVADA

COMPONENT SPECIFICATION

HEAT RECOVERY

Casing

The NEVADA units are suitable for either internal or external mounting arrangements. Although all units have pre-galvanised casings as standard, they can be supplied with plastisol coated steel outer skins upon request.

Panels are flush mounted into the unit framework rebates on a crush resistant closed cell neoprene sealing gasket, which provides an air seal between the panel and the component section. Gaskets are chemically and biologically inert and meet all requirements of DW 144.

Internal Units

The standard NEVADA Air Handling units have an AA25 anodised finish extruded aluminium section, constructed from a 30mm framework with a wall thickness of 1.5mm. The mullion section is used between access panels and where panels are joined as part of the pentapost framework and is constructed to the same specification.

The specially designed durable corner sections for the 30mm framework are manufactured from black high density glass reinforced nylon, providing a framework of strength and rigidity, onto which all internal components and casing panels are mounted.

All access panels are held firmly in place on the framework by means of fasteners, which exert pressure evenly between the panels and sealing gasket.

Access panels are lift off type with Allen key operated 'quick release' fasteners, while all other fixed panels are retained with roofing bolts, sealed using a high modulus acetoxycure silicone sealant to BS 5889 Type B. Access panels can be hinged if required, enabling servicing of the unit without completely removing the panel. Handles are fitted to access panels for ease of handling and removal from the unit framework, which facilitates access to components for regular maintenance. N.B. Fan access and filter removal can be from top, bottom or both sides.

Infill panels are double skinned, constructed from 1.0mm thick pre galvanised sheet steel to BS 2989 Z2 inner and outer skins, using a sandwich construction enclosing 25mm of 65kg/m³ mineral wool insulation, which is completely encapsulated between the steel sheets to provide acoustic and thermal insulation.

External Units

Infill panels are double skinned, the inner skin constructed from 1.0mm thick pre galvanised sheet steel to BS 2989 Z2. Outer skins, weather caps and external louvres are manufactured from 0.9mm Colorcoat HP200 material, British Steels roofing and cladding steel with 200 micrometre high performance plastisol coating, on a Galvalite hot dip zinc coated substrate to BS EN 10 147.

All units are fitted with a weather guard and intake or discharge louvres incorporating bird mesh screens to protect the air inlet and discharge openings.

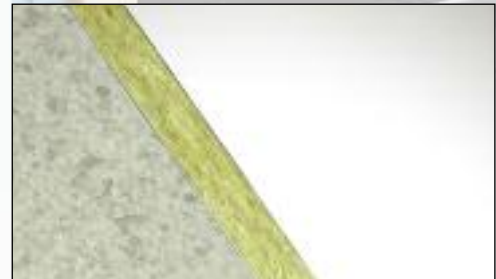

Fans, Motors & Filters

The fans mounted onto a diaphragm plate are double inlet double width forward curved centrifugal and housed in a purpose designed scroll with integral deep drawn inlet rings to facilitate maximum efficiency. All fans are suitable for 230V/1Ph/50Hz electrical supply. For 230V/1Ph/60Hz please enquire. The motors are isolated from the unit case via anti-vibration mounts fitted between the motor mounting arm and the fan scroll.

Panel filters are 50 or 100mm deep disposable type to Grade G4, in accordance with BS EN 779 1993 (EU4). They are for side withdrawal, mounted into the unit on slide rails, which are manufactured from pre-galvanised sheet steel to enable filter replacement. Filters are manufactured from pleated media consisting of reinforced non-woven fibres, with expanded diamond grid to provide maximum support. Pleating the media increases the filtration area to more than three times that of the face area, providing high dust holding capacity and low pressure loss. The pleat pack is encased in a water resistant lattice cardboard frame.

Heaters

Electric Heater Batteries (E.H.B.)

Elements are constructed from Nichrome 5 spiral resistance wire surrounded by magnesium oxide powder and sheathed in stainless steel. The elements are mounted on a galvanised sheet steel terminal housing. All electric heaters are fitted with high temperature thermal cut out protection for wiring into the control circuit.

A control system must be provided to ensure the heater is not activated when there is no airflow and the fan runs on after the heater has been switched off, dissipating any residual heat. It is recommended that a fan run on timer be incorporated within the controls to prevent possible heat damage, as well as an airflow switch.

Hot Water Heating Coils (L.P.H.W.)

Coils are constructed from seamless drawn copper tube to BS 2871 mechanically expanded into aluminium fins with die formed self spacing collars. The coil casing is formed from heavy gauge galvanised sheet to BS 2989 to make a rigid assembly, with BSP(M) pipe fittings on coil flow and return connections. Tube end plates have die formed collared holes to allow expansion and contraction of the tubes without damage. Coil sections are fitted into the units on pre-galvanised slide rails for ease of assembly and withdrawal.

All coils are subjected to an air under water test to 17 bar during manufacture.

Plate to Plate Recuperator

Plate heat exchangers are important elements in saving energy and are used in Fastlane air handling units to lower energy consumption and minimise damage to the environment. Efficiencies between 40% and 75% can be achieved depending on air temperatures and volumes through the exchanger.

In the plate heat exchanger warm extract air and the cool fresh air, separated by thin aluminium plates, pass each other in cross-flow. No mixing of the two air streams occurs, preventing the transmission of dirt, odours and moisture. Heat is transmitted from extract air to fresh air by conduction as a result of the temperature difference between the two air streams. Warm extract air is cooled down, cool fresh air is heated. Plate heat exchangers can be supplied with a summer by pass damper to prevent incoming fresh air being heated by the extract air.

For special applications the exchanger and casing can be corrosion protection coated or the entire unit supplied manufactured from high grade stainless steel. The plate heat exchangers have no moving parts and operation is 100% reliable.

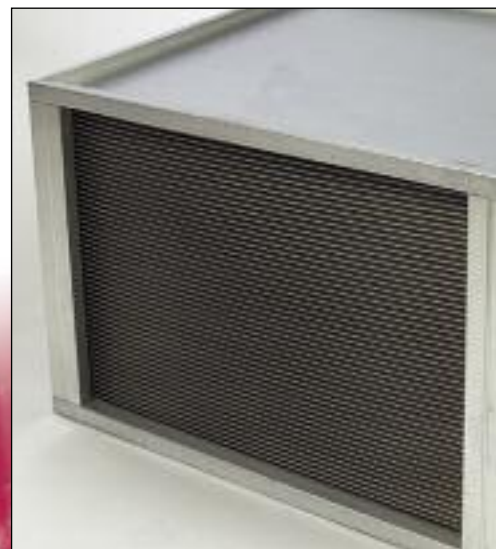
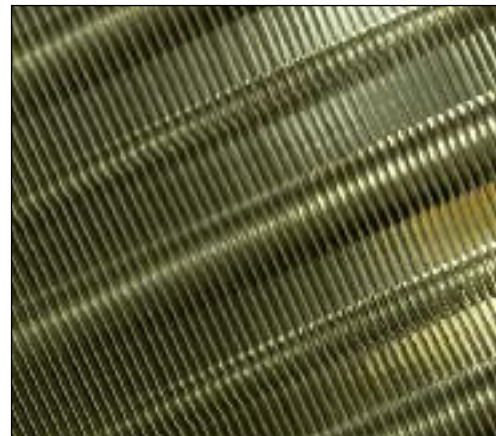
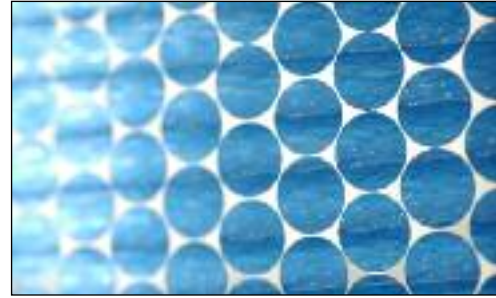

PERFORMANCE & ELECTRICAL DATA

HEAT RECOVERY

Standard Unit with Panel Filters, Electric Heater, Recuperator and Fans

Model	Airflow m ³ /s @ static pressure Pa										
	0	50	100	150	200	250	300	350	400	450	500
FFH-HRU-1-SF	0.250	0.211	0.167	0.111	0.019	-	-	-	-	-	-
FFH-HRU-2-SF	0.394	0.347	0.292	0.222	0.150	0.069	-	-	-	-	-
FFH-HRU-2-HP	0.517	0.486	0.444	0.394	0.328	0.264	0.181	0.125	0.083	0.044	-
FFH-HRU-3-SF	0.667	0.633	0.583	0.556	0.486	0.411	0.272	0.153	0.111	0.056	-
FFH-HRU-3-HP	0.740	0.686	0.639	0.589	0.514	0.425	0.306	0.208	0.139	0.069	-
FFH-HRU-4-SF	0.850	0.783	0.740	0.689	0.600	0.511	0.375	0.250	0.156	0.069	-
FFH-HRU-4-HP	0.947	0.903	0.861	0.806	0.736	0.683	0.592	0.500	0.383	0.256	0.179
FFH-HRU-5-SF	1.028	1.000	0.947	0.889	0.833	0.778	0.689	0.583	0.444	0.306	0.194

SF = Standard Fan HP = High Pressure Fan

Standard Unit with Panel Filters, LPHW Heater, Recuperator and Fans

Model	Airflow m ³ /s @ static pressure Pa										
	0	50	100	150	200	250	300	350	400	450	500
FFH-HRU-1-SF	0.243	0.208	0.174	0.125	0.042	-	-	-	-	-	-
FFH-HRU-2-SF	0.385	0.343	0.293	0.231	0.153	0.075	-	-	-	-	-
FFH-HRU-2-HP	0.500	0.461	0.425	0.383	0.331	0.253	0.194	0.139	0.100	0.050	-
FFH-HRU-3-SF	0.656	0.617	0.586	0.550	0.488	0.417	0.283	0.167	0.117	0.078	-
FFH-HRU-3-HP	0.717	0.672	0.625	0.583	0.508	0.428	0.319	0.228	0.153	0.078	-
FFH-HRU-4-SF	0.806	0.758	0.722	0.656	0.583	0.514	0.383	0.264	0.167	0.100	-
FFH-HRU-4-HP	0.917	0.875	0.833	0.778	0.722	0.667	0.592	0.494	0.386	0.300	0.211
FFH-HRU-5-SF	1.014	0.972	0.917	0.875	0.819	0.758	0.672	0.586	0.447	0.314	0.208

SF = Standard Fan HP = High Pressure Fan

Model	Motor Electrical Data 230V/1Ph/50Hz				Sound Power Levels dBW									dBA @ 3m
	Speed r/min	FLC Amps	SC Amps	Power kW	Octave band mid frequencies dBW								Overall dBW	
					63	125	250	500	1K	2K	4K	8K		
FFH-HRU-1-SF	1330	1.09	2.70	0.150	71	73	72	72	74	76	72	68	82	59
FFH-HRU-2-SF	1120	3.20	8.00	0.373	71	72	70	70	73	72	68	64	80	56
FFH-HRU-2-HP	1280	4.80	12.00	0.373	70	74	70	72	73	71	70	65	80	57
FFH-HRU-3-SF	1280	4.80	12.00	0.373	70	74	70	72	73	71	70	65	80	57
FFH-HRU-3-HP	1190	6.30	15.80	0.550	71	75	72	74	75	73	71	65	82	58
FFH-HRU-4-SF	1190	6.30	15.80	0.550	71	75	72	74	75	73	71	65	82	58
FFH-HRU-4-HP	1210	5.90	14.80	0.550	76	78	75	76	77	74	73	67	84	60
FFH-HRU-5-SF	1210	5.90	14.80	0.550	76	78	75	76	77	74	73	67	84	60

SF = Standard Fan HP = High Pressure Fan

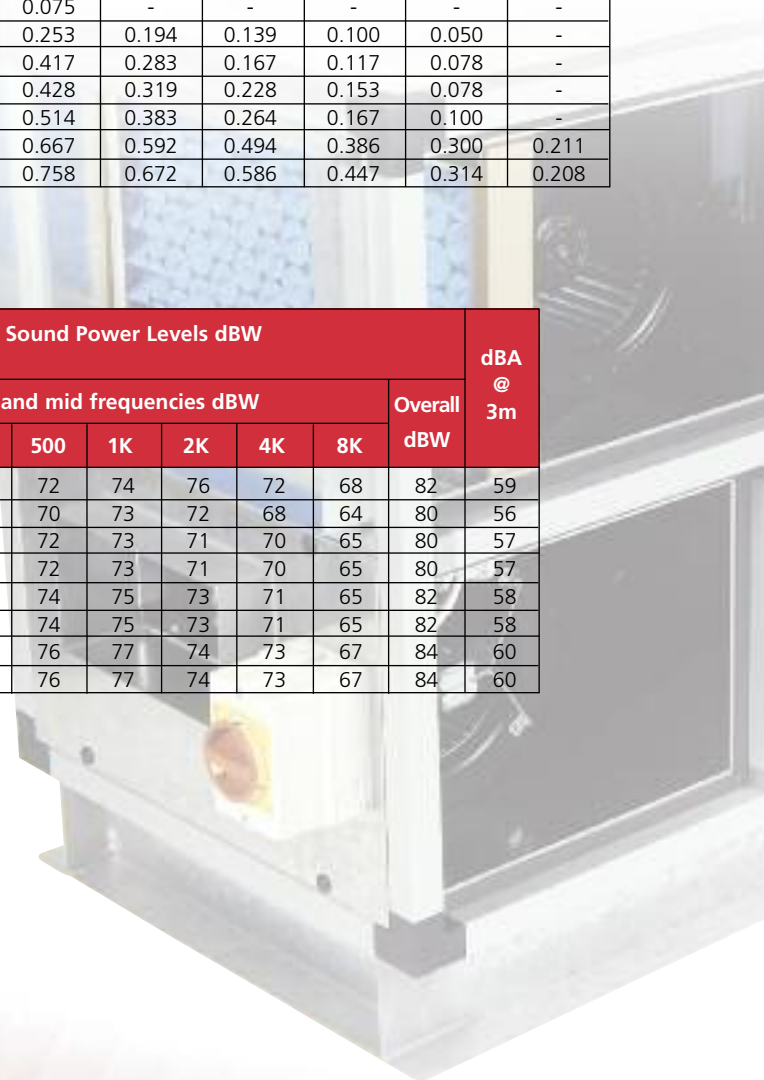

Standard Electric Heater Battery Data

You can calculate the Heater Battery Size using the following formula: $P = Q \times \rho \times \Delta t$

Where:

P = Heater Output (kW)

Q = Volume Flow Rate (m³/s)

ρ = Air Density (kg/m³)

Δt = Temperature Rise (°C)

Model	Air Volume m ³ /s	kW Rating	Single Phase Supply Steps				Three Phase Supply Steps		
			1	2	3	4	1	2	3
FFH-HRU-1-SF	All	3.00	✓	✓	✓	✓			
	All	4.50	✓	✓	✓				
	All	6.00	✓	✓	✓				
	All	7.50	✓						
FFH-HRU-2-SF FFH-HRU-2-HP	All	3.0	✓	✓					
	0.2+	4.50	✓		✓				
	0.28+	6.00	✓	✓		✓			
	0.28+	7.50	✓	✓	✓				
	0.28+	9.00	✓	✓	✓				
	0.37+	12.00	✓	✓		✓			
	0.44+	13.50					✓		✓
FFH-HRU-3-SF FFH-HRU-3-HP	All	9.00	✓	✓	✓				
	All	12.00	✓	✓		✓			
	All	18.00					✓	✓	
	0.6+	22.50					✓		
	0.66+	27.00					✓	✓	✓
FFH-HRU-4-SF FFH-HRU-4-HP	All	9.00	✓	✓	✓				
	All	12.00	✓	✓	✓	✓	✓		
	All	15.00					✓	✓	
	All	18.00					✓	✓	✓
	All	24.00					✓	✓	
	0.85+	30.00					✓	✓	
	0.98+	36.00					✓	✓	✓
FFH-HRU-5-SF	All	9.00	✓	✓					
	0.75+	12.00	✓	✓	✓	✓	✓		
	0.75+	15.00					✓	✓	
	0.75+	18.00					✓	✓	✓
	0.75+	24.00					✓	✓	
	0.8+	30.00					✓	✓	
	0.98+	36.00					✓	✓	✓

SF = Standard Fan HP = High Pressure Fan

N.B. Please enquire for duty and steps not shown.

PERFORMANCE & ELECTRICAL DATA

HEAT RECOVERY

Low Pressure Hot Water (LPHW) Data

(82°C Flow / 71°C Return)

Model	Ext Pa	Airflow m ³ /s	Airside		Waterside	
			kW	ΔT(deg C)	F/R(l/s)	Pd(kPa)
FFH-HRU-1-SF	200	0.09	5.21	48.0	0.114	5.0
	150	0.21	7.86	31.0	0.171	8.0
	100	0.26	8.64	27.5	0.188	9.0
	50	0.28	8.96	26.5	0.195	10.0
FFH-HRU-2-SF FFH-HRU-2-HP	250	0.12	-	-	-	-
	200	0.21	10.65	42.0	0.232	4.0
	150	0.28	12.17	36.0	0.265	5.0
	100	0.34	13.35	32.5	0.291	5.0
	50	0.39	14.13	30.0	0.308	5.0
FFH-HRU-3-SF FFH-HRU-3-HP	400	0.15	-	-	-	-
	300	0.42	18.77	37.0	0.409	3.0
	250	0.53	20.81	32.5	0.453	4.0
	200	0.60	22.47	31.0	0.489	4.0
	150	0.65	23.17	29.5	0.505	4.0
	100	0.70	23.68	28.0	0.516	4.0
FFH-HRU-4-SF FFH-HRU-4-HP	400	0.20	-	-	-	-
	300	0.54	22.83	35.0	0.497	3.0
	250	0.67	25.50	31.5	0.555	3.0
	200	0.76	26.63	29.0	0.580	4.0
	150	0.84	27.91	27.5	0.608	4.0
	100	0.90	28.82	26.5	0.628	4.0
	50	0.97	29.89	25.5	0.651	4.0
FFH-HRU-5-SF	600	-	-	-	-	-
	500	0.24	-	-	-	-
	400	0.60	28.62	39.5	0.623	4.0
	300	0.92	35.01	31.5	0.762	5.0
	250	0.97	35.74	30.5	0.778	5.0

SF = Standard Fan HP = High Pressure Fan

Heating duties available on application.

Heating duties for 0Pa selections also available.

Water flow rates must be maintained between min and max values shown for each unit size.

NEVADA DIMENSIONAL DATA

HEAT RECOVERY

NEVADA Heat Recovery Unit, Direct Drive Fans - Side by Side

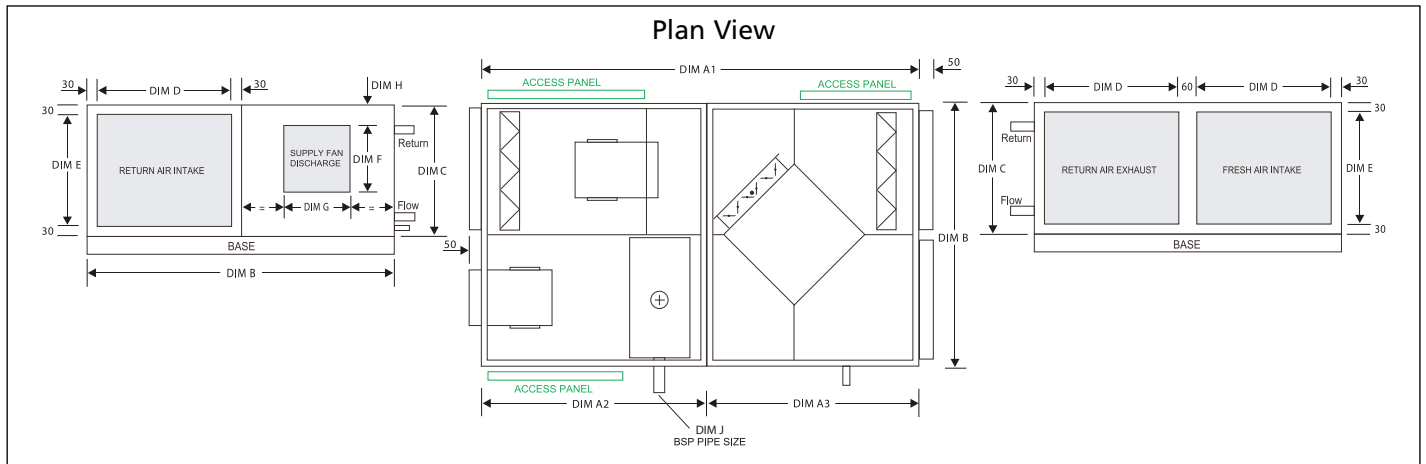

Model	A1 (1)	A1 (2)	A2	A3 (1)	A3 (2)	B	C	D	E	F	G	H	J	Weight	
														kg (1)	kg (2)
FFH-HRU-SBS-DD-1-SF	1500	1650	- (3)	- (3)	- (3)	1050	360	465	300	125	225	70	¾"	162	180
FFH-HRU-SBS-DD-2-SF	1600	1850	- (3)	- (3)	- (3)	1300	430	590	370	210	275	75	¾"	216	253
FFH-HRU-SBS-DD-2-HP	1950	1950	- (3)	- (3)	- (3)	1300	430	590	370	235	260	97	¾"	268	275
FFH-HRU-SBS-DD-3-SF	2000	2000	950	1050	1050	1300	610	590	550	260	235	125	¾"	308	314
FFH-HRU-SBS-DD-3-HP	2000	2000	950	1050	1050	1300	610	590	550	260	300	125	¾"	313	319
FFH-HRU-SBS-DD-4-SF	2000	2150	950	1050	1200	1450	610	665	550	260	300	125	1"	339	362
FFH-HRU-SBS-DD-4-HP	2050	2200	1000	1050	1200	1450	610	665	550	285	325	125	1"	350	374
FFH-HRU-SBS-DD-5-SF	2050	2200	1000	1050	1200	1590	610	735	550	285	325	125	1"	367	395

(1) Unit with recuperator but without summer bypass damper.

(2) Unit with recuperator and summer bypass damper.

(3) Unit sizes 1 and 2 are manufactured in one section.

SF = Standard Fan HP = High Pressure Fan

NEVADA Heat Recovery Unit, Direct Drive Fans - Double Decked

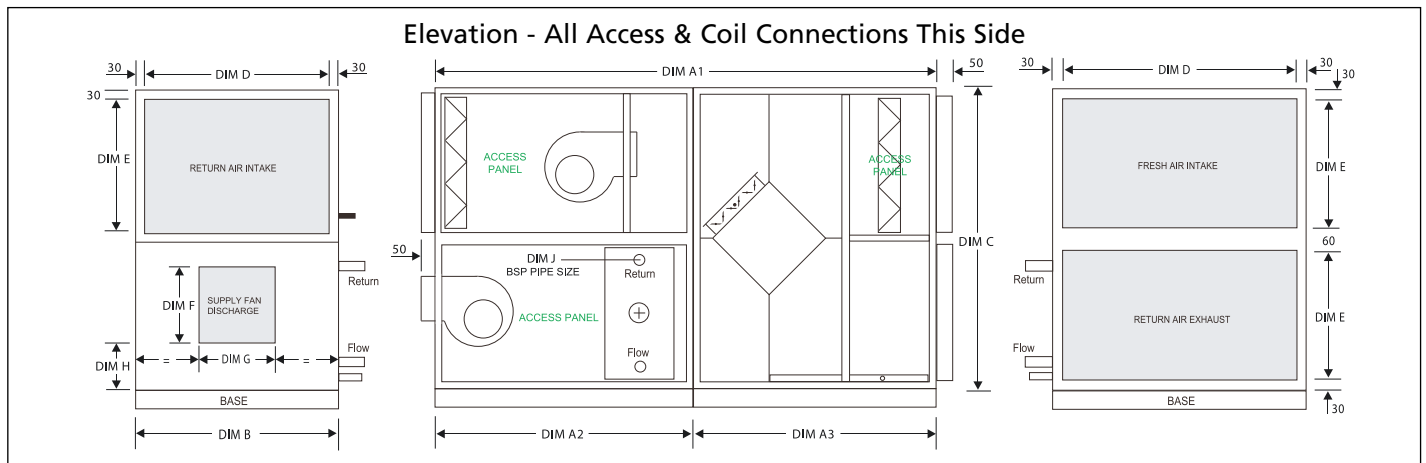

Model	A1 (1)	A1 (2)	A2	A3 (1)	A3 (2)	B	C	D	E	F	G	H	J	Weight	
														kg (1)	kg (2)
FFH-HRU-DD-DD-1-SF	1400	1600	- (3)	- (3)	- (3)	550	690	490	285	125	225	165	¾"	137	163
FFH-HRU-DD-DD-2-SF	1600	1750	- (3)	- (3)	- (3)	675	830	615	355	210	275	145	¾"	199	218
FFH-HRU-DD-DD-2-HP	1700	1800	- (3)	- (3)	- (3)	675	830	615	355	235	260	100	¾"	220	235
FFH-HRU-DD-DD-3-SF	1750	2000	950	800	1050	675	1220	615	550	260	235	225	¾"	270	307
FFH-HRU-DD-DD-3-HP	1750	2000	950	800	1050	675	1220	615	550	260	300	225	¾"	275	312
FFH-HRU-DD-DD-4-SF	1750	2000	950	800	1050	750	1220	690	550	260	300	225	1"	287	326
FFH-HRU-DD-DD-4-HP	1800	2050	1000	800	1050	750	1220	690	550	285	325	200	1"	298	337
FFH-HRU-DD-DD-5-SF	1800	2050	1000	800	1050	820	1220	760	550	285	325	200	1"	310	350

(1) Unit with recuperator but without summer bypass damper.

(2) Unit with recuperator and summer bypass damper.

(3) Unit sizes 1 and 2 are manufactured in one section.

SF = Standard Fan HP = High Pressure Fan

NEVADA

SILENCER DATA

HEAT RECOVERY

Dimensional Data

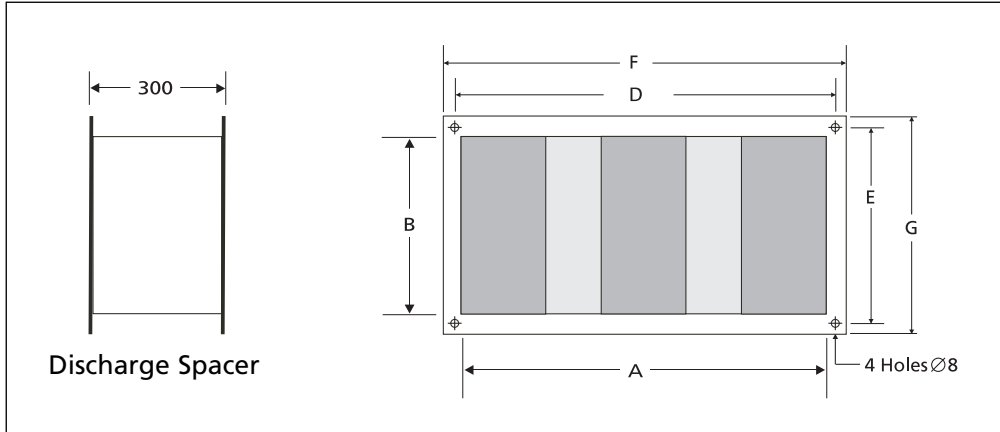

CONSTRUCTION

1.0mm Galvanised sheet steel casing. 25mm Ductmate flanges. Infill mineral wool with scrim facing and expanded mesh retainer.
Discharge Spacer for fitting between unit discharge and silencer. All dimensions as per silencer.

Model	Code	A	B	Length	D	E	F	G	Airways	Silencer Weight kg	Spacer Section kg
HRU1	NWS-0600A	450	250	600	470	270	500	300	1	13	6
	NWS-0900A			900						19	
	NWS-1200A			1200						24	
HRU2	NWS-0600B	575	320	600	595	340	625	370	2	18	7
	NWS-0900B			900						25	
	NWS-1200B			1200						33	
HRU3	NWS-0600C	575	500	600	595	520	625	550	2	24	8
	NWS-0900C			900						34	
	NWS-1200C			1200						45	
HRU4	NWS-0600D	650	500	600	670	520	700	550	2	26	9
	NWS-0900D			900						38	
	NWS-1200D			1200						49	
HRU5	NWS-0600E	720	500	600	740	520	770	550	2	27	10
	NWS-0900E			900						39	
	NWS-1200E			1200						50	

Static Insertion Loss For Silencers

Model	Octave Band Centre Frequencies Hz								
	Code	63	125	250	500	1000	2000	4000	8000
HRU1	NWS-0600A	-2	-5	-8	-12	-15	-15	-11	-11
	NWS-0900A	-3	-6	-11	-20	-25	-25	-15	-13
	NWS-1200A	-4	-7	-15	-26	-33	-33	-19	-14
HRU2	NWS-0600B	-3	-5	-7	-18	-27	-24	-18	-13
	NWS-0900B	-4	-7	-13	-26	-35	-35	-30	-20
	NWS-1200B	-5	-9	-18	-34	-45	-40	-34	-24
HRU3	NWS-0600C	-3	-5	-7	-18	-27	-24	-18	-13
	NWS-0900C	-4	-7	-13	-26	-35	-35	-30	-20
	NWS-1200C	-5	-9	-18	-34	-45	-40	-34	-24
HRU4	NWS-0600D	-3	-5	-7	-17	-23	-23	-16	-12
	NWS-0900D	-4	-7	-13	-25	-32	-32	-23	-15
	NWS-1200D	-5	-9	-19	-33	-42	-42	-30	-18
HRU5	NWS-0600E	-1	-4	-5	-12	-14	-14	-10	-6
	NWS-0900E	-2	-5	-10	-18	-23	-23	-14	-9
	NWS-1200E	-3	-6	-14	-24	-30	-30	-17	-13

Silencer Pressure Drop Performance Data

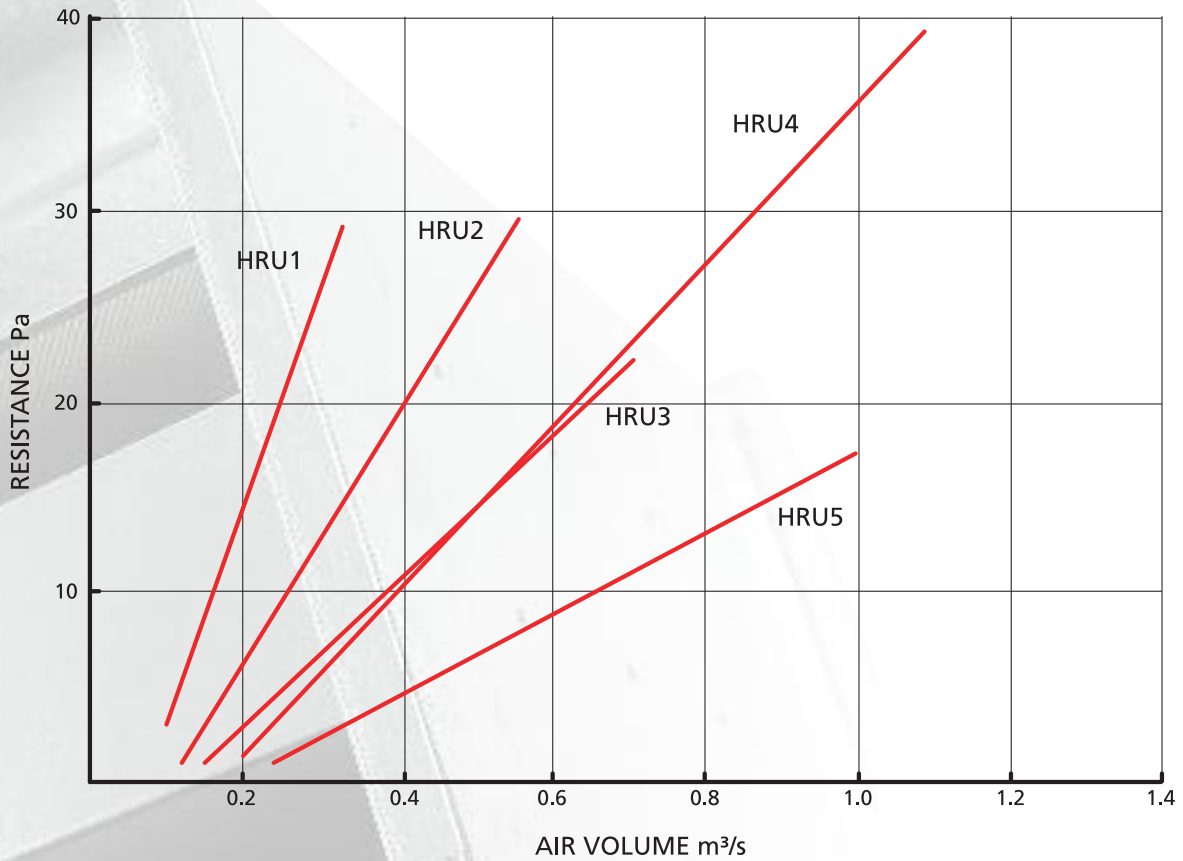

Model	Pressure Drop Pa @ Air Volume m³/s													
	0.1	0.2	0.3	0.4	0.5	0.6	0.7	0.8	0.9	1	1.1	1.2	1.3	1.4
HRU1	3	15	25	-	-	-	-	-	-	-	-	-	-	-
HRU2	-	6	13	19	25	-	-	-	-	-	-	-	-	-
HRU3	-	3	7	10	15	18	22	-	-	-	-	-	-	-
HRU4	-	2	6	10	15	18	23	27	32	36	39	-	-	-
HRU5	-	-	2	5	7	9	11	13	15	17	-	-	-	-

BESPOKE

HEAT RECOVERY



The bespoke range of heat recovery unit gives the ability to design a unit to meet particular specifications, configurations and sizes that are non standard.

Each unit is constructed from an aluminium pentapost frame and purpose built corners for style and strength, double skinned panels that provide a rigid construction for the units internal components.

Units can be supplied for internal or external mounting and a side by side or double deck arrangement to suit site requirements. All units can be supplied as Flat-Pac where site access is limited.

There are 3 types of heat recovery available; Plate to Plate recuperators, Rotary thermal wheels and Runaround Coils. Bespoke Heat Recovery units can be designed to suit most applications, with a wide variety of options available ranging from cooling and heating coils, humidifiers, dampers, Summer by pass dampers, a range of air filters, control panels and many more.

BESPOKE

HEAT RECOVERY

FEATURES & BENEFITS

Construction

Offering a flexible modular construction which provides an easier on site building option, individual sections are joined by internal bolted joints, which makes on site installation easier and faster.

The frame structure enables added versatility by providing various hanging, stacking or joining configurations.

The unit has a rigid aluminium framework, with purpose built corners for added strength.

Double skinned panels offer a smooth clean line with the outer panel available in Galvanised Sheet Steel or Plastisol coated steel.

For ease of installation and maintenance, each unit comprises slide rails offering easy access to components with minimal effort.

Performance

AHU's incorporate forward or backward curved centrifugal or plug fans with excellent performance characteristics and air volumes of up to 5.8 m³/s.

Design

Fastlane always sets out to understand the requirements of your application, offering a flexible design service to provide air handling units that match your precise requirements – A choice of construction arrangements and component sections enable Fastlane to accommodate building space restrictions, as well as those potential site handling and installation issues.

The range offers two standard arrangements; Side by Side and Double Deck. Pleated panel filters are fitted within both air streams. Condensation drain trays are fitted in all units and a wide range of heater output options are available for maximum energy efficiency. Standby fans can be incorporated into the extract side of the unit.

Units are acoustically and thermally lined with additional acoustic treatment available on request.

Flexible in design with internal or external mounting units the Bespoke range also boasts a comprehensive range of accessories including matching silencers and summer bypass dampers suitable for motorised operation.

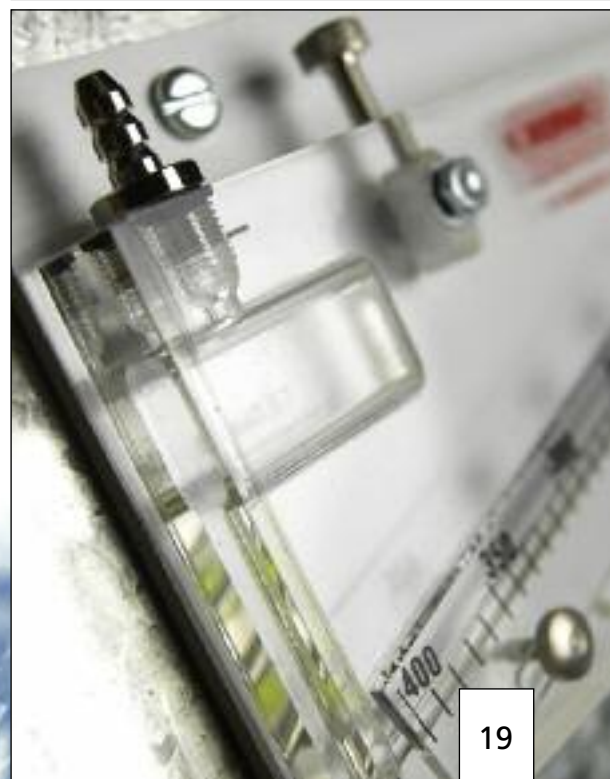

BESPOKE COMPONENT SECTION DATA

HEAT RECOVERY

Dimensional Data

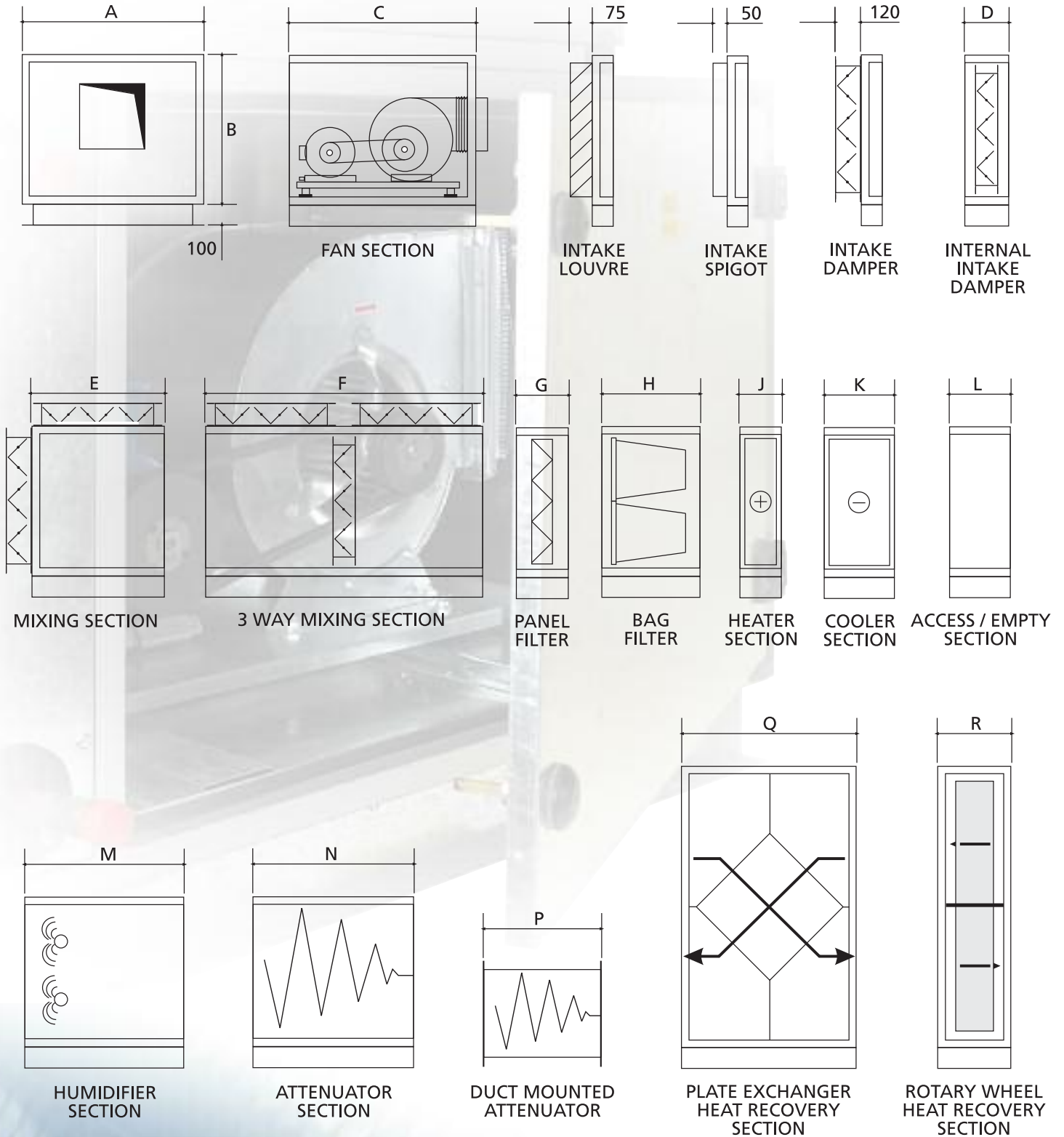

Dimensions	Unit Size											
	SA30	SA35	SA40	SA45	SA45H	SA50	SA55	SA60	SA60H	SA65	SA70	SA75H
A	660	660	660	960	660	1270	1270	1270	960	1270	1570	1270
B	460	610	710	710	960	710	870	1030	1330	1330	1330	1660
C	860	960	960	1060	1060	1060	1200	1320	1320	1380	1380	1380
D	250	250	250	250	250	250	250	300	300	300	300	300
E	310	360	460	460	560	490	590	690	890	890	890	1090
F	620	720	920	920	1120	980	1180	1380	1780	1780	1780	2180
G	300	300	300	300	300	300	300	320	320	320	320	320
H	400mm long bag filter - section length 550mm 600mm long bag filter - section length 750mm											
J	LPHW or steam heater 1 - 2 Rows - section length 270mm LPHW or steam heater 3 - 4 Rows - section length 370mm Electric heater battery - section length 370mm Indirect gas fired heater - section length 700mm to 920mm											
K	1 - 3 Rows - section length 300mm 4 - 6 Rows - section length 400mm 7 - 8 Rows - section length 450mm 9 - 10 Rows - section length 550mm } Add 200mm if moisture eliminators are required											
L	300mm - 750mm in 150mm increments											
M	1070	1070	1070	1070	1070	1070	1070	1070	1070	1070	1070	1070
N	300mm - 1800mm in 300mm increments											
P	300mm - 1800mm in 300mm increments											
Q	530	530	530	700	960	700	960	1190	1260	1260	1260	1260
R	450						470					

N.B. All Dimensions are expressed in mm.

Units of alternate cross section are available if there is difficulty in fitting the standard unit into the plant space.

Please contact Fastlane for further information.

Weights	Unit Size											
	SA30	CS35	SA40	SA45	SA45H	SA50	SA55	SA60	SA60H	SA65	SA70	SA75H
Fan	83	104	126	162	156	189	223	274	270	329	403	402
Intake Louvre	5	7	8	12	11	16	19	23	22	29	36	35
Intake Damper	8	10	12	18	16	23	29	34	33	44	54	53
Internal Intake Damper	33	39	43	60	53	75	87	102	97	123	148	145
Mixing Section 2 Dampers	42	53	64	86	88	108	139	160	174	214	249	274
Mixing Section 3 Dampers	61	76	98	128	135	162	205	245	284	341	395	442
Panel Filter	31	35	38	51	45	63	71	80	76	93	110	108
Bag Filter 400mm Long	45	51	55	71	66	87	96	106	102	123	143	141
Bag Filter 600mm Long	55	62	67	85	79	104	115	125	121	145	167	165
LPHW or Steam Heater -2 Rows	37	47	52	75	66	98	115	131	123	163	199	195
Electric Heater Battery	41	48	52	70	63	87	98	110	106	132	155	151
Indirect Gas Fired Heater	71	88	108	165	160	221	231	263	259	314	336	334
Cooling Coil - 6 Rows	62	82	93	140	124	185	224	262	245	335	416	408
Access/Empty Section 600mm	44	50	53	68	63	83	91	99	95	113	132	130
Humidifier Section	124	133	139	162	156	200	213	224	220	246	271	270
Unit Silencer 600mm	57	68	75	100	92	127	145	163	158	198	236	236
Unit Silencer 900mm	80	95	105	140	129	175	200	226	220	275	326	327
Unit Silencer 1200mm	104	122	136	179	167	224	256	290	282	351	416	419
Unit Silencer 1500mm	127	149	166	219	204	272	311	353	344	428	506	510
Unit Silencer 1800mm	150	176	196	259	241	320	366	416	406	505	596	601
Duct Silencer 600mm	13	13	17	26	26	39	53	68	68	85	101	101
Duct Silencer 900mm	19	20	26	39	39	59	80	102	102	127	152	152
Duct Silencer 1200mm	25	26	35	52	52	78	107	136	136	169	203	203
Duct Silencer 1500mm	32	33	44	65	65	98	134	170	170	212	254	254
Duct Silencer 1800mm	38	40	52	77	77	117	160	203	203	254	304	304
Plate Exchanger Heat Recovery	65	80	95	136	163	165	222	287	311	373	406	414
Rotary Wheel Heat Recovery	70	97	130	156	139	201	233	282	283	414	438	443

N.B. All weights are expressed in kg.

BESPOKE PERFORMANCE & ELECTRICAL DATA

HEAT RECOVERY

SA30

Air Vol. m ³ /s	0.2	0.25	0.3	0.4	0.5	0.55
External Resis. Pa	100	100	100	100	100	100
Fan Speed r/min	1507	1565	1647	1851	2088	2213
Motor kW	0.37	0.37	0.37	0.55	0.75	1.1
dBA@3m	66	67	69	71	77	78
Air Vol. m ³ /s	0.2	0.25	0.3	0.4	0.5	0.55
External Resis. Pa	150	150	150	150	150	150
Fan Speed r/min	1703	1743	1806	1981	2199	2316
Motor kW	0.37	0.37	0.37	0.55	0.75	1.1
dBA@3m	69	69	71	74	77	79
Air Vol. m ³ /s	0.2	0.25	0.3	0.4	0.5	0.55
External Resis. Pa	200	200	200	200	200	200
Fan Speed r/min	1882	1912	1959	2107	2306	2416
Motor kW	0.37	0.37	0.37	0.55	0.75	1.1
dBA@3m	71	71	72	75	78	79
Air Vol. m ³ /s	0.2	0.25	0.3	0.4	0.5	0.55
External Resis. Pa	250	250	250	250	250	250
Fan Speed r/min	2046	2070	2106	2229	2411	2514
Motor kW	0.37	0.37	0.37	0.55	1.1	1.1
dBA@3m	73	73	74	76	78	80
Air Vol. m ³ /s	0.2	0.25	0.3	0.4	0.5	0.55
External Resis. Pa	300	300	300	300	300	300
Fan Speed r/min	2197	2219	2247	2349	2513	2609
Motor kW	0.37	0.37	0.55	0.75	1.1	1.1
dBA@3m	74	74	75	77	79	80
Air Vol. m ³ /s	0.2	0.25	0.3	0.4	0.5	0.55
External Resis. Pa	400	400	400	400	400	400
Fan Speed r/min	2468	2492	2512	2581	2713	2796
Motor kW	0.37	0.37	0.55	0.75	1.1	1.5
dBA@3m	77	77	77	78	80	81
Air Vol. m ³ /s	0.2	0.25	0.3	0.4	0.5	0.55
External Resis. Pa	500	500	500	500	500	500
Fan Speed r/min	2708	2737	2755	2802	2906	2977
Motor kW	0.55	0.55	0.75	1.1	1.5	1.5
dBA@3m	80	79	79	80	81	82

SA 40

Air Vol. m ³ /s	0.4	0.5	0.6	0.7	0.8	0.9
External Resis. Pa	100	100	100	100	100	100
Fan Speed r/min	1092	1122	1167	1222	1287	1359
Motor kW	0.37	0.37	0.55	0.55	0.75	1.1
dBA@3m	70	71	72	74	75	77
Air Vol. m ³ /s	0.4	0.5	0.6	0.7	0.8	0.9
External Resis. Pa	150	150	150	150	150	150
Fan Speed r/min	1225	1245	1278	1321	1378	1442
Motor kW	0.37	0.55	0.55	0.75	1.1	1.1
dBA@3m	72	73	74	75	76	78
Air Vol. m ³ /s	0.4	0.5	0.6	0.7	0.8	0.9
External Resis. Pa	200	200	200	200	200	200
Fan Speed r/min	1345	1361	1384	1418	1466	1523
Motor kW	0.37	0.55	0.75	0.75	1.1	1.5
dBA@3m	74	75	75	76	77	79
Air Vol. m ³ /s	0.4	0.5	0.6	0.7	0.8	0.9
External Resis. Pa	250	250	250	250	250	250
Fan Speed r/min	1455	1469	1486	1512	1552	1602
Motor kW	0.55	0.55	0.75	1.1	1.1	1.5
dBA@3m	76	76	77	77	78	79
Air Vol. m ³ /s	0.4	0.5	0.6	0.7	0.8	0.9
External Resis. Pa	300	300	300	300	300	300
Fan Speed r/min	1557	1571	1583	1603	1636	1679
Motor kW	0.55	0.75	1.1	1.1	1.1	1.5
dBA@3m	77	78	78	78	79	80
Air Vol. m ³ /s	0.4	0.5	0.6	0.7	0.8	0.9
External Resis. Pa	400	400	400	400	400	400
Fan Speed r/min	1739	1756	1766	1776	1798	1830
Motor kW	0.75	1.1	1.1	1.1	1.5	2.2
dBA@3m	80	80	80	80	81	82
Air Vol. m ³ /s	0.4	0.5	0.6	0.7	0.8	0.9
External Resis. Pa	500	500	500	500	500	500
Fan Speed r/min	1901	1923	1933	1939	1952	1975
Motor kW	1.1	1.1	1.1	1.5	2.2	2.2
dBA@3m	82	82	82	82	83	83

SA 45

Air Vol. m ³ /s	0.6	0.8	1.0	1.2	1.4	1.6
External Resis. Pa	100	100	100	100	100	100
Fan Speed r/min	938	996	1060	1137	1222	1305
Motor kW	0.37	0.55	1.1	1.5	2.2	2.2
dBA@3m	70	72	75	78	80	83
Air Vol. m ³ /s	0.6	0.8	1.0	1.2	1.4	1.6
External Resis. Pa	150	150	150	150	150	150
Fan Speed r/min	1054	1093	1144	1212	1290	1368
Motor kW	0.55	0.75	1.1	1.5	2.2	3.0
dBA@3m	72	74	76	78	81	83
Air Vol. m ³ /s	0.6	0.8	1.0	1.2	1.4	1.6
External Resis. Pa	200	200	200	200	200	200
Fan Speed r/min	1162	1187	1225	1284	1356	1430
Motor kW	0.55	0.75	1.1	1.5	2.2	3.0
dBA@3m	74	75	77	79	81	83
Air Vol. m ³ /s	0.6	0.8	1.0	1.2	1.4	1.6
External Resis. Pa	250	250	250	250	250	250
Fan Speed r/min	1264	1277	1303	1354	1420	1489
Motor kW	0.75	1.1	1.1	1.5	2.2	3.0
dBA@3m	76	77	78	80	82	84
Air Vol. m ³ /s	0.6	0.8	1.0	1.2	1.4	1.6
External Resis. Pa	300	300	300	300	300	300
Fan Speed r/min	1358	1365	1380	1422	1482	1547
Motor kW	0.75	1.1	1.5	2.2	2.2	3.0
dBA@3m	78	78	79	81	82	84
Air Vol. m ³ /s	0.6	0.8	1.0	1.2	1.4	1.6
External Resis. Pa	400	400	400	400	400	400
Fan Speed r/min	1530	1530	1529	1554	1602	1657
Motor kW	1.1	1.5	1.5	2.2	3.0	4.0
dBA@3m	80	80	81	82	83	85
Air Vol. m ³ /s	0.6	0.8	1.0	1.2	1.4	1.6
External Resis. Pa	500	500	500	500	500	500
Fan Speed r/min	1683	1682	1671	1682	1717	1764
Motor kW	1.1	1.5	2.2	2.2	3.0	4.0
dBA@3m	82	82	83	83	84	86

SA 50

Air Vol. m ³ /s	0.8	1.0	1.2	1.5	1.8	2.1
External Resis. Pa	100	100	100	100	100	100
Fan Speed r/min	816	860	898	969	1049	1130
Motor kW	0.55	0.75	1.1	1.5	2.2	3.0
dBA@3m	70	73	75	78	81	83
Air Vol. m ³ /s	0.8	1.0	1.2	1.5	1.8	2.1
External Resis. Pa	150	150	150	150	150	150
Fan Speed r/min	916	947	975	1037	1110	1189
Motor kW	0.55	0.75	1.1	1.5	2.2	3.0
dBA@3m	72	74	76	78	81	84
Air Vol. m ³ /s	0.8	1.0	1.2	1.5	1.8	2.1
External Resis. Pa	200	200	200	200	200	200
Fan Speed r/min	1011	1030	1050	1102	1168	1242
Motor kW	0.75	1.1	1.1	2.2	3.0	4.0
dBA@3m	74	75	77	79	82	84
Air Vol. m ³ /s	0.8	1.0	1.2	1.5	1.8	2.1
External Resis. Pa	250	250	250	250	250	250
Fan Speed r/min	1100	1111	1122	1164	1225	1293
Motor kW	1.1	1.1	1.5	2.2	3.0	4.0
dBA@3m	76	77	78	80	82	85
Air Vol. m ³ /s	0.8	1.0	1.2	1.5	1.8	2.1
External Resis. Pa	300	300	300	300	300	300
Fan Speed r/min	1184	1189	1193	1226	1280	1343
Motor kW	1.1	1.1	1.5	2.2	3.0	4.0
dBA@3m	77	78	79	81	83	85
Air Vol. m ³ /s	0.8	1.0	1.2	1.5	1.8	2.1
External Resis. Pa	400	400	400	400	400	400
Fan Speed r/min	1337	1336	1329	1344	1386	1441
Motor kW	1.1	1.5	2.2	3.0	3.0	4.0
dBA@3m	80	80	81	82	84	86
Air Vol. m ³ /s	0.8	1.0	1.2	1.5	1.8	2.1
External Resis. Pa	500	500	500	500	500	500
Fan Speed r/min	1474	1472	1457	1459	1488	1534
Motor kW	1.5	2.2	2.2	3	4.0	4.0
dBA@3m	82	82	82	83	85	87

SA 55

Air Vol. m ³ /s	1.4	1.6	1.8	2.1	2.3	2.6
External Resis. Pa	100	100	100	100	100	100
Fan Speed r/min	658	688	709	743	769	806
Motor kW	1.1	1.1	1.5	2.2	2.2	3.0
dBA@3m	73	74	76	78	79	81
Air Vol. m ³ /s	1.4	1.6	1.8	2.1	2.3	2.6
External Resis. Pa	150	150	150	150	150	150
Fan Speed r/min	732	756	772	800	822	855
Motor kW	1.1	1.5	1.5	2.2	3.0	3.0
dBA@3m	75	76	77	79	80	81
Air Vol. m ³ /s	1.4	1.6	1.8	2.1	2.3	2.6
External Resis. Pa	200	200	200	200	200	200
Fan Speed r/min	803	821	832	854	873	903
Motor kW	1.5	1.5	2.2	2.2	3.0	4.0
dBA@3m	76	77	78	79	80	82
Air Vol. m ³ /s	1.4	1.6	1.8	2.1	2.3	2.6
External Resis. Pa	250	250	250	250	250	250
Fan Speed r/min	870	883	890	907	923	949
Motor kW	1.5	2.2	2.2	3.0	3.0	4.0
dBA@3m	78	78	79	80	81	83
Air Vol. m ³ /s	1.4	1.6	1.8	2.1	2.3	2.6
External Resis. Pa	300	300	300	300	300	300
Fan Speed r/min	933	943	947	959	972	994
Motor kW	1.5	2.2	2.2	3.0	3.0	4.0
dBA@3m	79	80	80	81	82	83
Air Vol. m ³ /s	1.4	1.6	1.8	2.1	2.3	2.6
External Resis. Pa	400	400	400	400	400	400
Fan Speed r/min	1051	1057	1056	1059	1067	1082
Motor kW	2.2	2.2	3.0	3.0	4.0	4.0
dBA@3m	81	82	82	83	83	84
Air Vol. m ³ /s	1.4	1.6	1.8	2.1	2.3	2.6
External Resis. Pa	500	500	500	500	500	500
Fan Speed r/min	1157	1162	1158	1155	1158	1167
Motor kW	3.0	3.0	3.0	4.0	4.0	5.5
dBA@3m	83	84	84	84	85	86

SA 60

Air Vol. m ³ /s	1.9	2.1	2.3	2.5	2.8	3.1
External Resis. Pa	100	100	100	100	100	100
Fan Speed r/min	601	629	646	664	692	719
Motor kW	1.5	1.5	2.2	2.2	3.0	4.0
dBA@3m	75	76	77	78	80	81
Air Vol. m ³ /s	1.9	2.1	2.3	2.5	2.8	3.1
External Resis. Pa	150	150	150	150	150	150
Fan Speed r/min	664	687	701	716	740	764
Motor kW	1.5	2.2	2.2	2.2	3.0	4.0
dBA@3m	76	77	78	79	81	82
Air Vol. m ³ /s	1.9	2.1	2.3	2.5	2.8	3.1
External Resis. Pa	200	200	200	200	200	200
Fan Speed r/min	724	743	754	766	786	807
Motor kW	2.2	2.2	3.0	3.0	4.0	4.0
dBA@3m	78	79	79	80	81	83
Air Vol. m ³ /s	1.9	2.1	2.3	2.5	2.8	3.1
External Resis. Pa	250	250	250	250	250	250
Fan Speed r/min	781	798	805	814	831	849
Motor kW	2.2	3.0	3.0	3.0	4.0	4.0
dBA@3m	79	80	80	81	82	83
Air Vol. m ³ /s	1.9	2.1	2.3	2.5	2.8	3.1
External Resis. Pa	300	300	300	300	300	300
Fan Speed r/min	836	850	855	862	875	891
Motor kW	2.2	3.0	3.0	3.0	4.0	4.0
dBA@3m	80	81	81	82	83	84
Air Vol. m ³ /s	1.9	2.1	2.3	2.5	2.8	3.1
External Resis. Pa	400	400	400	400	400	400
Fan Speed r/min	938	949	950	953	961	971
Motor kW	3.0	3.0	4.0	4.0	4.0	5.5
dBA@3m	83	83	83	84	84	85
Air Vol. m ³ /s	1.9	2.1	2.3	2.5	2.8	3.1
External Resis. Pa	500	500	500	500	500	500
Fan Speed r/min	1032	1040	1040	1040	1043	1049
Motor kW	4.0	4.0	4.0	4.0	5.5	5.5
dBA@3m	84	85	85	85	86	86

BESPOKE

TYPICAL ARRANGEMENTS

HEAT RECOVERY

Fastlane's choice of air handling units is based upon a series of standard components that can be combined into an array of different air handling units. The individual solution is selected from several pre-defined combinations, culminating in made to order air handling units, by assembling a special unit out of standard components.

The arrangements outlined below, provide an indication of Fastlane's 'Bespoke' capabilities.

Typical Double Deck Belt Driven Fan Unit with plate to plate recuperator, summer bypass damper, heating coil, and pleated panel filters.

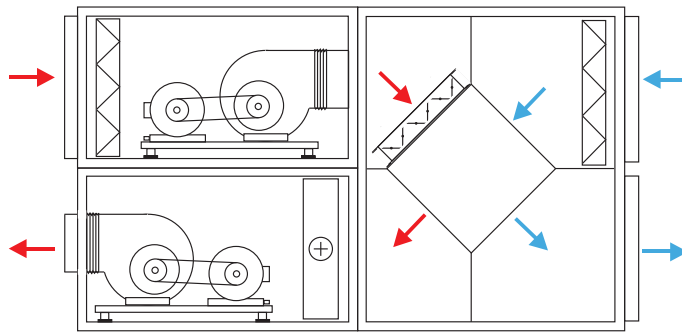

Typical Double Deck Direct Driven Fan Unit with heat recovery wheel, heating coil, cooling coil, and pleated panel filters.

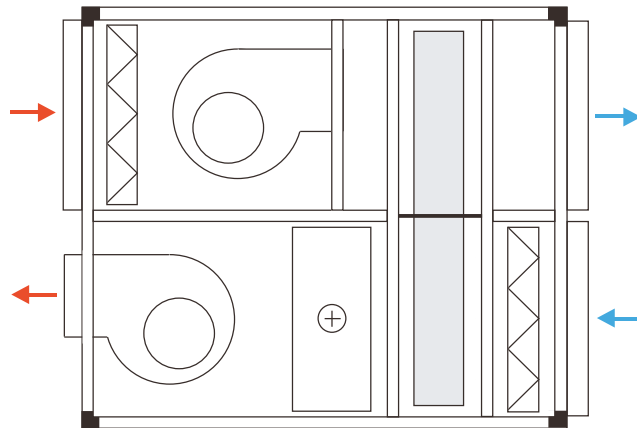

Typical Double Deck Belt Driven Fan Unit with heat recovery wheel, heating coil, cooling coil, bag and pleated panel filters.

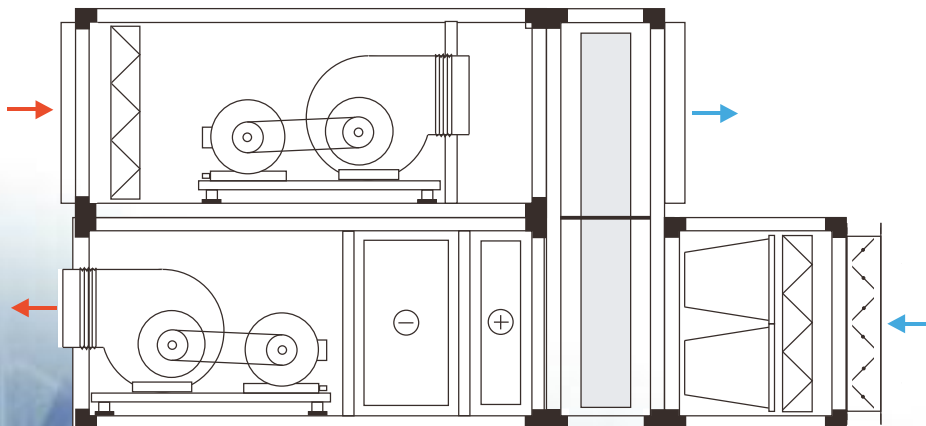



AIR HANDLING SELECTION PROGRAM

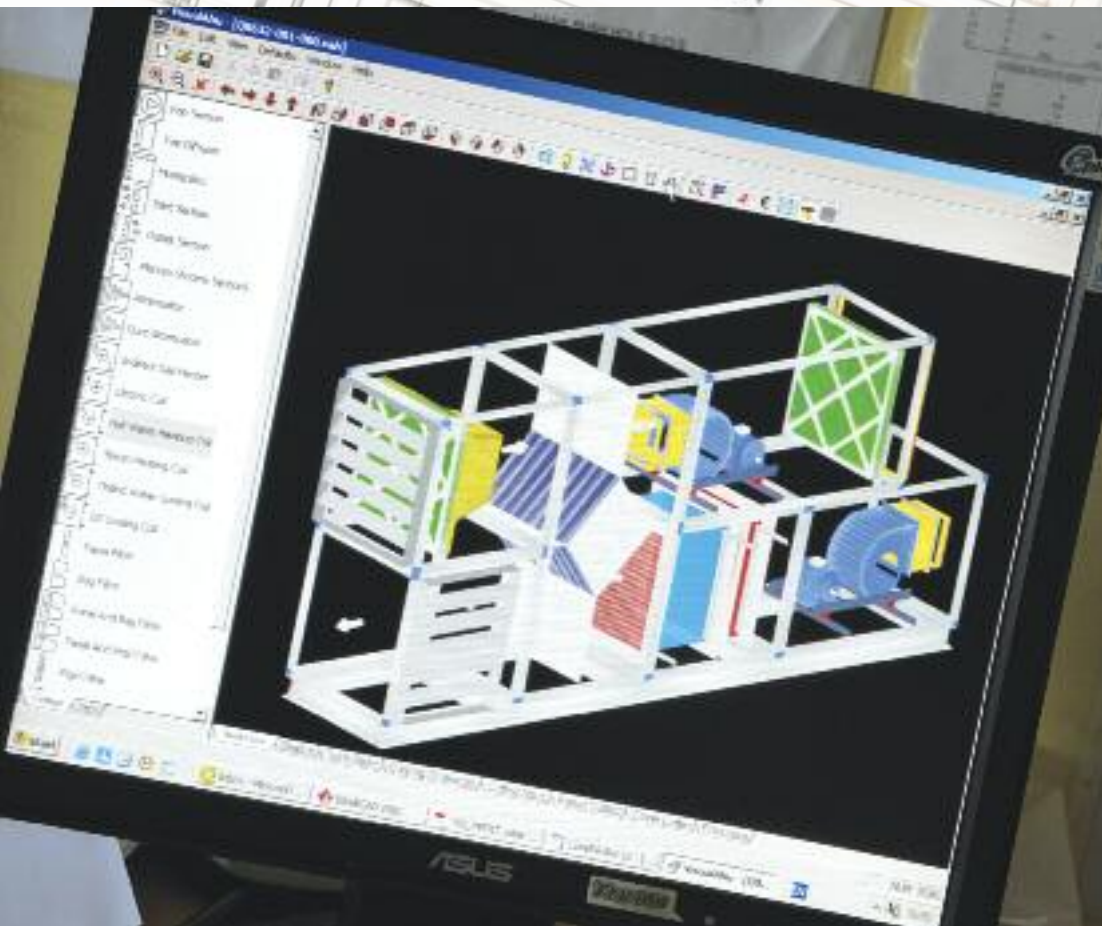

ELEVATION

Airflow	SA40
E.S.P.	0.55
Exhaust	250 Pa
Size	
Airflow	SA40
E.S.P.	0.25 m3/s
Unit Weight	250 Pa
	991.18 kg

Section A:	
1	Inlet Section (400)
2	Panel Filter (280)
Section B:	
3	Flue heat exchanger (800)
Section C:	
4	DX Cooling coil (450)
5	Water Heater (210)
6	Fan (870)
7	Plenum (330)
Section D:	
8	Attenuator (800)
9	(300)
10	Outlet Section (0)
Section E:	
11	Inlet Section (0)
12	Attenuator (800)
13	Panel Filter (280)
14	Fan (870)
Section F:	
15	Outlet Section (700)

App By	
App Date	

NOTE:
ALL DIMENSIONS IN MM UNLESS
OTHERWISE STATED
DO NOT SCALE
FINISHES AS SHOWN

Specifically designed selection software is used to facilitate the design of Fastlane's Bespoke Heat Recovery Units.

Each unit is designed and manufactured using a combination of in-house technical expertise, high quality production facilities, top quality components and an experienced workforce.

All this combined with the latest in engineering technology in the form of specifically designed software, integrating computer aided design software with 3D visualization tools and bespoke third party engineering selection programs, to deliver the complete engineered solution.

Each unit is designed to individual specifications to suit most applications and site limitations, using the computerised design software which will produce a full unit technical specification, detailed CAD drawings for client approval purposes, as well as supporting paperwork in the form of casing drawings, cutting lists for framework and panel work and buying list all ensuring that the final product is exactly as designed.

Should the specification or any of the design criteria change, the unit can be easily redesigned to incorporate the changes with the aid of the software.

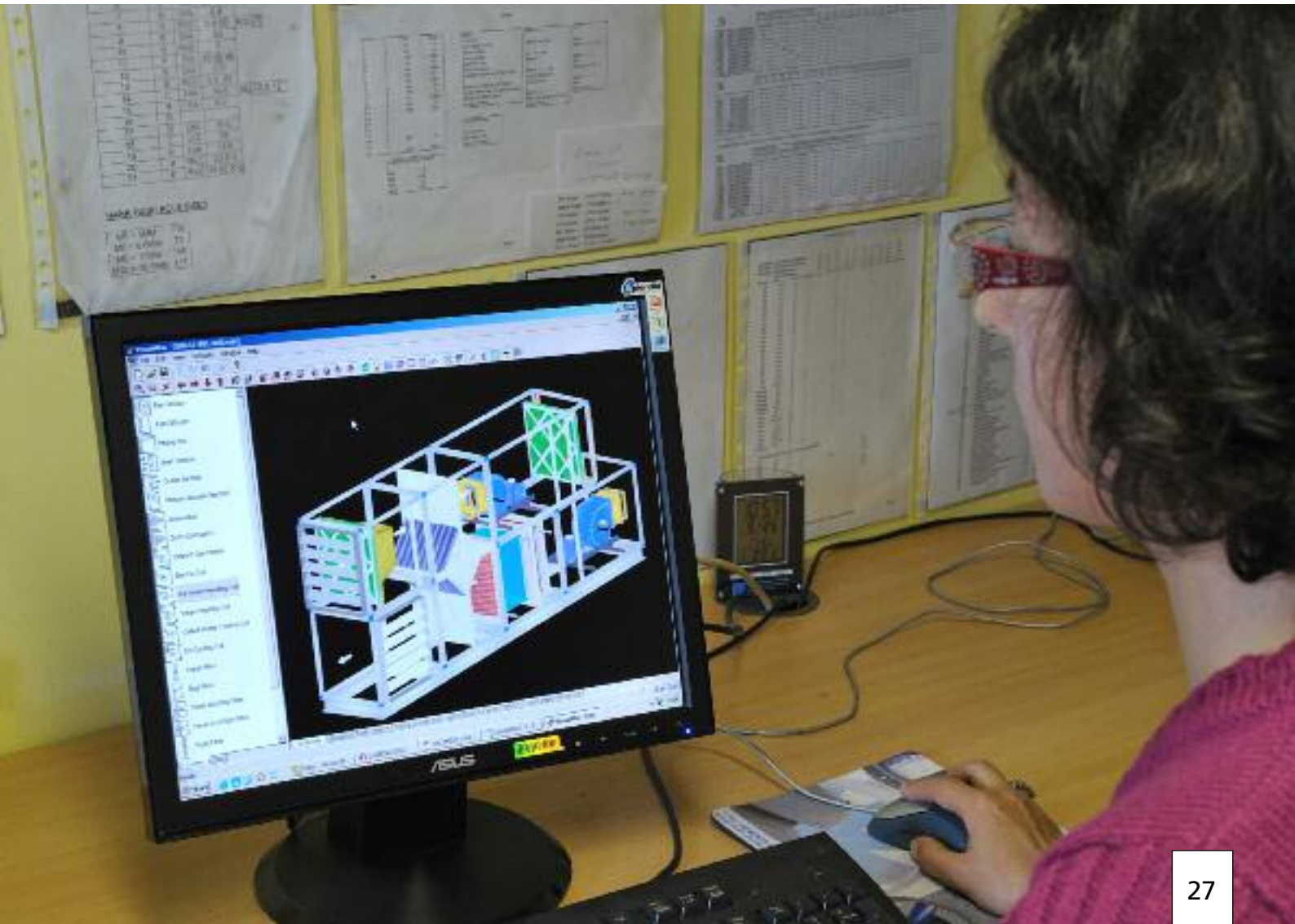
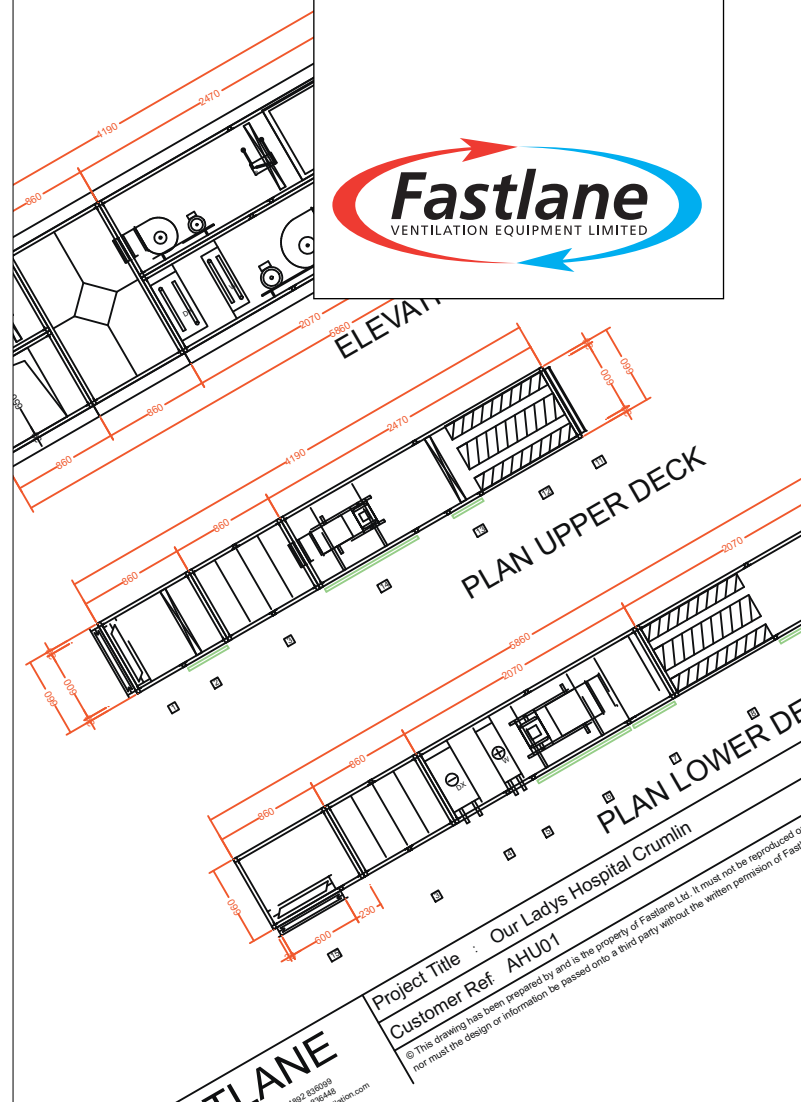
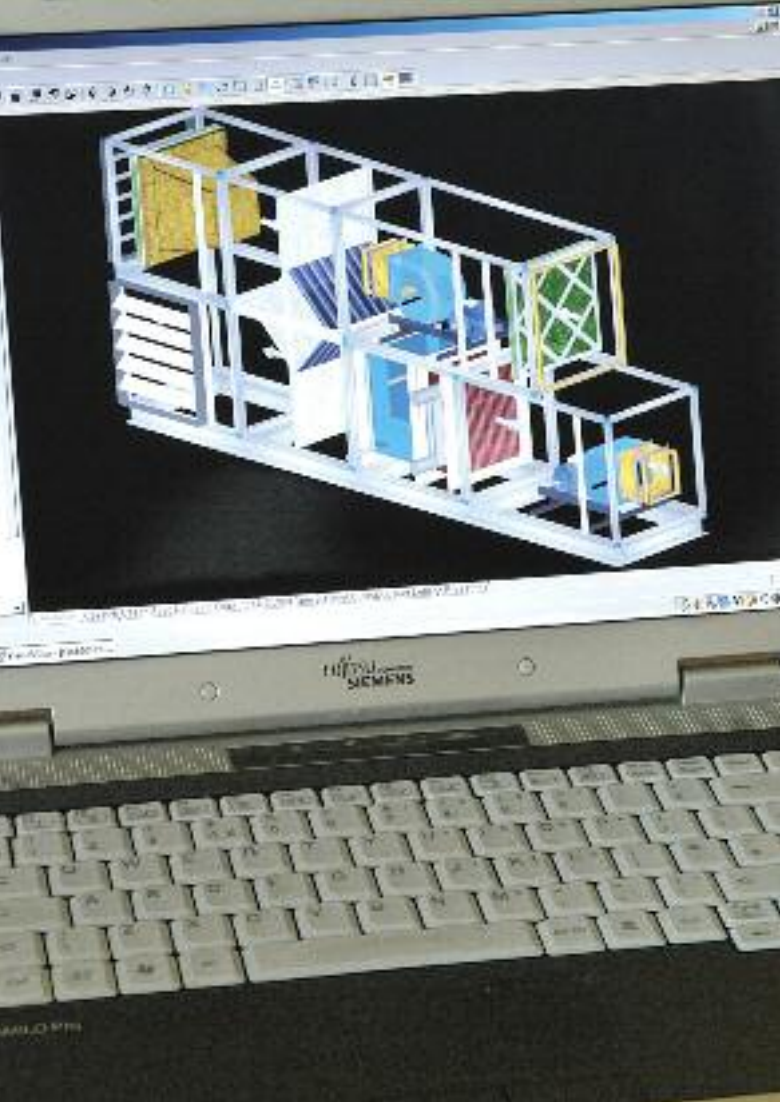

OPTIONS

Shown below are just a few of the additional components that may be included into the design of a Fastlane Bespoke Heat Recovery Air Handling Unit.

High Efficiency Bag Filters

The Filter media is of Grade F5,F6,F7 and F8 in accordance with BS EN779: 1993 with a maximum operating temperature of 100°C.

Grade F5 and F6 filters are designed to remove most mould spores, pollens and general dust from the incoming air. Grade F7 and F8 filters are designed to remove bacteria and carbon black from the incoming air.

The efficiency of these filters is imperative for the environmental conditions in which they operate, therefore they are protected with a pre-filter allowing only finer particles through, where they are trapped by the high efficiency bag filter.

Pockets are constructed from a synthetic non-woven media, a mix of coarse and fine fibres lofted into a three dimensional structure and mounted onto a flame retardant, rupture proof backing to eliminate fibre migration. Individual pockets are parallel stitched to maintain optimum media spacing, whilst the application of hot melt adhesive to each stitch hole prevents air leakage.

Pockets are supported on a copper wire frame and enclosed within a 22mm galvanised header frame.

Other frame depths are available upon request.



High Capacity Bag Filters

These filters are designed for applications with higher than normal dust loads. Filters are able to handle high air volumes combined with low pressure loss. The filter media is of Grade G4 in accordance with BS EN779: 1993 with a maximum operating temperature of 100°C.

The self supporting nature of the construction enables the bag filter to be installed with the pockets running either horizontally or vertically. Filter pockets are constructed from a lofted non-woven synthetic material with thermally bonded fibres which conform to BS 5568 Part 9 and CP413. Pockets are supported on a copper wire frame, enclosed within a 22mm galvanised steel header frame.

Other frame depths are available upon request.

Washable Filters

Constructed from a reticulated polyurethane foam pad, and enclosed within an aluminium frame with a galvanised retaining mesh fitted to the outlet face. The media is of grade G4 to BS EN779 1993 and has a maximum operating temperature of 100°C.

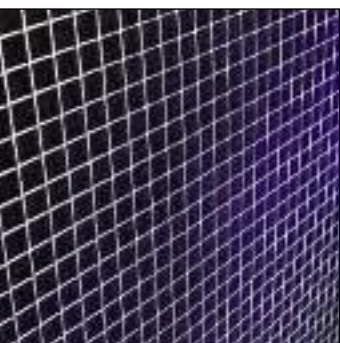
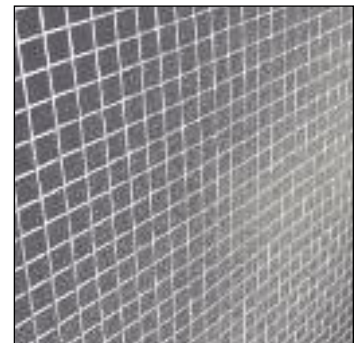

Glass Fibre Panel Filters

Glass Fibre Panel filters are constructed from a glass media pad, enclosed in a water resistant cardboard lattice frame. The large fibre surface area and graded density of the media provides high dust holding capacity and low pressure drop.

The media is of Grade G3 to BS EN779 1993 and has a maximum operating temperature of 100°C.

Rigid Bag Filters

High performance rigid pleats for use in a variety of air conditioning and general ventilation applications where large air volumes are to be handled and systems dictate high dust holding capacity, coupled with low initial resistance. These filters offer improved efficiency over traditional bag filters, out-performing bag filters in all facets of arrestance, efficiency, capacity, pressure drop and service life. Filter grades are available from F6 to F9 BS EN779 :1993. Standard lengths are 150mm and 300mm.

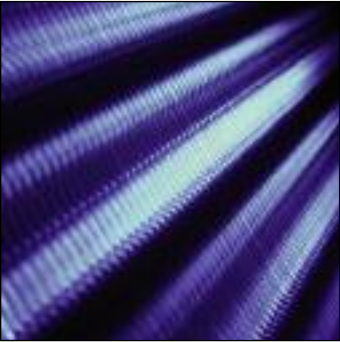

Steam Heating Coils

Coils are constructed from Seamless Drawn Copper Tube to BS 2871 mechanically expanded into aluminium fins with die formed self spacing collars.

Tubular copper headers are silver brazed into the tube ends. Flow and return connections are BSP(M).

The coil casing is formed from heavy gauge galvanised sheet steel to BS 2989 to make a rigid assembly. Tube end plates have die formed collared holes to allow expansion and contraction of the tubes without damage.

All coils are pressure tested to 17 bar with dry compressed air under water.

Chilled Water Cooling Coils

Constructed from seamless drawn copper tube to BS 2871 mechanically expanded into aluminium fins with die formed self spacing collars, the casing is formed from heavy gauge galvanised sheet to BS 2989, with BSP(M) pipe fittings on coil flow and return connections. Fitted with a galvanised sheet steel drain tray with a BSP(M) connector, stainless steel drain trays are optional. Tube end plates have die formed collared holes allowing expansion and contraction of the tubes without damage. All coils are subjected to an air under water test to 17 bar during manufacture.



DX Cooling Coils

Coils are constructed from Seamless Drawn Copper Tube to BS 2871 mechanically expanded into aluminium fins with die formed self spacing collars. Copper return bends, liquid distributor and tubular copper headers are silver brazed into the tube ends. The coil casing is formed from heavy gauge galvanised sheet steel to BS 2989.

Tube end plates have die formed collared holes allowing expansion and contraction of the tubes without damage. Drain trays are provided as standard, vee formed with an air baffle to prevent air bypass and a BSP(M) drain connection.

All coils are subjected to an air under water test to 17 bar during manufacture.

Gas Fired Heaters

These high efficiency heat exchanger units can run on either natural or liquid propane gas. Heater sections are highly flexible, accommodating either horizontal or vertical airflows with a choice of controls. The exchangers are built for a long service life, with heat exchanger tubes expanded into a collection box, eliminating welds. Tube construction is available in either stainless steel or aluminium. The range of duties extends from 11kW to 100kW output, with higher duties available where units are mounted in multiples of up to three in series and two high, side by side, enabling heat outputs up to 1200kW.



Case Furniture

The units are generally fitted with lift off access panels and handles, however a number of other options are available including hinged access doors, portholes, bulkhead lights, switches and isolators.

ACCESSORIES

Shown below are a number of accessories that may be included into the design of an Air Handling Unit to enhance the overall performance of the unit and various control options to maximise the efficient running of the unit.

Silencers

All silencer casings are made from 1.0 or 1.2mm pre-galvanised sheet steel and are finished at both ends with 25 or 35mm Ductmate flanging system. Silencers are generally sized to achieve good acoustic insertion losses whilst still maintaining moderate pressure losses. Pods consist of scrim faced non-hydroscopic, vermin proof mineral wool insulation of a minimum density of 45kg/m³ and retained by galvanised flattened expanded metal.



Speed Regulator

Speed regulators are available for all direct driven single phase air handling units and for belt driven units up to 1.1kW. Single phase controllers are available in manual or BMS options. Manual panels are for 2 or 3 wire control up to 10A Flc and offer stepless speed control, on/off rocker switch and a pre-set minimum speed facility. The BMS version is as the manual version with the exception that speed control is achieved via a 0-10 volt signal, (or from a remote 10k potentiometer), and on/off control via a set of volt free contacts. Auto transformer speed controllers are available for three phase belt driven units with up to 5.5kW motors.



Manometer

The inclined liquid column manometer has been designed to measure slight variations in pressure depression or differential pressure of air or gas. Accuracy is achieved by means of an adjustable graduated scale and a 20ml safety reservoir. The manometric liquid used is AWS 10 red oil which has a density of 0.87 at 15°C. Recommended temperature range of use is +5 to 30°C, although possible range of use is -30 to 60°C.



Electric Heater Battery Step Controllers

Controllers are mounted in either moulded ventilated, or ventilated metal epoxy coated enclosures rated to IP56.

Generally the controllers are fitted with the following features as standard;-

- Door interlocked isolator
- 1-8 automatic incremental steps of switched heating control
- Seven day digital on/off programming facility
- Automatic fan run-on timer for heater cooling on shutdown
- Separate heater, supply fan and control fusing
- Safety air-flow proving, high temperature, filter blocked interlocks
- Temperature control range of 10 to 40°C
- High temperature safety power lock-out feature
- Room or duct mounted thermostats can also be supplied.



Duct Thermostat

The Duct thermostat senses the air temperature in and out of the unit. It is used on the air intake as a frost stat, or as a supply air temperature sensor on the discharge side of the unit.

Available in a range of 1 to 4 step capillary thermostats, with an operating temperature range of -20 to +40°C, the liquid filled sensing element enables a rapid response to temperature changes. The enclosure rating is IP43.



Airflow Switch

Consists of a low torque micro switch with a maximum operating torque of 10gcm, with silver contacts and is supplied in a normally open condition. The case material is made from a phenolic resin.

Actuation is achieved via a 85 x 0.66mm diameter wire mechanically bonded to a small light gauge aluminium flag. The switch has both UL and CSA approvals.



Differential Pressure Switch

Designed and built for the measurement of non-flammable and non-aggressive gases such as air, via a silicone membrane from 20 to 2500 Pa. Switching capacity is 1.5A @ 250VAC, unit protection class is IP54 and medium ambient temperature is -20 to +85°C. Switch approval according to VDE0630 EN-1854.

Spring Anti-Vibration Mountings

Where high isolation efficiencies are required fan bases can be isolated from the structure of the air handling unit utilising spring anti vibration mountings. Depending on fan speed, motor speed and weight the deflection of the mounts can range from 15mm to 50mm and isolation efficiency can be as high as 95%. Mountings are available in several different types; open spring, open spring hangers and enclosed spring which is best suited for use in air handling units. Enclosed spring mounts have built in levelling to ensure correct loading.



Volume Control Dampers

Specifically designed to provide exacting control through air handling systems, each blade has an aerofoil section ensuring aerodynamic characteristics of quiet operation and minimal pressure drops are achieved when the damper is open. Blades incorporate an edge seal through the length of the blade preventing air bypass when the damper is closed. Blades are interlocking, with a smooth positive opposed operation, working through a nylon geared drive which can be used with manual, electric or pneumatic controls. All dampers are supplied with a single 12mm square extended drive spindle for connection to an electric or pneumatic controller, with an optional hand locking quadrant for manual control.

Plastisol Casings

Manufactured from Galvalite pre hot-dip zinc coated sheet steel with the outer surface coated with 200 microns of high performance plastisol coating, the inner surface is coated with a specially formulated two-coat protective system of corrosion-resistant primer topped with a heat cured high-performance polyester. Colour specifications available for Plastisol; Ocean Blue to BS4800 18C39 and Goose wing Grey to BS4800 10A05.

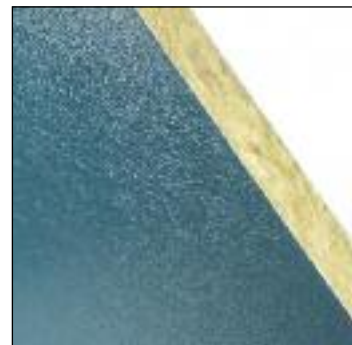

Hinged Door Panel

Fastlane AHU's have large inspection doors, making servicing and maintenance easy. The doors are secured with Allen key operated latches which means that the doors can be easily removed if required, and provided there is sufficient space available in the plant area, doors can be provided with hinges.

The doors are sealed using rubber profiles and locks can only be opened using the Allen key.

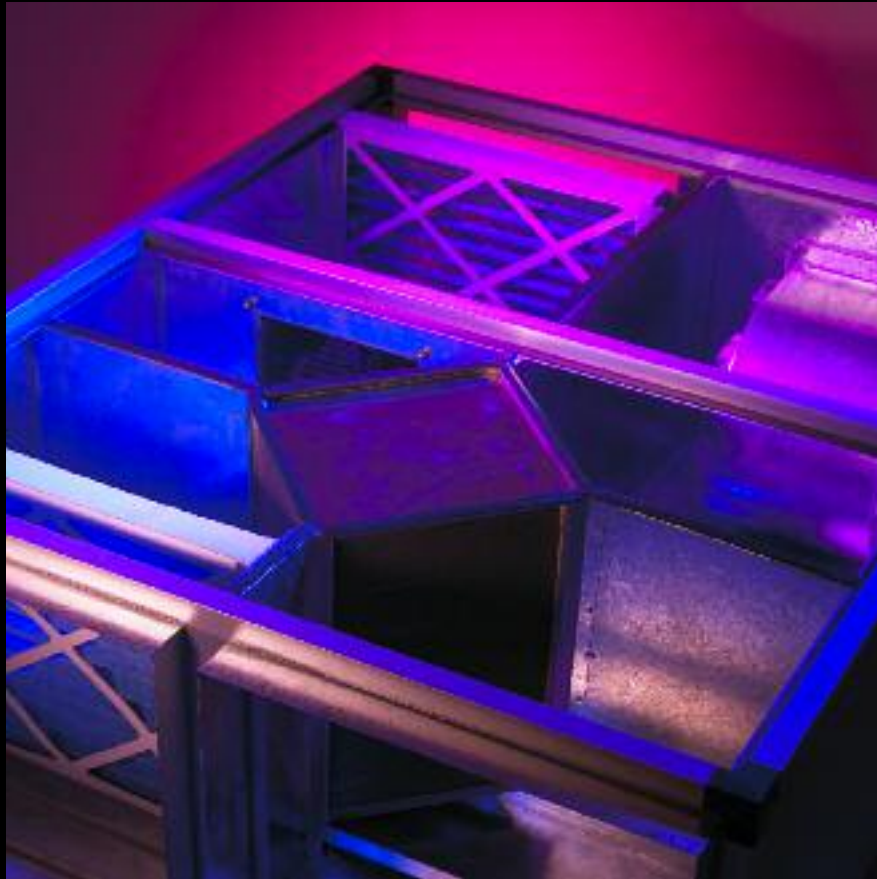

Unit 21/23, Eldon Way, Paddock Wood, Tonbridge, Kent, TN12 6BE. United Kingdom.

Tel: + 44 (0) 1892 836099 Fax: + 44 (0) 1892 836448

email: sales@fastlaneventilation.co.uk

Website: www.fastlaneventilation.com

FL/HRU/17-9-08/01